



TEXTRON AVIATION

# Pilot's Operating Handbook And FAA Approved Airplane Flight Manual **SKYHAWK** **SP**



Member of GAMA

**Model 172S**  
NAV III Avionics - GFC 700 AFCS  
Serials  
172S10468, 172S10507, 172S10640  
and 172S10656 and On

SERIAL NUMBER 172S10773

REGISTRATION NUMBER OE-DCL

This publication includes the material required to be furnished to the pilot by 14 CFR 23.

APPROVED BY

FAA APPROVED UNDER 14 CFR PART 21, SUBPART J  
Cessna Aircraft Co.  
Delegatee Order Authorization DCA-000004-CR

*Richard RLS*  
Richard RLS  
Manufacturing MGR

DATE OF APPROVAL 20 December 2007

COPYRIGHT © 2007  
CESSNA AIRCRAFT COMPANY  
WICHITA, KANSAS, USA

ORIGINAL ISSUE - 20 DECEMBER 2007  
REVISION 4 - 11 JUNE 2021

172SPHBUS-04

U.S.

**THIS MANUAL WAS PROVIDED FOR THE  
AIRPLANE IDENTIFIED ON THE TITLE  
PAGE ON \_\_\_\_\_ .  
SUBSEQUENT REVISIONS SUPPLIED BY  
TEXTRON AVIATION MUST BE  
PROPERLY INSERTED.**

---

**Textron Aviation**

**PILOT'S OPERATING HANDBOOK  
AND  
FAA APPROVED AIRPLANE FLIGHT MANUAL**

**CESSNA MODEL 172S  
NAV III AVIONICS OPTION - GFC 700 AFCS**

**SERIALS  
172S10468, 172S10507, 172S10640  
AND  
172S10656 AND ON**

**ORIGINAL ISSUE - 20 DECEMBER 2007**

**REVISION 4 - 11 JUNE 2021**

**PART NUMBER: 172SPHBUS-04**



172SPHBUS

**NOTE:** The accompanying (attached) FAA Approved Temporary Revision page(s) may or may not be applicable to your serial airplane. Please refer to the individual FAA Approved Temporary Revision page(s) to determine applicability status for your airplane.

## TEMPORARY REVISIONS

## MODEL 172S NAV III GFC 700 AFCS

U.S. Pilot's Operating Handbook and FAA Approved Airplane Flight Manual  
Model 172S Nav III - GFC 700 AFCS  
Airplanes 172S10468, 172S10507, 172S10640 and 172S10656 and On

THIS IS A LIST OF ALL CURRENT FAA APPROVED TEMPORARY REVISIONS.

The following list of temporary revisions must be incorporated into this basic U.S. Pilot's Operating Handbook and FAA Approved Airplane Flight Manual until the removal instructions have been complied with.

Insert this page opposite the Log of Effective Pages in the front of this basic U.S. Pilot's Operating Handbook and FAA Approved Airplane Flight Manual.

TEMPORARY REVISION NUMBER	PAGE NUMBER	ISSUE DATE	SERVICE BULLETIN, MODIFICATION KIT (IF APPLICABLE) OR SERIAL EFFECTIVITY
172SPHBUS-04 TR01	6-20	10/28/21	Airplanes 172S10468, 172S10507, 172S10640 and 172S10656 and On.

172SPHBUS

**NOTE:** The accompanying (attached) FAA Approved Temporary Revision page(s) may or may not be applicable to your serial airplane. Please refer to the individual FAA Approved Temporary Revision page(s) to determine applicability status for your airplane.

## TEMPORARY REVISIONS

## MODEL 172S NAV III GFC 700 AFCS

U.S. Pilot's Operating Handbook and FAA Approved Airplane Flight Manual  
Model 172S Nav III - GFC 700 AFCS  
Airplanes 172S10468, 172S10507, 172S10640 and 172S10656 and On

THIS IS A LIST OF ALL CURRENT FAA APPROVED TEMPORARY REVISIONS.

The following list of temporary revisions must be incorporated into this basic U.S. Pilot's Operating Handbook and FAA Approved Airplane Flight Manual until the removal instructions have been complied with.

Insert this page opposite the Log of Effective Pages in the front of this basic U.S. Pilot's Operating Handbook and FAA Approved Airplane Flight Manual.

TEMPORARY REVISION NUMBER	PAGE NUMBER	ISSUE DATE	SERVICE BULLETIN, MODIFICATION KIT (IF APPLICABLE) OR SERIAL EFFECTIVITY
<del>472SPHBUS-04 TR04</del>	Cancelled	Cancelled	Replaced by 172SPHBUS-04 TR05.
172SPHBUS-04 TR02	Reserved	Reserved	Reserved
172SPHBUS-04 TR03	Reserved	Reserved	Reserved
172SPHBUS-04 TR04	Reserved	Reserved	Reserved
172SPHBUS-04 TR05	6-20	1/30/24	Airplanes 172S10468, 172S10507, 172S10640 and 172S10656 and On. This TC replaces 172SPHBUS-04 TR01 in its entirety.

## CONGRATULATIONS

Congratulations on your purchase and welcome to Cessna ownership! Your Cessna has been designed and constructed to give you the most in performance, value and comfort.

This Pilot's Operating Handbook has been prepared as a guide to help you get the most utility from your airplane. It contains information about your airplane's equipment, operating procedures, performance and suggested service and care. Please study it carefully and use it as a reference.

The worldwide Textron Aviation Organization and Customer Service are prepared to serve you. The following services are offered by each Textron Aviation service facilities:

- **THE CESSNA AIRPLANE WARRANTIES**, which provide coverage for parts and labor, are upheld through Textron Aviation service facilities worldwide. Warranty provisions and other important information are contained in the Customer Care Program Handbook supplied with your airplane. The Customer Care Card assigned to you at delivery will establish your eligibility under warranty and should be presented to your local Textron Aviation service facilities at the time of warranty service.
- **FACTORY TRAINED PERSONNEL** to provide you with courteous, expert service.
- **FACTORY APPROVED SERVICE EQUIPMENT** to provide you efficient and accurate workmanship.
- **A STOCK OF GENUINE CESSNA SERVICE PARTS** are available when you need them.
- **THE LATEST AUTHORITATIVE INFORMATION FOR SERVICING CESSNA AIRPLANES.** Textron Aviation service facilities have all of the current Maintenance Manuals, Illustrated Parts Catalogs and various other support publications produced by Textron Aviation.

To locate the closest Textron Aviation service facility, visit [txtav.com/en/service-locator](http://txtav.com/en/service-locator).

We urge all Cessna owners/operators to utilize the benefits available within the Textron Aviation Organization.

**PERFORMANCE - SPECIFICATIONS****\*SPEED:**

Maximum at Sea Level . . . . . 126 KNOTS  
Cruise, 75% Power at 8500 Feet . . . . . 124 KNOTS

**CRUISE:** Recommended lean mixture with fuel allowance for engine start, taxi, takeoff, climb and 45 minutes reserve.

75% Power at 8500 Feet . . . . . Range - 518 NM  
53 Gallons Usable Fuel . . . . . Time - 4.26 HOURS  
Range, 45% Power at 10,000 Feet . . . . . Range - 638 NM  
53 Gallons Usable Fuel . . . . . Time - 6.72 HOURS

**RATE OF CLIMB AT SEA LEVEL . . . . . 730 FPM**

**SERVICE CEILING . . . . . 14,000 FEET**

**TAKEOFF PERFORMANCE:**

Ground Roll . . . . . 960 FEET  
Total Distance Over 50 Foot Obstacle . . . . . 1630 FEET

**LANDING PERFORMANCE:**

Ground Roll . . . . . 575 FEET  
Total Distance Over 50 Foot Obstacle . . . . . 1335 FEET

**STALL SPEED:**

Flaps UP, Power Idle . . . . . 53 KCAS  
Flaps FULL, Power Idle . . . . . 48 KCAS

**MAXIMUM WEIGHT:**

Ramp . . . . . 2558 POUNDS  
Takeoff . . . . . 2550 POUNDS  
Landing . . . . . 2550 POUNDS

(Continued Next Page)

**PERFORMANCE - SPECIFICATIONS** (Continued)

STANDARD EMPTY WEIGHT . . . . .	1663 POUNDS
MAXIMUM USEFUL LOAD . . . . .	895 POUNDS
BAGGAGE ALLOWANCE . . . . .	120 POUNDS
WING LOADING . . . . .	14.7 lbs/sq. ft.
POWER LOADING . . . . .	14.2 lbs/HP
FUEL CAPACITY . . . . .	56 GALLONS
OIL CAPACITY . . . . .	8 QUARTS
ENGINE: Textron Lycoming . . . . .	IO-360-L2A 180 BHP at 2700 RPM
PROPELLER:	
Fixed Pitch, Diameter . . . . .	76 INCHES

**NOTE**

\*Speed performance is shown for an airplane equipped with speed fairings which increase the speeds by approximately 2 knots. There is a corresponding difference in range, while all other performance figures are unchanged when speed fairings are installed.

The above performance figures are based on airplane weights at 2550 pounds, standard atmospheric conditions, level, hard-surfaced dry runways and no wind. They are calculated values derived from flight tests conducted by the manufacturer under carefully documented conditions and will vary with individual airplanes and numerous factors affecting flight performance.

## COVERAGE

The Pilot's Operating Handbook (POH) in the airplane at the time of delivery contains information applicable to the Model 172S Nav III airplanes by serial number and registration number shown on the Title Page. This POH is applicable to 172S airplanes, Serials 172S10468, 172S10507, 172S10640 and 172S10656 and On, equipped with the NAV III Avionics Option and Garmin GFC 700 Automatic Flight Control System (AFCS) (if installed). All information is based on data available at the time of publication.

This POH consists of nine sections that cover all operational aspects of a standard equipped airplane. Section 9 contains the supplements which provide amended operating limitations, operating procedures, performance data and other necessary information for airplanes conducting special operations for both standard and optional equipment installed in the airplane.

Supplements are individual documents, and may be issued or revised without regard to revision dates which apply to the POH itself. These supplements contain a Log of Effective Pages, which should be used to determine the status of each supplement.

## ORIGINAL ISSUE AND REVISIONS

This Pilot's Operating Handbook and FAA Approved Airplane Flight Manual is comprised of the original issue and any subsequent revisions. To make sure that information in this manual is current, the revisions must be incorporated as they are issued. As revisions are issued, they will be noted in the Log of Effective Pages.

The part number of this manual has also been designed to further aid the owner/operator in determining the revision level of any POH. Refer to the example below for a breakdown:

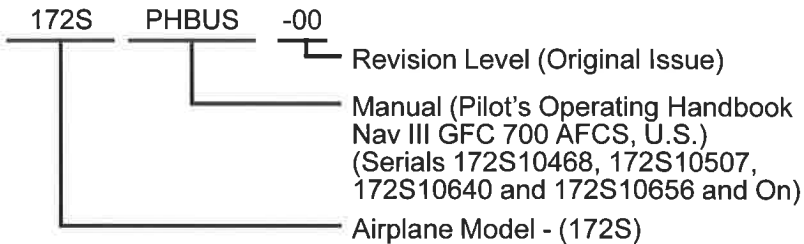

It is the responsibility of the owner to maintain this POH in a current status when it is being used for operational purposes. Owners should contact a Cessna Service Station whenever the revision status of their POH is in question.

Revisions are distributed to owners of U.S. Registered aircraft according to FAA records at the time of revision issuance, and to Internationally Registered aircraft according to Cessna Owner Advisory records at the time of issuance. Revisions should be read carefully upon receipt and incorporated in this POH.

## REVISION FILING INSTRUCTIONS

### REGULAR REVISIONS

Pages to be removed or inserted in the Pilots' Operating Handbook and FAA Approved Airplane Flight Manual are determined by the Log of Effective Pages located in this section. This log contains the page number and revision level for each page within the POH. As revisions to the POH occur, the revision level on effected pages is updated. When two pages display the same page number, the page with the latest revision level shall be inserted into the POH. The revision level on the Log Of Effective Pages shall also agree with the revision level of the page in question.

### TEMPORARY REVISIONS

Under limited circumstances, temporary revisions to the POH may be issued. These temporary revisions are to be filed in the applicable section in accordance with filing instructions appearing on the first page of the temporary revision.

Temporary Revisions will remain current until they have either been incorporated into the next POH revision or another temporary revision has been issued that supersedes that temporary revision. Each temporary revision is issued with a current List of Temporary Revisions that is to be inserted opposite the first page of the Log of Effective Pages in the front of the POH and will supersede any previously issued List of Temporary Revisions. This list is used to track the status of temporary revisions issued against this POH and is to be removed and discarded at the next revision to the POH. Removal of temporary revisions from the POH is accomplished per the removal instructions on each temporary revision.

## **IDENTIFYING REVISED MATERIAL**

A bar will extend the full length of deleted, new, or revised text added on new or previously existing pages. This bar will be located adjacent to the applicable text in the margin on the left side of the page.

A bar in the footer will indicate a revision to the header/footer, a new page, format or spelling/grammar changes and/or that information has slipped to or from that page.

A bar located adjacent to the figure number in the margin on the left side of the page will be used to indicate that the figure number only has changed.

An asterisk located at the end of a figure number will be used to indicate that an illustration has been revised or is all new material (Ex: Figure 3-4\*).

All revised pages will carry the revision number opposite the page number on the applicable page. A list of revisions is located at the beginning of the Log Of Effective Pages.

## **WARNINGS, CAUTIONS AND NOTES**

Throughout the text, warnings, cautions and notes pertaining to airplane handling and operations are utilized. These adjuncts to the text are used to highlight or emphasize important points.

### **WARNING**

**OPERATING PROCEDURES, TECHNIQUES, ETC.,  
WHICH CAN RESULT IN PERSONAL INJURY OR LOSS  
OF LIFE IF NOT CAREFULLY FOLLOWED.**

### **CAUTION**

**OPERATION PROCEDURES, TECHNIQUES, ETC.,  
WHICH CAN RESULT IN DAMAGE TO EQUIPMENT IF  
NOT CAREFULLY FOLLOWED.**

### **NOTE**

An operating procedure, technique, etc., which is considered essential to emphasize.

## LOG OF EFFECTIVE PAGES

Use this page to determine the currency and applicability of your POH.

Pages affected by the current revision are indicated by an asterisk (\*) preceding the pages listed under the Page Number column.

<u>Revision Level</u>	<u>Date of Issue</u>	<u>Revision Level</u>	<u>Date of Issue</u>
Original Issue	20 December 2007	Revision 3	7 January 2021
Revision 1	12 January 2009	Revision 4	11 June 2021
Revision 2	18 November 2010		

---

<b>Page Number</b>	<b>Page Status</b>	<b>Revision Number</b>
* Title	Revised	4
Assignment Record	Revised	3
* i/ii	Revised	4
iii	Revised	3
iv	Original	0
v thru vi	Revised	3
vii thru x	Original	0
* xi thru xiv	Revised	4
xv/xvi thru xvii/xviii	Added	2
1-1/1-2	Original	0
1-3	Revised	2
1-4	Original	0
1-5	Revised	3
1-6 thru 1-30	Original	0
2-1/2-2	Revised	3
2-3 thru 2-5	Original	0
2-6	Revised	1
* 2-7	Revised	4
2-8 thru 2-10	Original	0
2-11	Revised	2

(Continued Next Page)

**LOG OF EFFECTIVE PAGES** (Continued)

<b>Page Number</b>	<b>Page Status</b>	<b>Revision Number</b>
2-12 thru 2-13	Original	0
* 2-14 thru 2-17	Revised	4
2-18	Original	0
2-19	Revised	3
2-20	Revised	2
2-21 thru 2-22	Revised	3
2-23 thru 2-28	Original	0
3-1	Original	0
* 3-2	Revised	4
3-3/3-4 thru 3-16	Original	0
3-17	Revised	3
3-18	Original	0
3-19	Revised	3
3-20	Original	0
* 3-21	Revised	4
3-22	Original	0
* 3-23	Revised	4
3-24	Revised	3
3-25 thru 3-28	Original	0
* 3-29 thru 3-31	Revised	4
3-32 thru 3-33	Original	0
3-34 thru 3-35	Revised	2
3-36 thru 3-39/3-40	Original	0
4-1 thru 4-4	Revised	2
* 4-5	Original	4
4-6	Revised	3
4-7 thru 4-10	Revised	2
4-11	Original	0
4-12	Revised	1
4-13 thru 4-14	Revised	2
* 4-15 thru 4-16	Revised	4
4-17	Revised	3
4-18 thru 4-19	Original	0

(Continued Next Page)

## 172SPHBUS

**NOTE:** The accompanying (attached) FAA Approved Temporary Revision page(s) may or may not be applicable to your serial airplane. Please refer to the individual FAA Approved Temporary Revision page(s) to determine applicability status for your airplane.

## TEMPORARY REVISIONS

## MODEL 172S NAV III GFC 700 AFCS

U.S. Pilot's Operating Handbook and FAA Approved Airplane Flight Manual  
Model 172S Nav III - GFC 700 AFCS  
Airplanes 172S10468, 172S10507, 172S10640 and 172S10656 and On

THIS IS A LIST OF ALL CURRENT FAA APPROVED TEMPORARY REVISIONS.

The following list of temporary revisions must be incorporated into this basic U.S. Pilot's Operating Handbook and FAA Approved Airplane Flight Manual until the removal instructions have been complied with.

Insert this page opposite the Log of Effective Pages in the front of this basic U.S. Pilot's Operating Handbook and FAA Approved Airplane Flight Manual.

TEMPORARY REVISION NUMBER	PAGE NUMBER	ISSUE DATE	SERVICE BULLETIN, MODIFICATION KIT (IF APPLICABLE) OR SERIAL EFFECTIVITY
172SPHBUS-04 TR01	6-20	10/28/21	Airplanes 172S10468, 172S10507, 172S10640 and 172S10656 and On.

**LOG OF EFFECTIVE PAGES** (Continued)

<b>Page Number</b>	<b>Page Status</b>	<b>Revision Number</b>
4-20 thru 4-22	Revised	3
4-23 thru 4-26	Original	0
4-27	Revised	1
4-28 thru 4-29	Revised	2
4-30	Revised	3
4-31 thru 4-32	Revised	2
4-33 thru 4-40	Revised	1
4-41 thru 4-43	Original	0
4-44	Revised	2
4-45 thru 4-48	Original	0
5-1/5-2 thru 5-10	Original	0
5-11	Revised	1
5-12	Original	0
5-13 thru 5-14	Revised	2
5-15 thru 5-24	Original	0
6-1/6-2 thru 6-17/6-18	Original	0
6-19	Revised	2
6-20 thru 6-21	Revised	1
* 6-22 thru 6-23	Revised	4
6-24	Revised	1
* 7-1	Revised	4
7-2	Original	0
* 7-3/7-4	Revised	4
7-5 thru 7-6	Original	0
7-7 thru 7-10	Revised	2
7-11	Original	0
* 7-12	Revised	4
7-13	Revised	3
* 7-14 thru 7-24	Revised	4
7-25	Original	0
7-26	Revised	1

(Continued Next Page)

**LOG OF EFFECTIVE PAGES** (Continued)

Page Number	Page Status	Revision Number
7-27 thru 7-28	Original	0
* 7-29 thru 7-30	Revised	4
7-31 thru 7-37	Original	0
7-38	Revised	2
7-39 thru 7-48	Original	0
* 7-49	Revised	4
7-50	Original	0
* 7-51	Revised	4
7-52	Original	0
7-53 thru 7-54	Revised	2
7-55 thru 7-57	Original	0
7-58 thru 7-60	Revised	2
* 7-61 thru 7-62	Revised	4
7-63 thru 7-64	Original	0
* 7-65 thru 7-66	Revised	4
7-67 thru 7-68	Original	0
7-69 thru 7-71	Revised	3
7-72 thru 7-76	Original	0
7-77	Revised	3
7-78 thru 7-80	Original	0
8-1 thru 8-2	Original	0
8-3 thru 8-5	Revised	3
8-6 thru 8-25/8-26	Original	0
9-1/9-2	Original	0

APPROVED BY



Stephen Gielisch, Lead ODA Administrator  
 Textron Aviation Inc.  
 Organization Delegation Authorization ODA-100129-CE  
 FAA Approved Under 14 CFR Part 183 Subpart D

DATE OF APPROVAL

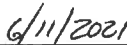

## SERVICE BULLETIN CONFIGURATION LIST

The following is a list of Service Bulletins that are applicable to the operation of the airplane, and have been incorporated into this manual. This list contains only those Service Bulletins that are currently active.

<u>Number</u>	<u>Title</u>	<u>Airplane Serial Effectivity</u>	<u>Revision Incorporated</u>	<u>Incorporated in Airplane</u>
SB08-34-03	Forward Looking Terrain Avoidance (FLTA) Alert Over The Open Ocean/Sea	172S10468, 172S10507, 172S10640 and 172S10656 thru 172S10775	1	



## TABLE OF CONTENTS

	SECTION
GENERAL .....	1
LIMITATIONS .....	2
EMERGENCY PROCEDURES .....	3
NORMAL PROCEDURES .....	4
PERFORMANCE .....	5
WEIGHT AND BALANCE/EQUIPMENT LIST .....	6
AIRPLANE AND SYSTEM DESCRIPTION .....	7
HANDLING, SERVICE AND MAINTENANCE .....	8
SUPPLEMENTS .....	9



## GENERAL

### TABLE OF CONTENTS

	Page
Three View - Normal Ground Attitude . . . . .	1-3
Introduction . . . . .	1-5
Descriptive Data . . . . .	1-5
Engine . . . . .	1-5
Propeller . . . . .	1-5
Fuel . . . . .	1-6
Fuel Capacity . . . . .	1-6
Oil . . . . .	1-7
Oil Specification . . . . .	1-7
Oil Capacity . . . . .	1-7
Maximum Certificated Weights . . . . .	1-8
Weight In Baggage Compartment - Normal Category . . . . .	1-8
Weight In Baggage Compartment - Utility Category . . . . .	1-8
Standard Airplane Weights . . . . .	1-9
Cabin And Entry Dimensions . . . . .	1-9
Baggage Space And Entry Dimensions . . . . .	1-9
Specific Loadings . . . . .	1-9
Symbols, Abbreviations And Terminology . . . . .	1-10
General Airspeed Terminology And Symbols . . . . .	1-10
Meteorological Terminology . . . . .	1-11
Engine Power Terminology . . . . .	1-11
Airplane Performance And Flight Planning Terminology . . . . .	1-13
Weight And Balance Terminology . . . . .	1-14
Metric/Imperial/U.S. Conversion Charts . . . . .	1-16
Weight Conversions . . . . .	1-17
Length Conversions . . . . .	1-19
Distance Conversions . . . . .	1-23
Volume Conversions . . . . .	1-24
Temperature Conversions . . . . .	1-27
Pressure Conversion . . . . .	1-28
Volume To Weight Conversion . . . . .	1-29
Quick Conversions . . . . .	1-30



### THREE VIEW - NORMAL GROUND ATTITUDE

B3079

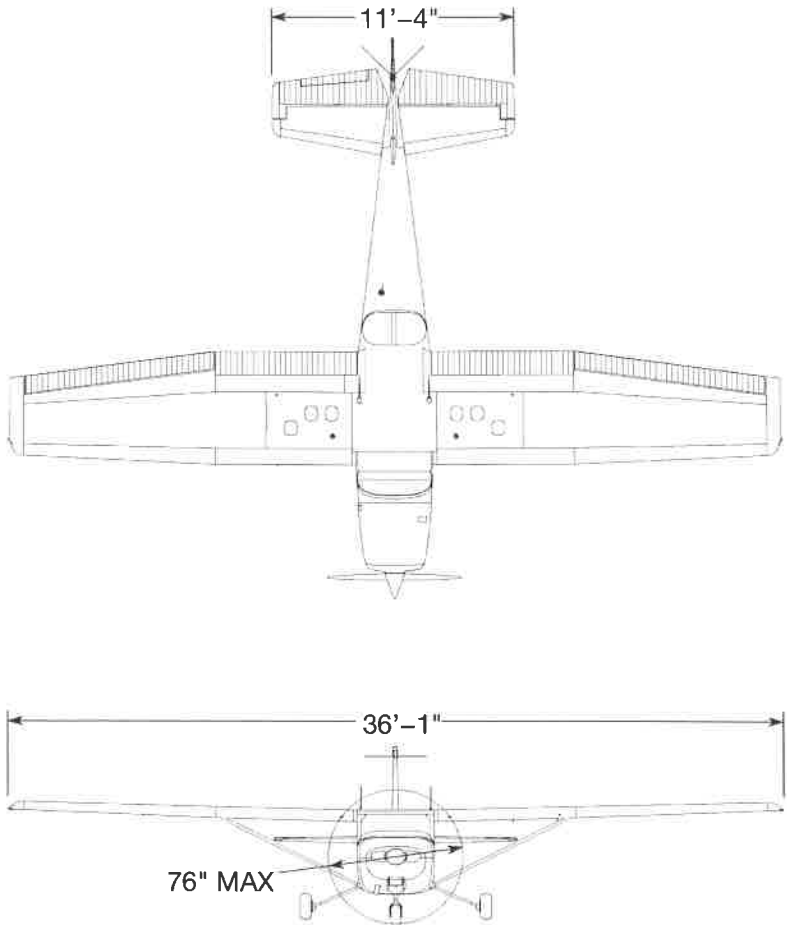

0510T1002  
0510T1003

Figure 1-1\* (Sheet 1 of 2)

## THREE VIEW - NORMAL GROUND ATTITUDE

B3080

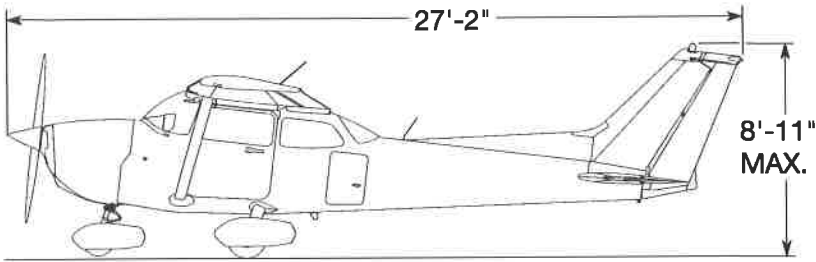

0510T1008

### NOTE

- Wing span shown with standard strobe lights installed.
- Wheel base length is 65.0 inches.
- Propeller ground clearance is 11.25 inches.
- Wing area is 174.0 square feet.
- Minimum turning radius (\*pivot point to outboard wing tip) is 27.0 feet, 5.50 inches.
- Normal ground attitude is shown with nose strut showing approximately 2 inches of strut, and wings level.

Figure 1-1 (Sheet 2)

## **INTRODUCTION**

This POH contains 9 sections, and includes the material required to be furnished to the pilot by 14 CFR 23. It also contains supplemental data supplied by the manufacturer.

Section 1 provides basic data and information of general interest. It also contains definitions or explanations of symbols, abbreviations, and terminology commonly used.

## **DESCRIPTIVE DATA**

### **ENGINE**

Number of Engines: 1

Engine Manufacturer: Textron Lycoming

Engine Model Number: IO-360-L2A

Engine Type: Normally aspirated, direct drive, air-cooled, horizontally opposed, fuel injected, four cylinder engine with 360.0 cu. in. displacement.

Horsepower Rating and Engine Speed: 180 rated BHP at 2700 RPM

### **PROPELLER**

Propeller Manufacturer: McCauley Propeller Systems

Propeller Model Number: 1A170E/JHA7660

Number of Blades: 2

Propeller Diameter: 76 inches

Propeller Type: Fixed pitch

(Continued Next Page)

## DESCRIPTIVE DATA (Continued)

### FUEL

#### WARNING

**USE OF UNAPPROVED FUELS MAY RESULT IN DAMAGE TO THE ENGINE AND FUEL SYSTEM COMPONENTS, RESULTING IN POSSIBLE ENGINE FAILURE.**

Approved Fuel Grades (and Colors):

- 100LL Grade Aviation Fuel (Blue)
- 100 Grade Aviation Fuel (Green)

#### NOTE

Isopropyl alcohol or Diethylene Glycol Monomethyl Ether (DiEGME) may be added to the fuel supply. Additive concentrations shall not exceed 1% for isopropyl alcohol or 0.10% to 0.15% for DiEGME. Refer to Section 8 for additional information.

### FUEL CAPACITY

Total Capacity . . . . .	.56.0 U.S. GALLONS
Total Usable . . . . .	.53.0 U.S. GALLONS
Total Capacity Each Tank . . . . .	.28.0 U.S. GALLONS
Total Usable Each Tank . . . . .	.26.5 U.S. GALLONS

#### NOTE

To ensure maximum fuel capacity and minimize crossfeeding when refueling, always park the airplane in a wings level, normal ground attitude and place the fuel selector in the LEFT or RIGHT position. Refer to Figure 1-1 for normal ground attitude dimensions.

(Continued Next Page)

**DESCRIPTIVE DATA** (Continued)

**OIL**

**OIL SPECIFICATION**

MIL-L-6082 or SAE J1966 Aviation Grade Straight Mineral Oil: Used when the airplane was delivered from the factory and should be used to replenish the supply during the first 25 hours. This oil should be drained and the filter changed after the first 25 hours of operation. Refill the engine with MIL-L-6082 or SAE J1966 Aviation Grade Straight Mineral Oil and continue to use until a total of 50 hours has accumulated or oil consumption has stabilized.

MIL-L-22851 or SAE J1899 Aviation Grade Ashless Dispersant Oil: Oil conforming to Textron Lycoming Service Instruction No 1014, and all revisions and supplements thereto, **must be used** after first 50 hours or oil consumption has stabilized.

Recommended viscosity for temperature range:

Temperature	MIL-L-6082 or SAE J1966 Straight Mineral Oil SAE Grade	MIL-L-22851 or SAE J1899 Ashless Dispersant Oil SAE Grade
Above 27°C (80°F)	60	60
Above 16°C (60°F)	50	40 or 50
-1°C (30°F) to 32°C (90°F)	40	40
-18°C (0°F) to 21°C (70°F)	30	30, 40 or 20W-40
Below -12°C (10°F)	20	30 or 20W-30
-18°C (0°F) to 32°C (90°F)	20W-50	20W-50 or 15W-50
All Temperatures	---	15W-50 or 20W-50

**NOTE**

When operating temperatures overlap, use the lighter grade of oil.

**OIL CAPACITY**

Sump . . . . . 8 U.S. QUARTS  
 Total . . . . . 9 U.S. QUARTS

(Continued Next Page)

## DESCRIPTIVE DATA (Continued)

### MAXIMUM CERTIFICATED WEIGHTS

Ramp Weight:

Normal Category . . . . . 2558 POUNDS

Utility Category . . . . . 2208 POUNDS

Takeoff Weight:

Normal Category . . . . . 2550 POUNDS

Utility Category . . . . . 2200 POUNDS

Landing Weight:

Normal Category . . . . . 2550 POUNDS

Utility Category . . . . . 2200 POUNDS

### WEIGHT IN BAGGAGE COMPARTMENT, NORMAL CATEGORY

Baggage Area A (Station 82 to 108) . . . . . 120 POUNDS

. . . . . Refer to note below.

Baggage Area B (Station 108 to 142) . . . . . 50 POUNDS

. . . . . Refer to note below.

#### NOTE

The maximum allowable combined weight capacity for baggage in areas A and B is 120 pounds.

### WEIGHT IN BAGGAGE COMPARTMENT, UTILITY CATEGORY

In this category, the rear seat must not be occupied and the baggage compartment must be empty.

(Continued Next Page)

## **DESCRIPTIVE DATA** (Continued)

### **STANDARD AIRPLANE WEIGHTS**

Standard Empty Weight . . . . .	1663 POUNDS
Maximum Useful Load, Normal Category . . . . .	895 POUNDS
Maximum Useful Load, Utility Category. . . . .	545 POUNDS

### **CABIN AND ENTRY DIMENSIONS**

Detailed dimensions of the cabin interior and entry door openings are illustrated in Section 6.

### **BAGGAGE SPACE AND ENTRY DIMENSIONS**

Dimensions of the baggage area and baggage door opening are illustrated in detail in Section 6.

### **SPECIFIC LOADINGS**

Wing Loading . . . . .	14.7 lbs/sq. ft.
Power Loading . . . . .	14.2 lbs/HP

## SYMBOLS, ABBREVIATIONS AND TERMINOLOGY

### GENERAL AIRSPEED TERMINOLOGY AND SYMBOLS

**KCAS**     **Knots Calibrated Airspeed** is indicated airspeed corrected for position and instrument error and expressed in knots. Knots calibrated airspeed is equal to KTAS in standard atmosphere at sea level.

**KIAS**     **Knots Indicated Airspeed** is the speed shown on the airspeed indicator and expressed in knots.

**KTAS**     **Knots True Airspeed** is the airspeed expressed in knots relative to undisturbed air which is KCAS corrected for altitude and temperature.

**V<sub>A</sub>**     **Maneuvering Speed** is the maximum speed at which full or abrupt control movements may be used without overstressing the airframe.

**V<sub>FE</sub>**     **Maximum Flap Extended Speed** is the highest speed permissible with wing flaps in a prescribed extended position.

**V<sub>NO</sub>**     **Maximum Structural Cruising Speed** is the speed that should not be exceeded except in smooth air, then only with caution.

**V<sub>NE</sub>**     **Never Exceed Speed** is the speed limit that may not be exceeded at any time.

**V<sub>S</sub>**     **Stalling Speed or the minimum steady flight speed** is the minimum speed at which the airplane is controllable.

**V<sub>SO</sub>**     **Stalling Speed or the minimum steady flight speed** is the minimum speed at which the airplane is controllable in the landing configuration at the most forward center of gravity.

**V<sub>x</sub>**     **Best Angle of Climb Speed** is the speed which results in the greatest gain of altitude in a given horizontal distance.

**V<sub>Y</sub>**     **Best Rate of Climb Speed** is the speed which results in the greatest gain in altitude in a given time.

(Continued Next Page)

## **SYMBOLS, ABBREVIATIONS AND TERMINOLOGY**

(Continued)

### **METEOROLOGICAL TERMINOLOGY**

**OAT**                    **Outside Air Temperature** is the free air static temperature. It may be expressed in either degrees Celsius or degrees Fahrenheit.

**Standard Temperature**            **Standard Temperature** is 15°C at sea level pressure altitude and decreases by 2°C for each 1000 feet of altitude.

**Pressure Altitude**                **Pressure Altitude** is the altitude read from an altimeter when the altimeter's barometric scale has been set to 29.92 inches of mercury (1013 mb).

### **ENGINE POWER TERMINOLOGY**

**BHP**                    **Brake Horsepower** is the power developed by the engine.

**RPM**                    **Revolutions Per Minute** is engine speed.

**Static RPM**                **Static RPM** is engine speed attained during a full throttle engine runup when the airplane is on the ground and stationary.

**Lean Mixture**                Decreased proportion of fuel in the fuel-air mixture supplied to the engine. As air density decreases, the amount of fuel required by the engine decreases for a given throttle setting. Adjusting the fuel-air mixture to provide a smaller portion of fuel is known as "leaning" the mixture.

(Continued Next Page)

## **SYMBOLS, ABBREVIATIONS AND TERMINOLOGY**

(Continued)

### **ENGINE POWER TERMINOLOGY (Continued)**

Rich Mixture	Increased proportion of fuel in the fuel-air mixture supplied to the engine. As air density increases, the amount of fuel required by the engine increases for a given throttle setting. Adjusting the fuel-air mixture to provide a greater portion of fuel is known as "richening" the mixture.
Full Rich	Mixture control full forward (pushed in, full control travel, toward the panel).
Idle Cutoff	Mixture control full aft (pulled out, full control travel, away from the panel).
Full Throttle	Throttle full forward (pushed in, full control travel, toward the panel). Also known as "full open" throttle.
Closed Throttle	Throttle full aft (pulled out, full control travel, away from the panel). Also known as the throttle "idle" position.

(Continued Next Page)

## **SYMBOLS, ABBREVIATIONS AND TERMINOLOGY**

(Continued)

### **AIRPLANE PERFORMANCE AND FLIGHT PLANNING TERMINOLOGY**

Demonstrated  
Crosswind  
Velocity

**Demonstrated Crosswind Velocity** is the velocity of the crosswind component for which adequate control of the airplane during takeoff and landing was actually demonstrated during certification tests. The value shown is not considered to be limiting.

Usable  
Fuel

**Usable Fuel** is the fuel available for flight planning.

Unusable  
Fuel

**Unusable Fuel** is the quantity of fuel that can not be safely used in flight.

GPH

**Gallons Per Hour** is the amount of fuel consumed per hour.

NMPG

**Nautical Miles Per Gallon** is the distance which can be expected per gallon of fuel consumed at a specific engine power setting and/or flight configuration.

g

**g** is acceleration due to gravity.

Course  
Datum

**Course Datum** is the compass reference used by the autopilot, along with course deviation, to provide lateral control when tracking a navigation signal.

(Continued Next Page)

## SYMBOLS, ABBREVIATIONS AND TERMINOLOGY

(Continued)

### WEIGHT AND BALANCE TERMINOLOGY

Reference Datum	<b>Reference Datum</b> is an imaginary vertical plane from which all horizontal distances are measured for balance purposes.
Station	<b>Station</b> is a location along the airplane fuselage given in terms of the distance from the reference datum.
Arm	<b>Arm</b> is the horizontal distance from the reference datum to the center of gravity (C.G.) of an item.
Moment	<b>Moment</b> is the product of the weight of an item multiplied by its arm. (Moment divided by the constant 1000 is used in this POH to simplify balance calculations by reducing the number of digits.)
Center of Gravity (C.G.)	<b>Center of Gravity</b> is the point at which an airplane, or equipment, would balance if suspended. Its distance from the reference datum is found by dividing the total moment by the total weight of the airplane.
C.G. Arm	<b>Center of Gravity Arm</b> is the arm obtained by adding the airplane's individual moments and dividing the sum by the total weight.
C.G. Limits	<b>Center of Gravity Limits</b> are the extreme center of gravity locations within which the airplane must be operated at a given weight.
Standard Empty Weight	<b>Standard Empty Weight</b> is the weight of a standard airplane, including unusable fuel, full operating fluids and full engine oil.

(Continued Next Page)

## **SYMBOLS, ABBREVIATIONS AND TERMINOLOGY** (Continued)

### **WEIGHT AND BALANCE TERMINOLOGY** (Continued)

Basic Empty  
Weight

**Basic Empty Weight** is the standard empty weight plus the weight of optional equipment.

Useful Load

**Useful Load** is the difference between ramp weight and the basic empty weight.

MAC

**MAC (Mean Aerodynamic Chord)** is a chord of an imaginary rectangular airfoil having the same pitching moments throughout the flight range as that of the actual wing.

Maximum  
Ramp  
Weight

**Maximum Ramp Weight** is the maximum weight approved for ground maneuver, and includes the weight of fuel used for start, taxi and runup.

Maximum  
Takeoff  
Weight

**Maximum Takeoff Weight** is the maximum weight approved for the start of the takeoff roll.

Maximum  
Landing  
Weight

**Maximum Landing Weight** is the maximum weight approved for the landing touchdown.

Tare

**Tare** is the weight of chocks, blocks, stands, etc. used when weighing an airplane, and is included in the scale readings. Tare is deducted from the scale reading to obtain the actual (net) airplane weight.

## **METRIC/IMPERIAL/U.S. CONVERSION CHARTS**

The following charts have been provided to help international operators convert U.S. measurement supplied with the Pilot's Operating Handbook into metric and imperial measurements.

The standard followed for measurement units shown is the National Institute of Standards Technology (NIST), Publication 811, "Guide for the Use of the International System of Units (SI)."

Please refer to the following pages for these charts.

## WEIGHT CONVERSIONS

B5719

(Kilograms x 2.205 = Pounds)    (Pounds x .454 = Kilograms)

### Kilograms into Pounds Kilogrammes en Livres

kg	0	1	2	3	4	5	6	7	8	9
	lb.	lb.	lb.	lb.	lb.	lb.	lb.	lb.	lb.	lb.
0	---	2.205	4.409	6.614	8.819	11.023	13.228	15.432	17.637	19.842
10	22.046	24.251	26.456	28.660	30.865	33.069	35.274	37.479	39.683	41.888
20	44.093	46.297	48.502	50.706	52.911	55.116	57.320	59.525	61.729	63.934
30	66.139	68.343	70.548	72.753	74.957	77.162	79.366	81.571	83.776	85.980
40	88.185	90.390	92.594	94.799	97.003	99.208	101.41	103.62	105.82	108.03
50	110.23	112.44	114.64	116.85	119.05	121.25	123.46	125.66	127.87	130.07
60	132.28	134.48	136.69	138.89	141.10	143.30	145.51	147.71	149.91	152.12
70	154.32	156.53	158.73	160.94	163.14	165.35	167.55	169.76	171.96	174.17
80	176.37	178.57	180.78	182.98	185.19	187.39	189.60	191.80	194.01	196.21
90	198.42	200.62	202.83	205.03	207.24	209.44	211.64	213.85	216.05	218.26
100	220.46	222.67	224.87	227.08	229.28	231.49	233.69	235.90	238.10	240.30

### Pounds into Kilograms Livres en Kilogrammes

lb.	0	1	2	3	4	5	6	7	8	9
	kg	kg	kg	kg	kg	kg	kg	kg	kg	kg
0	---	0.454	0.907	1.361	1.814	2.268	2.722	3.175	3.629	4.082
10	4.536	4.990	5.443	5.897	6.350	6.804	7.257	7.711	8.165	8.618
20	9.072	9.525	9.979	10.433	10.886	11.340	11.793	12.247	12.701	13.154
30	13.608	14.061	14.515	14.969	15.422	15.876	16.329	16.783	17.237	17.690
40	18.144	18.597	19.051	19.504	19.958	20.412	20.865	21.319	21.772	22.226
50	22.680	23.133	23.587	24.040	24.494	24.948	25.401	25.855	26.303	26.762
60	27.216	27.669	28.123	28.576	29.030	29.484	29.937	30.391	30.844	31.298
70	31.752	32.205	32.659	33.112	33.566	34.019	34.473	34.927	35.380	35.834
80	36.287	36.741	37.195	37.648	38.102	38.555	39.009	39.463	39.916	40.370
90	40.823	41.277	41.731	42.184	42.638	43.091	43.545	43.999	44.452	44.906
100	45.359	45.813	46.266	46.720	47.174	47.627	48.081	48.534	48.988	49.442

Figure 1-2 (Sheet 1 of 2)

## WEIGHT CONVERSIONS

B3081

(Kilograms x 2.205 = Pounds)

(Pounds x .454 = Kilograms)

POUNDS

KILOGRAMS

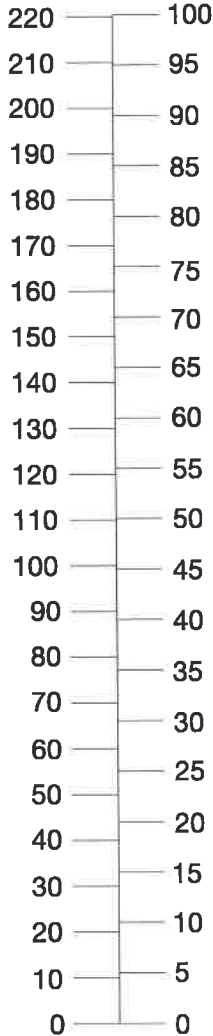

Units x 10, 100, etc.

0585T1027

Figure 1-2 (Sheet 2)

## LENGTH CONVERSIONS

B5720

(Meters x 3.281 = Feet)    (Feet x .305 = Meters)

### Meters into Feet Metres en Pieds

m	0	1	2	3	4	5	6	7	8	9
	feet	feet	feet	feet	feet	feet	feet	feet	feet	feet
0	---	3.281	6.562	9.842	13.123	16.404	19.685	22.956	26.247	29.528
10	32.808	36.089	39.370	42.651	45.932	49.212	52.493	55.774	59.055	62.336
20	65.617	68.897	72.178	75.459	78.740	82.021	85.302	88.582	91.863	95.144
30	98.425	101.71	104.99	108.27	111.55	114.83	118.11	121.39	124.67	127.95
40	131.23	134.51	137.79	141.08	144.36	147.64	150.92	154.20	157.48	160.76
50	164.04	167.32	170.60	173.86	177.16	180.45	183.73	187.01	190.29	193.57
60	195.85	200.13	203.41	206.69	209.97	213.25	216.53	219.82	223.10	226.38
70	229.66	232.94	236.22	239.50	242.78	246.06	249.34	252.62	255.90	259.19
80	262.47	265.75	269.03	272.31	275.59	278.87	282.15	285.43	288.71	291.58
90	295.27	298.56	301.84	305.12	308.40	311.68	314.96	318.24	321.52	324.80
100	328.08	331.36	334.64	337.93	341.21	344.49	347.77	351.05	354.33	357.61

### Feet into Meters Pieds en Metres

ft	0	1	2	3	4	5	6	7	8	9
	m	m	m	m	m	m	m	m	m	m
0	---	0.305	0.610	0.914	1.219	1.524	1.829	2.134	2.438	2.743
10	3.048	3.353	3.658	3.962	4.267	4.572	4.877	5.182	5.486	5.791
20	6.096	6.401	6.706	7.010	7.315	7.620	7.925	8.230	8.534	8.839
30	9.144	9.449	9.754	10.058	10.363	10.668	10.973	11.278	11.582	11.887
40	12.192	12.497	12.802	13.106	13.411	13.716	14.021	14.326	14.630	14.935
50	15.240	15.545	15.850	16.154	16.459	16.754	17.069	17.374	17.678	17.983
60	18.288	18.593	18.898	19.202	19.507	19.812	20.117	20.422	20.726	21.031
70	21.336	21.641	21.946	22.250	22.555	22.860	23.165	23.470	23.774	24.079
80	24.384	24.689	24.994	25.298	25.603	25.908	26.213	26.518	26.822	27.127
90	27.432	27.737	28.042	28.346	28.651	28.956	29.261	29.566	29.870	30.175
100	30.480	30.785	31.090	31.394	31.699	32.004	32.309	32.614	32.918	33.223

Figure 1-3 (Sheet 1 of 4)

## LENGTH CONVERSIONS

B3082

(Meters x 3.281 = Feet)

(Feet x .305 = Meters)

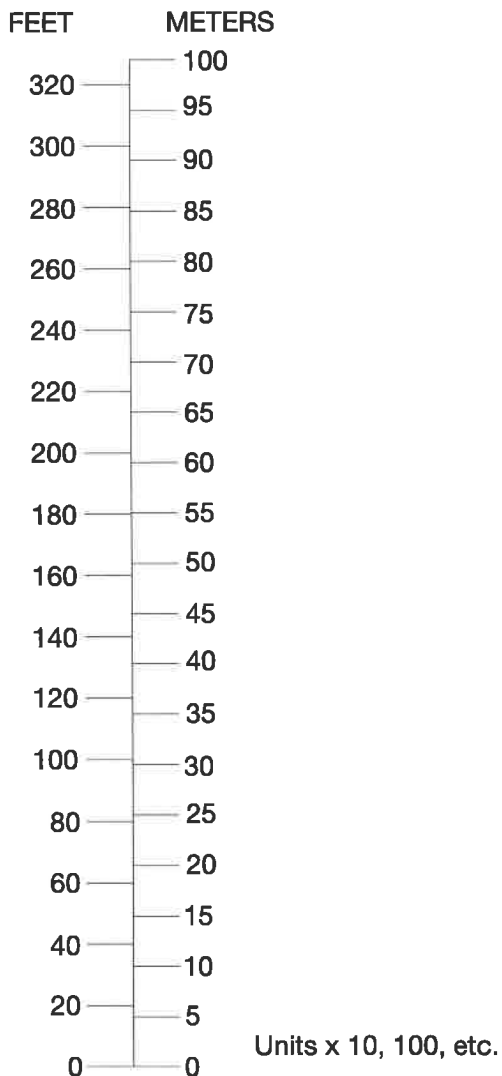

0585T1027

Figure 1-3 (Sheet 2)

## LENGTH CONVERSIONS

B5721

(Centimeters x .394 = Inches)    (Inches x 2.54 = Centimeters)

### Centimeters into Inches Centimetres en Pouces

cm	0	1	2	3	4	5	6	7	8	9
	in.	in.	in.	in.	in.	in.	in.	in.	in.	in.
0	---	0.394	0.787	1.181	1.575	1.969	2.362	2.756	3.150	3.543
10	3.937	4.331	4.724	5.118	5.512	5.906	6.299	6.693	7.087	7.480
20	7.874	8.268	8.661	9.055	9.449	9.843	10.236	10.630	11.024	11.417
30	11.811	12.205	12.598	12.992	13.386	13.780	14.173	14.567	14.961	15.354
40	15.748	16.142	16.535	16.929	17.323	17.717	18.110	18.504	18.898	19.291
50	19.685	20.079	20.472	20.866	21.260	21.654	22.047	22.441	22.835	23.228
60	23.622	24.016	24.409	24.803	25.197	25.591	25.984	26.378	26.772	27.164
70	27.559	27.953	28.346	28.740	29.134	29.528	29.921	30.315	30.709	31.102
80	31.496	31.890	32.283	32.677	33.071	33.465	33.858	34.252	34.646	35.039
90	35.433	35.827	36.220	36.614	37.008	37.402	37.795	38.189	38.583	38.976
100	39.370	39.764	40.157	40.551	40.945	41.339	41.732	42.126	42.520	42.913

### Inches into Centimeters Pouces en Centimetres

in.	0	1	2	3	4	5	6	7	8	9
	cm	cm	cm	cm	cm	cm	cm	cm	cm	cm
0	---	2.54	5.08	7.62	10.16	12.70	15.24	17.78	20.32	22.86
10	25.40	27.94	30.48	33.02	35.56	38.10	40.64	43.18	45.72	48.26
20	50.80	53.34	55.88	58.42	60.96	63.50	66.04	68.58	71.12	73.66
30	76.20	78.74	81.28	83.82	86.36	88.90	91.44	93.98	96.52	99.06
40	101.60	104.14	106.68	109.22	111.76	114.30	116.84	119.38	121.92	124.46
50	127.00	129.54	132.08	134.62	137.16	139.70	142.24	144.78	147.32	149.86
60	152.40	154.94	157.48	160.02	162.56	165.10	167.64	170.18	172.72	175.26
70	177.80	180.34	182.88	185.42	187.96	190.50	193.04	195.58	198.12	200.66
80	203.20	205.74	208.28	210.82	213.36	215.90	218.44	220.98	223.52	226.06
90	228.60	231.14	233.68	236.22	238.76	241.30	243.84	246.38	248.92	251.46
100	254.00	256.54	259.08	261.62	264.16	266.70	269.24	271.78	274.32	276.86

Figure 1-3 (Sheet 3)

# LENGTH CONVERSIONS

B3083  
(Centimeters x .394 = Inches)      (Inches x 2.54 = Centimeters)

INCHES

CENTIMETERS

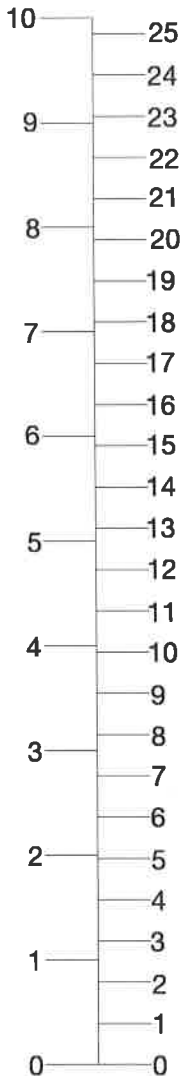

Units x 10, 100, etc.

0585T1028

Figure 1-3 (Sheet 4)

## DISTANCE CONVERSIONS

B3084

(Statute Miles x 1.609 = Kilometers)      (Kilometers x .622 = Statute Miles)  
 (Statute Miles x .869 = Nautical Miles)      (Nautical Miles x 1.15 = Statute Miles)  
 (Nautical Miles x 1.852 = Kilometers)      (Kilometers x .54 = Nautical Miles)

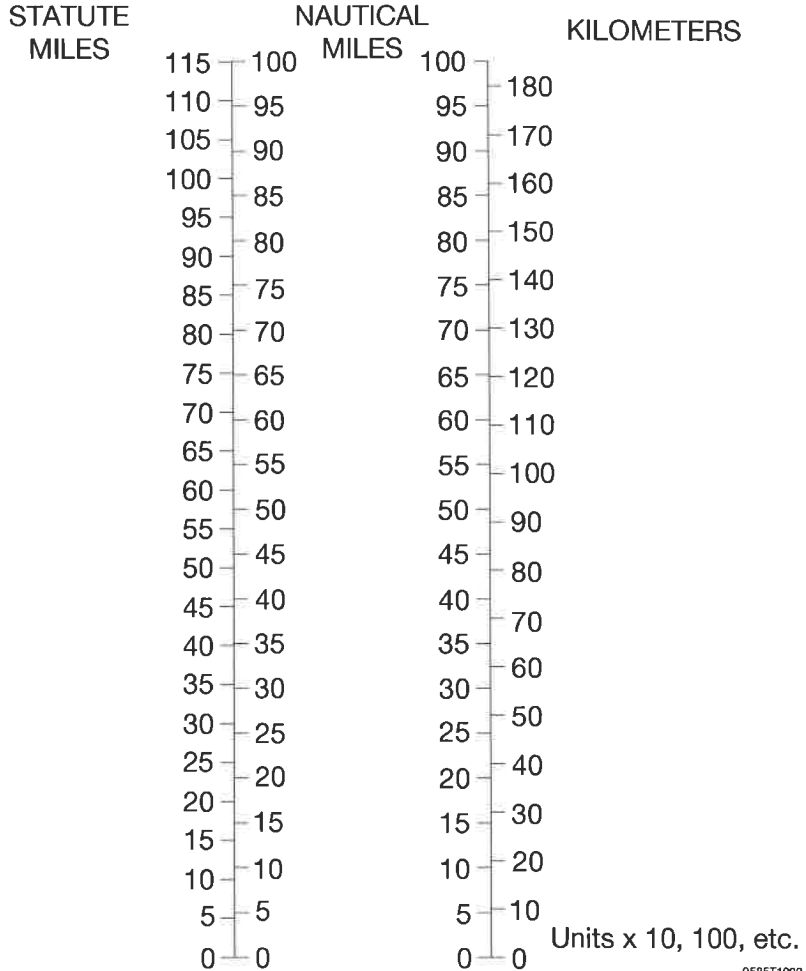

0585T1029

Figure 1-4

## VOLUME CONVERSIONS

B5722  
(Imperial Gallons x 4.546 = Liters) (Liters x .22 = Imperial Gallons)

### Liters into Imperial Gallons Litres en Gallons Imperial

Lt	0	1	2	3	4	5	6	7	8	9
	IG	IG	IG	IG	IG	IG	IG	IG	IG	IG
0	---	0.220	0.440	0.660	0.880	1.100	1.320	1.540	1.760	1.980
10	2.200	2.420	2.640	2.860	3.080	3.300	3.520	3.740	3.960	4.180
20	4.400	4.620	4.840	5.059	5.279	5.499	5.719	5.939	6.159	6.379
30	6.599	6.819	7.039	7.259	7.479	7.699	7.919	8.139	8.359	8.579
40	8.799	9.019	9.239	9.459	9.679	9.899	10.119	10.339	10.559	10.779
50	10.999	11.219	11.439	11.659	11.879	12.099	12.319	12.539	12.759	12.979
60	13.199	13.419	13.639	13.859	14.078	14.298	14.518	14.738	14.958	15.178
70	15.398	15.618	15.838	16.058	16.278	16.498	16.718	16.938	17.158	17.378
80	17.598	17.818	18.038	18.258	18.478	18.698	18.918	19.138	19.358	19.578
90	19.798	20.018	20.238	20.458	20.678	20.898	21.118	21.338	21.558	21.778
100	21.998	22.218	22.438	22.658	22.878	23.098	23.318	23.537	23.757	23.977

### Imperial Gallons into Liters Gallons Imperial en Litres

IG	0	1	2	3	4	5	6	7	8	9
	Lt	Lt	Lt	Lt	Lt	Lt	Lt	Lt	Lt	Lt
0	---	4.546	9.092	13.638	18.184	22.730	27.276	31.822	36.368	40.914
10	45.460	50.006	54.552	59.097	63.643	68.189	72.735	77.281	81.827	86.373
20	90.919	95.465	100.01	104.56	109.10	113.65	118.20	122.74	127.29	131.83
30	136.38	140.93	145.47	150.02	154.56	159.11	163.66	168.20	172.75	177.29
40	181.84	186.38	190.93	195.48	200.02	204.57	209.11	213.66	218.21	222.75
50	227.30	231.84	236.39	240.94	245.48	250.03	254.57	259.12	263.67	268.21
60	272.76	277.30	281.85	286.40	290.94	295.49	300.03	304.58	309.13	313.67
70	318.22	322.76	327.31	331.86	336.40	340.95	345.49	350.04	354.59	359.13
80	363.68	368.22	372.77	377.32	381.86	386.41	390.95	395.50	400.04	404.59
90	409.14	413.68	418.23	422.77	427.32	431.87	436.41	440.96	445.50	450.05
100	454.60	459.14	463.69	468.23	472.78	477.33	481.87	486.42	490.96	495.51

Figure 1-5 (Sheet 1 of 3)

## VOLUME CONVERSIONS

B3085

(Imperial Gallons X 4.546 = Liters)  
(Liters X .22 = Imperial Gallons)

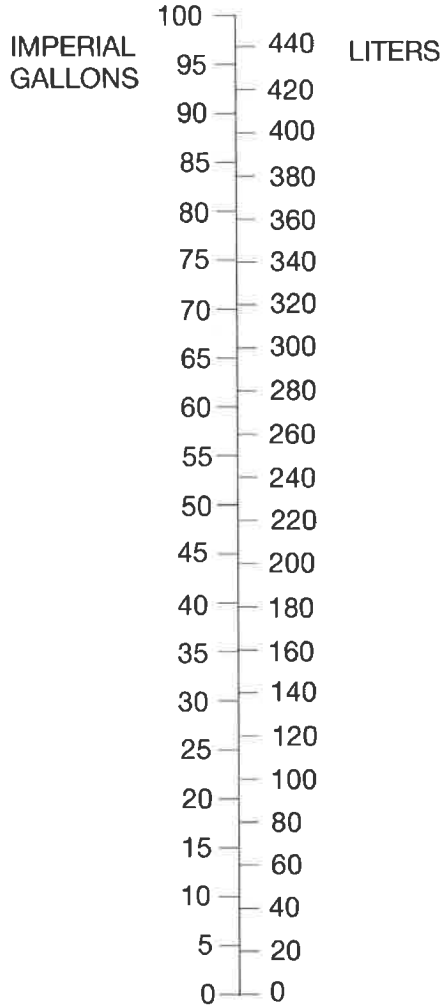

Units x 10, 100, etc.

0585T1032

Figure 1-5 (Sheet 2)

## VOLUME CONVERSIONS

B3068

(Imperial Gallons x 1.2 = U.S. Gallons)  
(U.S. Gallons x .833 = Imperial Gallons)  
(U.S. Gallons x 3.785 = Liters)  
(Liters x .264 = U.S. Gallons)

IMPERIAL  
GALLONS

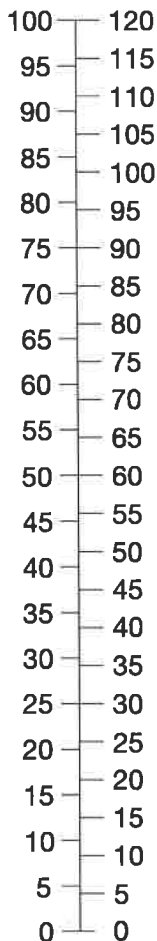

U.S.  
GALLONS

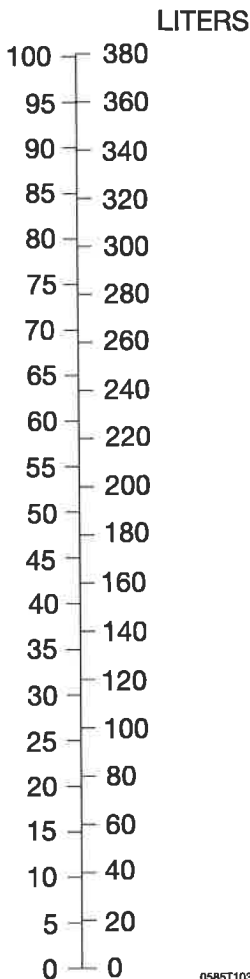

0585T1033

Figure 1-5 (Sheet 3)

## TEMPERATURE CONVERSIONS

B3087

$$(F - 32) \times 5/9 = ^\circ C \quad ^\circ C \times 9/5 + 32 = ^\circ F$$

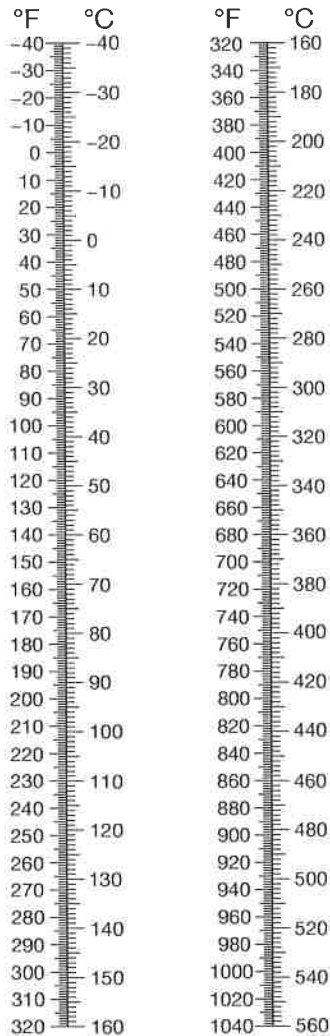

0585T1034

Figure 1-6

## PRESSURE CONVERSION

### HECTOPASCALS TO INCHES OF MERCURY

B3996

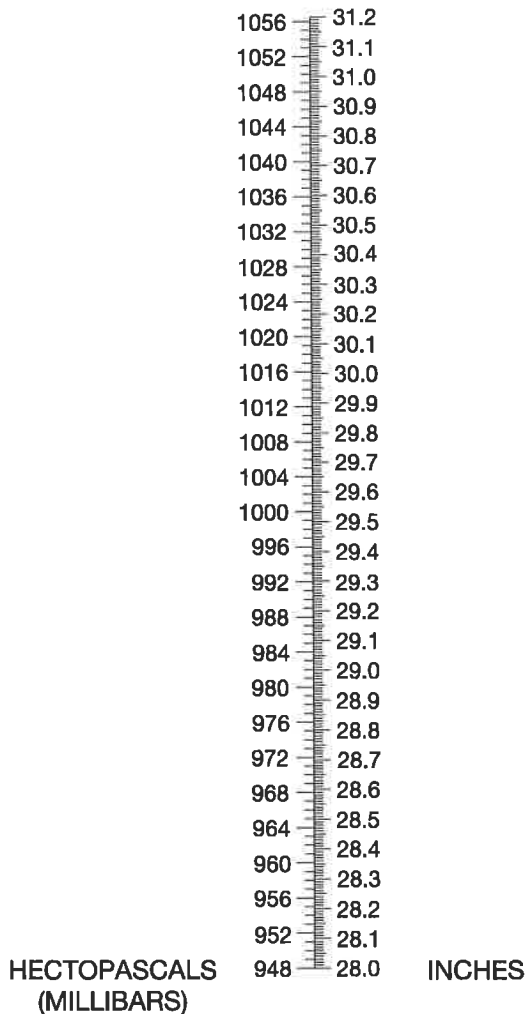

Figure 1-7

## VOLUME TO WEIGHT CONVERSION

B3088

AVGAS Specific Gravity = .72

(Liters x .72 = Kilograms)  
 (Liters x 1.58 = Pounds)

(Kilograms x 1.389 = Liters)  
 (Pounds x .633 = Liters)

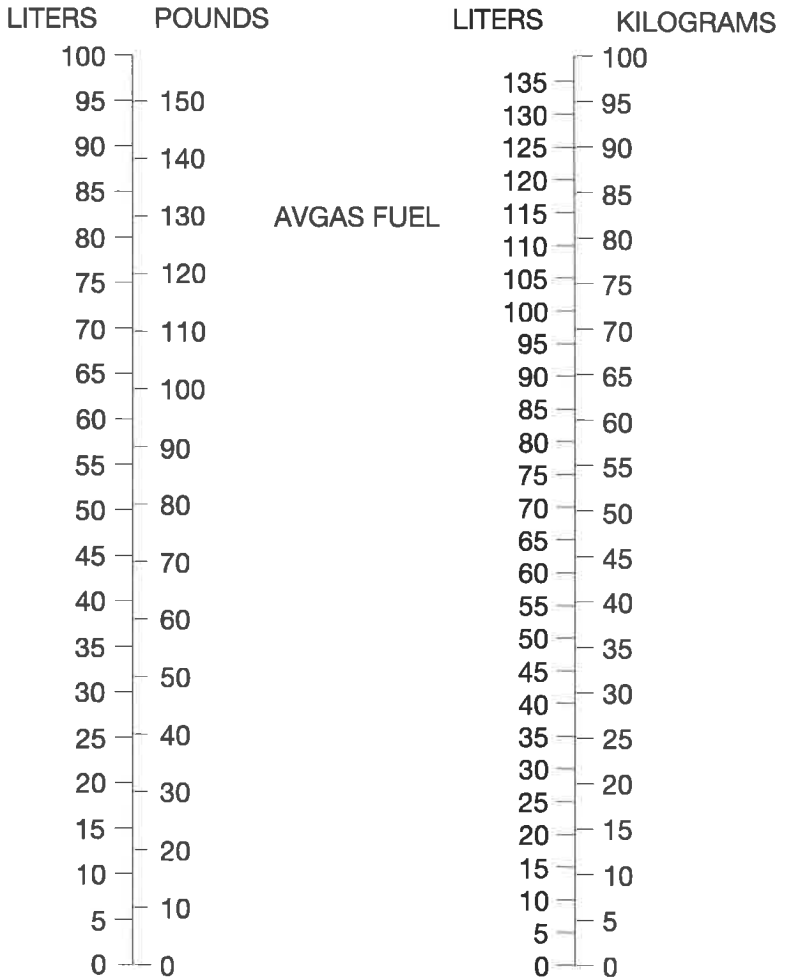

Units x 10, 100, etc.

0585T1030

Figure 1-8

## QUICK CONVERSIONS

B3086

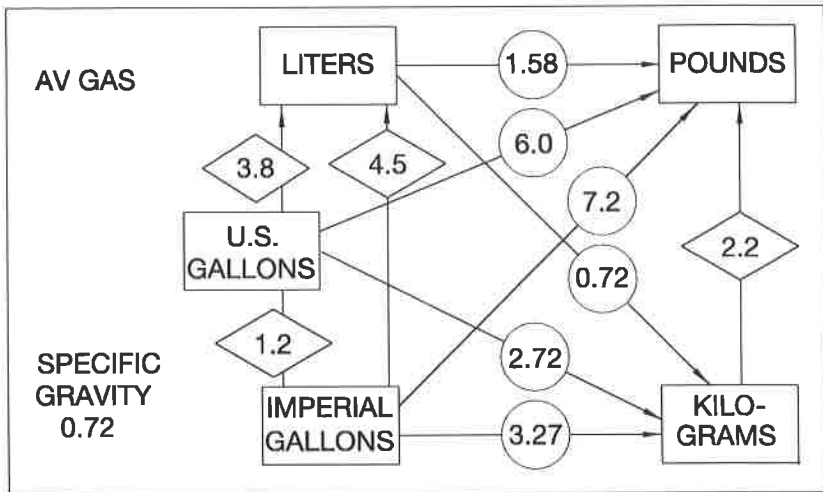

0685T1031

Figure 1-9

## OPERATING LIMITATIONS

### TABLE OF CONTENTS

	Page
Introduction . . . . .	2-3
Airspeed Limitations . . . . .	2-4
Airspeed Indicator Markings . . . . .	2-5
Powerplant Limitations . . . . .	2-6
Powerplant Instrument Markings . . . . .	2-7
Weight Limits . . . . .	2-8
Normal Category . . . . .	2-8
Maximum Weight in Baggage Compartment - Normal Category . . . . .	2-8
Utility Category . . . . .	2-8
Maximum Weight in Baggage Compartment - Utility Category . . . . .	2-8
Center Of Gravity Limits . . . . .	2-9
Normal Category . . . . .	2-9
Utility Category . . . . .	2-9
Maneuver Limits . . . . .	2-10
Normal Category . . . . .	2-10
Utility Category . . . . .	2-10
Flight Load Factor Limits . . . . .	2-11
Normal Category . . . . .	2-11
Utility Category . . . . .	2-11
Kinds Of Operations Limits . . . . .	2-12
Kinds Of Operations Equipment List . . . . .	2-13
Fuel Limitations . . . . .	2-18
Flap Limitations . . . . .	2-18
System Limitations . . . . .	2-19
Aux Audio System . . . . .	2-19
12V Power System (if installed) . . . . .	2-19
G1000 Limitations . . . . .	2-20
Garmin GFC 700 AFCS (if installed) . . . . .	2-21
Terrain Awareness and Warning System (TAWS-B) . . . . .	2-21
Other Limitations . . . . .	2-22
Placards . . . . .	2-23



## INTRODUCTION

Section 2 includes operating limitations, instrument markings, and basic placards necessary for the safe operation of the airplane, its engine, standard systems and standard equipment. The limitations included in this section and in Section 9 have been approved by the Federal Aviation Administration. Observance of these operating limitations is required by Federal Aviation Regulations.

### NOTE

- Refer to Supplements, Section 9 of this Pilot's Operating Handbook for amended operating limitations, operating procedures, performance data and other necessary information for airplanes equipped with specific options.
- The airspeeds listed in Figure 2-1, Airspeed Limitations, and Figure 2-2, Airspeed Indicator Markings, are based on Airspeed Calibration data shown in Section 5 with the normal static source. If the alternate static source is being used, ample margins should be observed to allow for the airspeed calibration variations between the normal and alternate static sources as shown in Section 5.

The Cessna Model No. 172S is certificated under FAA Type Certificate No. 3A12.

## AIRSPEED LIMITATIONS

Airspeed limitations and their operational significance are shown in Figure 2-1. Maneuvering speeds shown apply to normal category operations. The utility category maneuvering speed is 98 KIAS at 2200 pounds.

### AIRSPEED LIMITATIONS

SYMBOL	SPEED	KCAS	KIAS	REMARKS
V <sub>NE</sub>	Never Exceed Speed	160	163	Do not exceed this speed in any operation.
V <sub>NO</sub>	Maximum Structural Cruising Speed	126	129	Do not exceed this speed except in smooth air, and then only with caution.
V <sub>A</sub>	Maneuvering Speed: 2550 Pounds 2200 Pounds 1900 Pounds	102 95 88	105 98 90	Do not make full or abrupt control movements above this speed.
V <sub>FE</sub>	Maximum Flap Extended Speed: FLAPS 10° FLAPS 10° to FULL	107 85	110 85	Do not exceed this speed with flaps down.
-----	Maximum Window Open Speed	160	163	Do not exceed this speed with windows open.

Figure 2-1

## AIRSPEED INDICATOR MARKINGS

Airspeed indicator markings and their color code significance are shown in Figure 2-2.

### AIRSPEED INDICATOR MARKINGS

MARKING	KIAS VALUE OR RANGE	SIGNIFICANCE
Red Arc*	20 - 40	Low airspeed warning.
White Arc	40 - 85	Full Flap Operating Range. Lower limit is maximum weight $V_{SO}$ in landing configuration. Upper limit is maximum speed permissible with flaps extended.
Green Arc	48 - 129	Normal Operating Range. Lower limit is maximum weight $V_{S1}$ at most forward C.G. with flaps retracted. Upper limit is maximum structural cruising speed.
Yellow Arc	129 - 163	Operations must be conducted with caution and only in smooth air.
Red Line	163	Maximum speed for all operations.

\*G1000 airspeed indicator only.

Figure 2-2

## POWERPLANT LIMITATIONS

Engine Manufacturer: Textron Lycoming

Engine Model Number: IO-360-L2A

Maximum Power: 180 BHP Rating

Engine Operating Limits for Takeoff and Continuous Operations:

Maximum Engine Speed: . . . . . 2700 RPM

### NOTE

The static RPM range at full throttle is 2300 - 2400 RPM.

Maximum Oil Temperature: . . . . . 245°F (118°C)

Oil Pressure, Minimum: . . . . . 20 PSI

Oil Pressure, Maximum: . . . . . 115 PSI

### CAUTION

ENGINE OPERATION WITH INDICATED OIL PRESSURE BELOW THE GREEN BAND RANGE WHILE IN CRUISE OR CLIMB CONFIGURATION IS CONSIDERED ABNORMAL. REFER TO SECTION 3, AMPLIFIED EMERGENCY PROCEDURES, "LOW OIL PRESSURE".

Fuel Grade: Refer to Fuel Limitations

Oil Grade (Specification):

MIL-L-6082 or SAE J1966 Aviation Grade Straight Mineral Oil or MIL-L-22851 or SAE J1899 Ashless Dispersant Oil. Oil must comply with the latest revision and/or supplement for Textron Lycoming Service Instruction No. 1014, **must be used**.

Propeller Manufacturer: McCauley Propeller Systems

Propeller Model Number: 1A170E/JHA7660

Propeller Diameter:

Maximum . . . . . 76 INCHES

Minimum . . . . . 75 INCHES

## POWERPLANT INSTRUMENT MARKINGS

Powerplant instrument markings and their color code significance are shown in Figure 2-3. Operation with indications in the red range is prohibited. Avoid operating with indicators in the yellow range.

### POWERPLANT INSTRUMENT MARKINGS

INSTRUMENT	RED LINE (MIN)	RED ARC (LWR)	YELLOW ARC	GREEN ARC (NORMAL OPERATING RANGE)	RED ARC (UPR)
Tachometer Sea Level 5000 Feet 10,000 Feet	----	----	----	2100 to 2500 2100 to 2600 2100 to 2700 RPM	2700* to 3000 RPM
Cylinder Head Temperature	----	----	----	200 to 500°F	----
Oil Temperature	----	----	----	100 to 245°F	245* to 250°F
Oil Pressure	----	0 to 20 PSI	----	50 to 90 PSI	115* to 120 PSI
Fuel Quantity	0 (1.5 Gallons Unusable Each Tank)	----	0 to 5 Gallons	5 to 24 Gallons	----
Fuel Flow	----	----	----	0 to 12 GPH	----
Vacuum Indicator (if installed)	----	----	----	4.5 to 5.5 in.hg.	----

\*Maximum operating limit is lower end of red arc.

Figure 2-3\*

## WEIGHT LIMITS

### NORMAL CATEGORY

Maximum Ramp Weight: . . . . . 2558 POUNDS  
Maximum Takeoff Weight: . . . . . 2550 POUNDS  
Maximum Landing Weight: . . . . . 2550 POUNDS

### MAXIMUM WEIGHT IN BAGGAGE COMPARTMENT - NORMAL CATEGORY:

Baggage Area A - Station 82 to 108: . . . . . 120 POUNDS  
. . . . . Refer to note below.  
Baggage Area B - Station 108 to 142: . . . . . 50 POUNDS  
. . . . . Refer to note below.

### NOTE

The maximum allowable combined weight capacity for baggage in areas A and B is 120 pounds.

### UTILITY CATEGORY

Maximum Ramp Weight: . . . . . 2208 POUNDS  
Maximum Takeoff Weight: . . . . . 2200 POUNDS  
Maximum Landing Weight: . . . . . 2200 POUNDS

### MAXIMUM WEIGHT IN BAGGAGE COMPARTMENT - UTILITY CATEGORY:

The baggage compartment must be empty and rear seat must not be occupied.

## **CENTER OF GRAVITY LIMITS**

### **NORMAL CATEGORY**

Center Of Gravity Range:

Forward: 35.0 inches aft of datum at 1950 pounds or less, with straight line variation to 41.0 inches aft of datum at 2550 pounds.

Aft: 47.3 inches aft of datum at all weights.

Reference Datum: Lower portion of front face of firewall.

### **UTILITY CATEGORY**

Center of Gravity Range:

Forward: 35.0 inches aft of datum at 1950 pounds or less, with straight line variation to 37.5 inches aft of datum at 2200 pounds.

Aft: 40.5 inches aft of datum at all weights.

Reference Datum: Lower portion of front face of firewall.

## MANEUVER LIMITS

### NORMAL CATEGORY

This airplane is certificated in both the normal and utility category. The normal category is applicable to aircraft intended for non aerobatic operations. These include any maneuvers incidental to normal flying, stalls (except whip stalls), lazy eights, chandelles, and turns in which the angle of bank is not more than 60°.

### NORMAL CATEGORY MANEUVERS AND RECOMMENDED ENTRY SPEED\*

Chandelles . . . . .	105 KNOTS
Lazy Eights . . . . .	105 KNOTS
Steep Turns . . . . .	95 KNOTS
Stalls (Except Whip Stalls) . . . . .	Slow Deceleration

**\* Abrupt use of the controls is prohibited above 105 KNOTS.**

### UTILITY CATEGORY

This airplane is not designed for purely aerobatic flight. However, in the acquisition of various certificates such as commercial pilot and flight instructor, certain maneuvers are required by the FAA. All of these maneuvers are permitted in this airplane when operated in the utility category.

In the utility category, the rear seat must not be occupied and the baggage compartment must be empty.

### UTILITY CATEGORY MANEUVERS AND RECOMMENDED ENTRY SPEED\*

Chandelles . . . . .	105 KNOTS
Lazy Eights . . . . .	105 KNOTS
Steep Turns . . . . .	95 KNOTS
Spins . . . . .	Slow Deceleration
Stalls (Except Whip Stalls) . . . . .	Slow Deceleration

**\* Abrupt use of the controls is prohibited above 98 KNOTS.**

(Continued Next Page)

## **MANEUVER LIMITS (Continued)**

### **UTILITY CATEGORY (Continued)**

Aerobatics that may impose high loads should not be attempted. The important thing to bear in mind in flight maneuvers is that the airplane is clean in aerodynamic design and will build up speed quickly with the nose down. Proper speed control is an essential requirement for execution of any maneuver, and care should always be exercised to avoid excessive speed which in turn can impose excessive loads. In the execution of all maneuvers, avoid abrupt use of controls.

## **FLIGHT LOAD FACTOR LIMITS**

### **NORMAL CATEGORY**

Flight Load Factors (Maximum Takeoff Weight - 2550 POUNDS):

- \*Flaps UP: . . . . . +3.8g, -1.52g
- \*Flaps FULL: . . . . . +3.0g

### **UTILITY CATEGORY**

Flight Load Factors (Maximum Takeoff Weight - 2200 POUNDS):

- \*Flaps UP: . . . . . +4.4g, -1.76g
- \*Flaps FULL: . . . . . +3.0g

## **KINDS OF OPERATIONS LIMITS**

The Cessna 172S Nav III airplane is approved for day and night, VFR and IFR operations. Flight into known icing conditions is prohibited.

The minimum equipment for approved operations required under the Operating Rules are defined by 14 CFR 91 and 14 CFR 135, as applicable.

The following Kinds of Operations Equipment List (KOEL) identifies the equipment required to be operational for airplane airworthiness in the listed kind of operations.

**KINDS OF OPERATIONS EQUIPMENT LIST**

System, Instrument, Equipment and/or Function	KIND OF OPERATION				COMMENTS
	VFR DAY	VFR NIGHT	IFR DAY	IFR NIGHT	
<b>PLACARDS AND MARKINGS</b>					
1 - 172S Nav III - GFC 700 AFCS POH/AFM	1	1	1	1	Accessible to pilot in flight.
2 - Garmin G1000 Cockpit Reference Guide	1	1	1	1	Accessible to pilot in flight.
<b>AIR CONDITIONING</b>					
1 - Forward Avionics Fan	1	1	1	1	
2 - PFD Fan	0	0	0	0	
3 - MFD Fan	0	0	0	0	
4 - Aft Avionics Fan	1	1	1	1	
<b>COMMUNICATIONS</b>					
1 - VHF COM	0	0	1	1	
<b>ELECTRICAL POWER</b>					
1 - 24V Main Battery	1	1	1	1	
2 - 28V Alternator	1	1	1	1	
3 - 24V Standby Battery	0	*	*	*	* Refer to Note 1.
4 - Main Ammeter	1	1	1	1	
5 - Standby Ammeter	0	*	*	*	* Refer to Note 1.

**NOTE**

1. The European Aviation Safety Agency (EASA) requires the 24V Standby Battery and Standby Ammeter to successfully complete the pre-flight check before operating the airplane in VFR night, IFR day, or IFR night conditions in Europe. Correct operation of the 24V Standby Battery and Standby Ammeter is recommended for all other operations.

(Continued Next Page)

**KINDS OF OPERATIONS EQUIPMENT LIST** (Continued)

System, Instrument, Equipment and/or Function	KIND OF OPERATION				COMMENTS
	V F R  D A Y	V F R  N I G H T	I F R  D A Y	I F R  N I G H T	
<b>EQUIPMENT AND FURNISHINGS</b>					
1 - Seat Belt Assembly	1	1	1	1	Each Seat Occupant
2 - Shoulder Harness	1	1	1	1	Front Seat Occupants
<b>FLIGHT CONTROLS</b>					
1 - Flap Position Indicator	1	1	1	1	
2 - Flap Motor	1	1	1	1	
3 - Elevator Trim System	1	1	1	1	
4 - Elevator Trim Indicator	1	1	1	1	
<b>FUEL SYSTEM</b>					
1 - Electric Fuel Pump	1	1	1	1	
2 - Fuel Quantity Indicator - L Tank	1	1	1	1	
3 - Fuel Quantity Indicator - R Tank	1	1	1	1	
<b>ICE AND RAIN PROTECTION</b>					
1 - Alternate Static Air Source	0	0	1	1	
2 - Alternate Induction Air System	0	0	1	1	
<b>INDICATING/RECORDING SYSTEM</b>					
1 - Stall Warning System	1	1	1	1	
2 - System Annunciator and Warning Displays	1	1	1	1	
<b>LANDING GEAR</b>					
1 - Wheel Fairings	0	0	0	0	Removable
<b>LIGHTING</b>					
1 - PFD Bezel Lighting	0	0	0	1	
2 - PFD Backlighting	*	1	1	1	*Refer to Note 2.

(Continued Next Page)

**KINDS OF OPERATIONS EQUIPMENT LIST** (Continued)

System, Instrument, Equipment and/or Function	KIND OF OPERATION				COMMENTS
	V	V	I	I	
	F	F	F	F	
	R	R	R	R	
	D	N	D	N	
	A	I	A	I	
	Y	G	Y	G	
		H		H	
		T		T	
<b>LIGHTING (Continued)</b>					
3 - MFD Bezel Lighting	0	0	0	1	
4 - MFD Backlighting	*	1	1	1	*Refer to Note 3.
5 - Switch and Circuit Breaker Panel Lighting	0	1	0	1	
6 - Standby Airspeed Indicator Internal Lighting (if installed)	0	0	0	1	
7 - Standby Altimeter Internal Lighting (if installed)	0	0	0	1	
8 - Non-stabilized Magnetic Compass Internal Lighting	0	1	0	1	
9 - Standby Attitude Indicator Internal Lighting (if installed)	0	0	0	1	
10 - Standby Flight Instrument Backlighting (if installed)	0	0	1	1	
11 - Cockpit Flood Light	0	1	0	1	
12 - Aircraft Position (NAV) Lights	0	1	0	1	
13 - STROBE Light System	1	1	1	1	
14 - BEACON Light	0	0	0	0	
15 - TAXI Light	0	0	0	0	
16 - LAND (Landing) Light	0	1	0	1	Refer to Note 4.

**NOTE**

2. PFD backlighting is required for day VFR flight if MFD backlighting has failed. Display backup mode must be active so engine indicators are shown.
3. MFD backlighting is required for day VFR flight if PFD backlighting has failed. Display backup mode must be active so flight instruments are shown.
4. Operations for hire only. Landing light required for airplanes equipped with single HID landing/taxi light. For airplanes equipped with dual LED landing/taxi lights, a single LED landing/taxi light assembly must be operating on either wing, with all 18 LED bulbs operational.

(Continued Next Page)

**KINDS OF OPERATIONS EQUIPMENT LIST** (Continued)

System, Instrument, Equipment and/or Function	KIND OF OPERATION				COMMENTS
	V F R	V F R	I F R	I F R	
	D A Y	N I G H T	D A Y	N I G H T	
<b>NAVIGATION AND PITOT-STATIC SYSTEM</b>					
1 - G1000 Airspeed Indicator	1	1	1	1	
2 - Standby Airspeed Indicator (if installed)	0	0	1	1	
3 - G1000 Altimeter	1	1	1	1	
4 - Standby Altimeter (if installed)	0	0	1	1	
5 - G1000 Vertical Speed Indicator	0	0	0	0	
6 - G1000 Attitude Indicator	0	0	1	1	
7 - Standby Attitude Indicator (if installed)	0	0	1	1	
8 - Standby Flight Instrument (if installed)	0	0	1	1	
9 - G1000 Directional Indicator (HSI)	0	0	1	1	
10 - G1000 Turn Coordinator	0	0	1	1	
11 - Non-stabilized Magnetic Compass	1	1	1	1	
12 - VHF Navigation Radio (VOR/LOC/GS)	0	0	A/R	A/R	As Required Per Procedure.
13 - GPS Receiver/Navigator	0	0	A/R	A/R	As Required Per Procedure.
14 - Marker Beacon Receiver	0	0	A/R	A/R	As Required Per Procedure.
15 - Blind Altitude Encoder	A/R	A/R	1	1	As Required Per Procedure.
16 - Clock	0	0	1	1	
17 - GFC 700 AFCS (if installed)	0	0	0	0	

(Continued Next Page)

**KINDS OF OPERATIONS EQUIPMENT LIST** (Continued)

System, Instrument, Equipment and/or Function	KIND OF OPERATION				COMMENTS
	V F R  D A Y	V F R  N I G H T	I F R  D A Y	I F R  N I G H T	
<b>VACUUM</b>					
1 - Engine Driven Vacuum Pump (if installed)	0	0	1	1	
2 - Vacuum Indicator (if installed)	0	0	1	1	
<b>ENGINE FUEL AND CONTROL</b>					
1 - Fuel Flow Indicator	1	1	1	1	
<b>ENGINE INDICATING</b>					
1 - Tachometer (RPM)	1	1	1	1	
2 - Cylinder Head Temperature (CHT) Indicator	0	0	0	0	
3 - Oil Pressure Indicator	1	1	1	1	
4 - Oil Temperature Indicator	1	1	1	1	
<b>ENGINE OIL</b>					
1 - Engine Crankcase Dipstick	1	1	1	1	

## FUEL LIMITATIONS

Total Fuel: .....56.0 U.S. GALLONS  
(28.0 GALLONS per tank)  
Usable Fuel (all flight conditions): .....53.0 U.S. GALLONS  
(26.5 GALLONS per tank)  
Unusable Fuel: .....3.0 U.S. GALLONS  
(1.5 GALLONS per tank)

### NOTE

To ensure maximum fuel capacity and minimize crossfeeding when refueling, always park the airplane in a wings level, normal ground attitude and place the fuel selector in the LEFT or RIGHT position. Refer to Figure 1-1 for normal ground attitude definition.

Takeoff and land with the fuel selector valve handle in the BOTH position.

Maximum slip or skid duration with one tank dry: 30 seconds

Operation on either LEFT or RIGHT tank limited to level flight only.

With 1/4 tank or less, prolonged uncoordinated flight is prohibited when operating on either left or right tank.

Fuel remaining in the tank after the fuel quantity indicator reads 0 (red line) cannot be safely used in flight.

Approved Fuel Grades (And Colors):

- 100LL Grade Aviation Fuel (Blue)
- 100 Grade Aviation Fuel (Green)

## FLAP LIMITATIONS

Approved Takeoff Range: ..... UP to 10°  
Approved Landing Range: ..... UP to FULL

## SYSTEM LIMITATIONS

### AUX AUDIO SYSTEM

Use of the AUX AUDIO IN entertainment input is prohibited during takeoff and landing.

Use of the AUX AUDIO IN entertainment audio input and portable electronic devices (PED), such as cellular telephones, games, cassette, CD or MP3 players, is prohibited under IFR unless the operator of the airplane has determined that the use of the Aux Audio System and the connected portable electronic device(s) will not cause interference with the navigation or communication system of the airplane.

### 12V POWER SYSTEM (if installed)

The 12 Volt Power System (POWER OUTLET 12V - 10A) is not certified for supplying power to flight-critical communications or navigation devices.

Use of the 12 Volt Power System is prohibited during takeoff and landing.

Use of the 12 Volt Power System is prohibited under IFR unless the operator of the airplane has determined that the use of the 12 VDC power supply and connected portable electronic device(s) will not cause interference with the navigation or communication systems of the airplane.

## G1000 LIMITATIONS

The current Garmin G1000 Cockpit Reference Guide (CRG) Part Number and System Software Version that must be available to the pilot during flight are displayed on the MFD AUX group, SYSTEM STATUS page.

GPS based IFR enroute, oceanic and terminal navigation is prohibited unless the pilot verifies the currency of the database or verifies each selected waypoint for accuracy by reference to current approved data.

RNAV/GPS instrument approaches must be accomplished in accordance with approved instrument approach procedures that are retrieved from the G1000 navigation database. The G1000 database must incorporate the current update cycle.

Use of the TRAFFIC MAP to maneuver the airplane to avoid traffic is prohibited. The Traffic Information System (TIS) is intended for advisory use only. TIS is intended only to help the pilot to visually locate traffic. It is the responsibility of the pilot to see and maneuver to avoid traffic.

Use of the TERRAIN PROXIMITY information for primary terrain avoidance is prohibited. The Terrain Proximity map is intended only to enhance situational awareness. It is the pilot's responsibility to provide terrain clearance at all times.

Use of the NAVIGATION MAP page for pilotage navigation is prohibited. The Navigation Map is intended only to enhance situational awareness. Navigation is to be conducted using only current charts, data and authorized navigation facilities.

Navigation using the G1000 is not authorized North of 72° North latitude or South of 70° South latitude due to unsuitability of the magnetic fields near the Earth's poles. In addition, operations are not authorized in the following regions:

1. North of 65° North latitude between longitude 75° W and 120° W (Northern Canada).
2. North of 70° North latitude between longitude 70° W and 128° W (Northern Canada).
3. North of 70° North latitude between longitude 85° E and 114° E (Northern Russia).
4. South of 55° South latitude between longitude 120° E and 165° E (region south of Australia and New Zealand).

(Continued Next Page)

## **G1000 LIMITATIONS** (Continued)

The COM 1/2 (split COM) function of the Audio Panel is not approved for use. During COM 1/2 operation, transmission by one crew member inhibits reception by the other crew member.

The fuel quantity, fuel used and fuel remaining functions of the G1000 are supplemental information only and must be verified by the pilot.

## **GARMIN GFC 700 AFCS** (if installed)

1. The GFC 700 AFCS preflight test must be successfully completed prior to use of the autopilot, flight director or manual electric trim.
2. A pilot, with the seat belt fastened, must occupy the left pilot's seat during all autopilot operations.
3. The autopilot must be off during all takeoff and landings.
4. Autopilot maximum engagement speed - 150 KIAS.  
Autopilot minimum engagement speed - 70 KIAS.  
Electric Trim maximum operating speed - 163 KIAS.
5. Maximum fuel imbalance with autopilot engaged - 90 pounds.
6. The autopilot must be disengaged below 200 feet AGL during approach operations and below 800 feet AGL during all other operations.
7. ILS approaches using the autopilot/flight director are limited to Category I approaches only.
8. Use of the autopilot is prohibited when the audio panel is inoperative (since the aural alert will not be provided when autopilot is disengaged).
9. Use of the autopilot is prohibited when conducting missed approach procedures until an established rate of climb that ensures all altitude requirements of the procedure will be met.

## **TERRAIN AWARENESS AND WARNING SYSTEM (TAWS-B)**

Use of the Terrain Awareness and Warning System (TAWS-B) to navigate to avoid terrain or obstacles is prohibited. TAWS-B is only approved as an aid to help the pilot to see-and-avoid terrain or obstacles.

(Continued Next Page)

## **G1000 LIMITATIONS** (Continued)

TAWS-B must be inhibited when landing at a location not included in the airport database.

Use of TAWS-B is prohibited when operating using the QFE altimeter setting (altimeter indicates 0 feet altitude when the airplane is on the runway).

The pilot is authorized to deviate from the current ATC clearance only to the extent necessary to comply with TAWS-B warnings.

The geographic area of the TAWS-B database must match the geographic area in which the airplane is being operated.

### **Serials 172S10468, 172S10507, 172S10640 and 172S10656 thru 172S10775 not incorporating SB08-34-03**

Flight operations are prohibited over large bodies of sea level water if that flight is conducted under operating regulations that require a functioning TAWS.

### **CAUTION**

TAWS-B FORWARD LOOKING TERRAIN AVOIDANCE (FLTA) IS NOT AVAILABLE WHEN FLYING OVER THE OPEN OCEAN/SEA (SPECIFICALLY ANY BODY OF WATER AT SEA LEVEL, MORE THAN 6NM FROM ANY TERRAIN FEATURES) UNTIL TERRAIN DATABASE 08T2 OR LATER IS INSTALLED. DO NOT USE TAWS-B INFORMATION FOR PRIMARY TERRAIN AVOIDANCE. TAWS-B IS INTENDED ONLY TO ENHANCE SITUATIONAL AWARENESS.

## **OTHER LIMITATIONS**

### **ADS-B SYSTEM**

The installed ADS-B OUT system has been shown to meet the equipment requirements of 14 CFR 91.227, if a GTX 33 ES Transponder and Cessna System Software 0563.30 or later version is installed. If installed, this transponder is 1090 MHz ES approved to operate in Class A airspace.

## PLACARDS

The following information must be displayed in the form of composite or individual placards.

1. In full view of the pilot: (The "DAY-NIGHT-VFR-IFR" entry, shown on the example below, will vary with installed equipment).

B7641

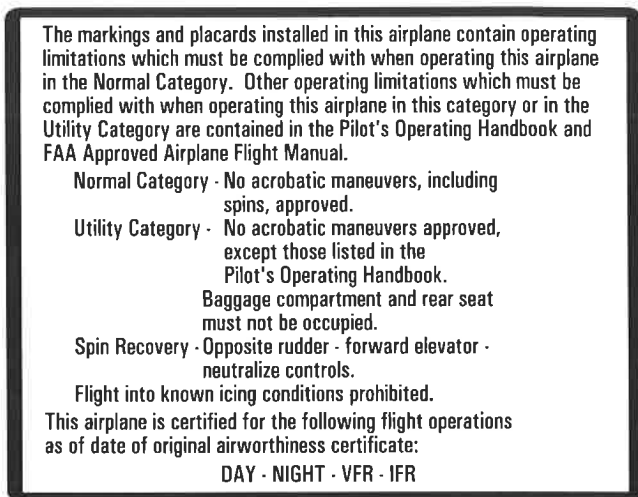

2. On control lock:

B6143



(Continued Next Page)

**PLACARDS** (Continued)

3. On the fuel selector valve:

B7652

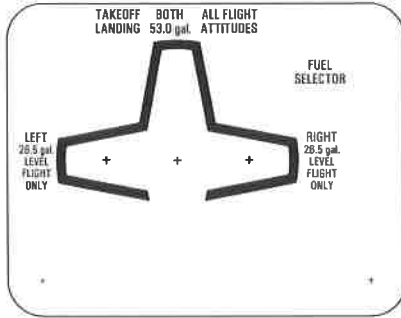

4. Near both fuel tank filler cap:

B7645

**FUEL**  
**100LL / 100 MIN. GRADE AVIATION GASOLINE**  
**CAP. 26.5 U.S. GAL. (100 LITRES) USABLE**  
**CAP. 17.5 U.S. GAL. (66 LITRES) USABLE**  
**TO BOTTOM OF FILLER INDICATOR TAB.**

(Continued Next Page)

## PLACARDS (Continued)

5. On flap control indicator:

B7646

UP to 10°                      110 KIAS  
(Partial flap range with blue color code;  
mechanical detent at 10° position)

10° to FULL                      85 KIAS  
(White color code; mechanical  
detent at 20° position)

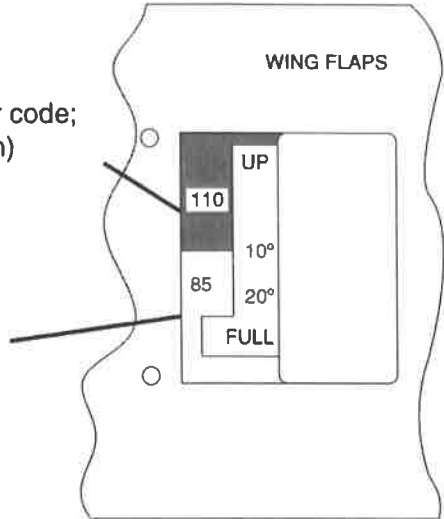

6. In baggage compartment:

B7647

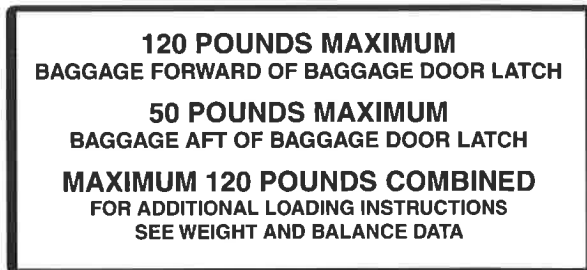

(Continued Next Page)

**PLACARDS** (Continued)

7. A calibration card must be provided to indicate the accuracy of the magnetic compass in 30° increments.

B6148

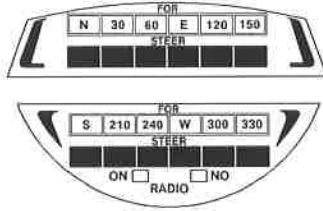

8. Molded on the oil filler cap/dipstick:

B7648



9. Silk-screened on the instrument panel directly above the PFD:

B7938

**MANEUVERING SPEED: 105 KIAS**

(Continued Next Page)

**PLACARDS** (Continued)

10. Silk-screened on the upper right instrument panel:

B6151

**SMOKING PROHIBITED**

11. On auxiliary power plug door and second placard on battery box:

B6152

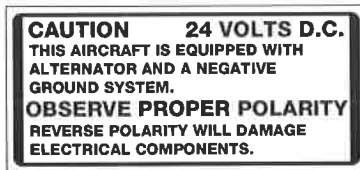

12. On the upper right side of the aft cabin partition:

B6153



OR

B7651



(Continued Next Page)

**PLACARDS** (Continued)

13. On the center overhead flood light control switch:

B6154

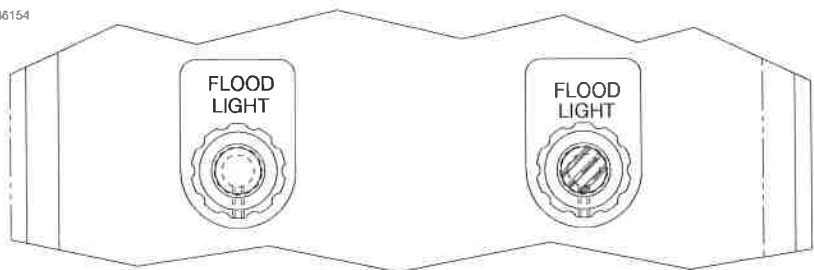

## EMERGENCY PROCEDURES

### TABLE OF CONTENTS

	Page
Introduction .....	3-5
Airspeeds For Emergency Operations.....	3-5
<b>EMERGENCY PROCEDURES .....</b>	<b>3-6</b>
<b>ENGINE FAILURES .....</b>	<b>3-6</b>
Engine Failure During Takeoff Roll .....	3-6
Engine Failure Immediately After Takeoff .....	3-6
Engine Failure During Flight (Restart Procedures).....	3-7
<b>FORCED LANDINGS .....</b>	<b>3-8</b>
Emergency Landing Without Engine Power .....	3-8
Precautionary Landing With Engine Power.....	3-8
Ditching .....	3-9
<b>FIRES .....</b>	<b>3-10</b>
During Start On Ground .....	3-10
Engine Fire In Flight .....	3-11
Electrical Fire In Flight.....	3-11
Cabin Fire .....	3-12
Wing Fire.....	3-13
<b>ICING .....</b>	<b>3-14</b>
Inadvertent Icing Encounter During Flight.....	3-14
<b>STATIC SOURCE BLOCKAGE .....</b>	<b>3-15</b>
(Erroneous Instrument Reading Suspected).....	3-15
<b>EXCESSIVE FUEL VAPOR.....</b>	<b>3-15</b>
Fuel Flow Stabilization Procedures.....	3-15

(Continued Next Page)

## TABLE OF CONTENTS (Continued)

	Page
<b>ABNORMAL LANDINGS</b> . . . . .	3-16
Landing With A Flat Main Tire . . . . .	3-16
Landing With A Flat Nose Tire . . . . .	3-16
<b>ELECTRICAL POWER SUPPLY SYSTEM MALFUNCTIONS</b> . . . . .	3-17
High Volts Annunciator Comes On or M BATT AMPS More Than 40 . . . . .	3-17
LOW VOLTS Annunciator Comes On Below 1000 RPM . . . . .	3-19
LOW VOLTS Annunciator Comes On or Does Not Go Off at Higher RPM . . . . .	3-19
<b>AIR DATA SYSTEM FAILURE</b> . . . . .	3-21
Red X - PFD Airspeed Indicator . . . . .	3-21
Red X - PFD Altitude Indicator . . . . .	3-21
<b>ATTITUDE AND HEADING REFERENCE SYSTEM (AHRS) FAILURE</b> . . . . .	3-21
Red X - PFD Attitude Indicator . . . . .	3-21
Red X - Horizontal Situation Indicator (HSI) . . . . .	3-21
<b>AUTOPILOT OR ELECTRIC TRIM FAILURE (if installed)</b> . . . . .	3-22
AP or PTRM Annunciator(s) Come On . . . . .	3-22
<b>VACUUM SYSTEM FAILURE (if installed)</b> . . . . .	3-23
LOW VACUUM Annunciator Comes On . . . . .	3-23
<b>HIGH CARBON MONOXIDE (CO) LEVEL ADVISORY</b> . . . . .	3-24
CO LVL HIGH Annunciator Comes On . . . . .	3-24
CO LVL HIGH Annunciator Remains On . . . . .	3-24

(Continued Next Page)

**TABLE OF CONTENTS** (Continued)

	Page
<b>AMPLIFIED EMERGENCY PROCEDURES</b> .....	3-25
Engine Failure .....	3-25
Maximum Glide .....	3-26
Forced Landings .....	3-27
Landing Without Elevator Control .....	3-28
Fires .....	3-28
Emergency Operation In Clouds .....	3-29
Executing A 180° Turn In Clouds (AHRS FAILED) .....	3-29
Emergency Descent Through Clouds (AHRS FAILED) .....	3-30
Recovery From Spiral Dive In The Clouds (AHRS FAILED) . . .	3-31
Inadvertent Flight Into Icing Conditions .....	3-31
Static Source Blocked .....	3-32
Spins .....	3-32
Rough Engine Operation Or Loss Of Power .....	3-33
Spark Plug Fouling .....	3-33
Magneto Malfunction .....	3-33
Idle Power Engine Roughness .....	3-33
Engine-Driven Fuel Pump Failure .....	3-34
Excessive Fuel Vapor .....	3-34
Low Oil Pressure .....	3-35
Electrical Power Supply System Malfunctions .....	3-36
Excessive Rate Of Charge .....	3-36
Insufficient Rate Of Charge .....	3-37
High Carbon Monoxide (CO) Level Annunciation .....	3-39/3-40
Other Emergencies .....	3-39/3-40
Windshield Damage .....	3-39/3-40



## INTRODUCTION

Section 3 provides checklist and amplified procedures for coping with emergencies that may occur. Emergencies caused by airplane or engine malfunctions are extremely rare if proper preflight inspections and maintenance are practiced. Enroute weather emergencies can be minimized or eliminated by careful flight planning and good judgment when unexpected weather is encountered. However, should an emergency arise, the basic guidelines described in this section should be considered and applied as necessary to correct the problem. In any emergency situation, the most important task is continued control of the airplane and maneuver to execute a successful landing.

Emergency procedures associated with optional or supplemental equipment are found in Section 9, Supplements.

## AIRSPEEDS FOR EMERGENCY OPERATIONS

### ENGINE FAILURE AFTER TAKEOFF

Wing Flaps UP .....	70 KIAS
Wing Flaps 10° - FULL .....	65 KIAS

### MANEUVERING SPEED

2550 POUNDS .....	105 KIAS
2200 POUNDS .....	98 KIAS
1900 POUNDS .....	90 KIAS

**MAXIMUM GLIDE** ..... 68 KIAS

**PRECAUTIONARY LANDING WITH ENGINE POWER.** ..... 65 KIAS

### LANDING WITHOUT ENGINE POWER

Wing Flaps UP .....	70 KIAS
Wing Flaps 10° - FULL .....	65 KIAS

## EMERGENCY PROCEDURES

Procedures in the Emergency Procedures Checklist portion of this section shown in **bold faced** type are immediate action items which should be committed to memory.

## ENGINE FAILURES

### ENGINE FAILURE DURING TAKEOFF ROLL

1. **Throttle Control - IDLE (pull full out)**
2. **Brakes - APPLY**
3. Wing Flaps - RETRACT
4. Mixture Control - IDLE CUTOFF (pull full out)
5. MAGNETOS Switch - OFF
6. STBY BATT Switch - OFF
7. MASTER Switch (ALT and BAT) - OFF

### ENGINE FAILURE IMMEDIATELY AFTER TAKEOFF

1. **Airspeed - 70 KIAS - Flaps UP**  
**65 KIAS - Flaps 10° - FULL**
2. Mixture Control - IDLE CUTOFF (pull full out)
3. FUEL SHUTOFF Valve - OFF (pull full out)
4. MAGNETOS Switch - OFF
5. Wing Flaps - AS REQUIRED (FULL recommended)
6. STBY BATT Switch - OFF
7. MASTER Switch (ALT and BAT) - OFF
8. Cabin Door - UNLATCH
9. Land - STRAIGHT AHEAD

(Continued Next Page)

## **ENGINE FAILURES** (Continued)

### **ENGINE FAILURE DURING FLIGHT (Restart Procedures)**

1. **Airspeed - 68 KIAS (best glide speed)**
2. **FUEL SHUTOFF Valve - ON (push full in)**
3. **FUEL SELECTOR Valve - BOTH**
4. **FUEL PUMP Switch - ON**
5. **Mixture Control - RICH (if restart has not occurred)**
6. **MAGNETOS Switch - BOTH (or START if propeller is stopped)**

#### **NOTE**

If the propeller is windmilling, engine will restart automatically within a few seconds. If propeller has stopped (possible at low speeds), turn MAGNETOS switch to START, advance throttle slowly from idle and lean the mixture from full rich as required to obtain smooth operation.

7. **FUEL PUMP Switch - OFF**

#### **NOTE**

If the indicated fuel flow (FFLOW GPH) immediately drops to zero, a sign of failure of the engine-driven fuel pump, return the FUEL PUMP switch to the ON position.

## **FORCED LANDINGS**

### **EMERGENCY LANDING WITHOUT ENGINE POWER**

1. Pilot and Passenger Seat Backs - MOST UPRIGHT POSITION
2. Seats and Seat Belts - SECURE
3. Airspeed - 70 KIAS - Flaps UP  
65 KIAS - Flaps 10° - FULL
4. Mixture Control - IDLE CUTOFF (pull full out)
5. FUEL SHUTOFF Valve - OFF (pull full out)
6. MAGNETOS Switch - OFF
7. Wing Flaps - AS REQUIRED (FULL recommended)
8. STBY BATT Switch - OFF
9. MASTER Switch (ALT and BAT) - OFF (when landing is assured)
10. Doors - UNLATCH PRIOR TO TOUCHDOWN
11. Touchdown - SLIGHTLY TAIL LOW
12. Brakes - APPLY HEAVILY

### **PRECAUTIONARY LANDING WITH ENGINE POWER**

1. Pilot and Passenger Seat Backs - MOST UPRIGHT POSITION
2. Seats and Seat Belts - SECURE
3. Airspeed - 65 KIAS
4. Wing Flaps - 20°
5. Selected Field - FLY OVER (noting terrain and obstructions)
6. Wing Flaps - FULL (on final approach)
7. Airspeed - 65 KIAS
8. STBY BATT Switch - OFF
9. MASTER Switch (ALT and BAT) - OFF (when landing assured)
10. Doors - UNLATCH PRIOR TO TOUCHDOWN
11. Touchdown - SLIGHTLY TAIL LOW
12. Mixture Control - IDLE CUTOFF (pull full out)
13. MAGNETOS Switch - OFF
14. Brakes - APPLY HEAVILY

(Continued Next Page)

## **FORCED LANDINGS** (Continued)

### **DITCHING**

1. Radio - TRANSMIT MAYDAY on 121.5 MHz, (give location, intentions and SQUAWK 7700)
2. Heavy Objects (in baggage area) - SECURE OR JETTISON (if possible)
3. Pilot and Passenger Seat Backs - MOST UPRIGHT POSITION
4. Seats and Seat Belts - SECURE
5. Wing Flaps - 20° - FULL
6. Power - ESTABLISH 300 FT/MIN DESCENT AT 55 KIAS

#### **NOTE**

If no power is available, approach at 70 KIAS with Flaps UP or at 65 KIAS with Flaps 10°.

7. Approach - High Winds, Heavy Seas - INTO THE WIND  
Light Winds, Heavy Swells - PARALLEL TO SWELLS
8. Cabin Doors - UNLATCH
9. Touchdown - LEVEL ATTITUDE AT ESTABLISHED RATE OF DESCENT
10. Face - CUSHION AT TOUCHDOWN (with folded coat)
11. ELT - ACTIVATE
12. Airplane - EVACUATE THROUGH CABIN DOORS

#### **NOTE**

If necessary, open window and flood cabin to equalize pressure so doors can be opened.

13. Life Vests and Raft - INFLATE WHEN CLEAR OF AIRPLANE

## FIRES

### DURING START ON GROUND

1. **MAGNETOS Switch - START** (continue cranking to start the engine)

#### IF ENGINE STARTS

2. Power - 1800 RPM (for a few minutes)
3. Engine - SHUTDOWN (inspect for damage)

#### IF ENGINE FAILS TO START

2. Throttle Control - FULL (push full in)
3. Mixture Control - IDLE CUTOFF (pull full out)
4. MAGNETOS Switch - START (continue cranking)
5. FUEL SHUTOFF Valve - OFF (pull full out)
6. FUEL PUMP Switch - OFF
7. MAGNETOS Switch - OFF
8. STBY BATT Switch - OFF
9. MASTER Switch (ALT and BAT) - OFF
10. Engine - SECURE
11. Parking Brake - RELEASE
12. Fire Extinguisher - OBTAIN (have ground attendants obtain if not installed)
13. Airplane - EVACUATE
14. Fire - EXTINGUISH (using fire extinguisher, wool blanket, or dirt)
15. Fire Damage - INSPECT (repair or replace damaged components and/or wiring before conducting another flight)

(Continued Next Page)

## **FIRES** (Continued)

### **ENGINE FIRE IN FLIGHT**

1. **Mixture Control - IDLE CUTOFF (pull full out)**
2. **FUEL SHUTOFF Valve - OFF (pull full out)**
3. **FUEL PUMP Switch - OFF**
4. **MASTER Switch (ALT and BAT) - OFF**
5. Cabin Vents - OPEN (as needed)
6. CABIN HT and CABIN AIR Control Knobs - OFF (push full in) (to avoid drafts)
7. Airspeed - 100 KIAS (If fire is not extinguished, increase glide speed to find an airspeed, within airspeed limitations, which will provide an incombustible mixture)
8. Forced Landing - EXECUTE (refer to EMERGENCY LANDING WITHOUT ENGINE POWER)

### **ELECTRICAL FIRE IN FLIGHT**

1. **STBY BATT Switch - OFF**
2. **MASTER Switch (ALT and BAT) - OFF**
3. **Cabin Vents - CLOSED (to avoid drafts)**
4. **CABIN HT and CABIN AIR Control Knobs - OFF (push full in) (to avoid drafts)**
5. **Fire Extinguisher - ACTIVATE (if available)**
6. **AVIONICS Switch (BUS 1 and BUS 2) - OFF**
7. **All Other Switches (except MAGNETOS switch) - OFF**

### **WARNING**

**AFTER THE FIRE EXTINGUISHER HAS BEEN USED, MAKE SURE THAT THE FIRE IS EXTINGUISHED BEFORE EXTERIOR AIR IS USED TO REMOVE SMOKE FROM THE CABIN.**

8. Cabin Vents - OPEN (when sure that fire is completely extinguished)
9. CABIN HT and CABIN AIR Control Knobs - ON (pull full out) (when sure that fire is completely extinguished)

(Continued Next Page)

## **FIRES** (Continued)

### **ELECTRICAL FIRE IN FLIGHT** (Continued)

**IF FIRE HAS BEEN EXTINGUISHED AND ELECTRICAL POWER IS NECESSARY FOR CONTINUED FLIGHT TO NEAREST SUITABLE AIRPORT OR LANDING AREA**

10. Circuit Breakers - CHECK (for OPEN circuit(s), do not reset)
11. MASTER Switch (ALT and BAT) - ON
12. STBY BATT Switch - ARM
13. AVIONICS Switch (BUS 1) - ON
14. AVIONICS Switch (BUS 2) - ON

### **CABIN FIRE**

1. STBY BATT Switch - OFF
2. MASTER Switch (ALT and BAT) - OFF
3. Cabin Vents - CLOSED (to avoid drafts)
4. CABIN HT and CABIN AIR Control Knobs - OFF (push full in) (to avoid drafts)
5. Fire Extinguisher - ACTIVATE (if available)

#### **WARNING**

**AFTER THE FIRE EXTINGUISHER HAS BEEN USED, MAKE SURE THAT THE FIRE IS EXTINGUISHED BEFORE EXTERIOR AIR IS USED TO REMOVE SMOKE FROM THE CABIN.**

6. Cabin Vents - OPEN (when sure that fire is completely extinguished)
7. CABIN HT and CABIN AIR Control Knobs - ON (pull full out) (when sure that fire is completely extinguished)
8. Land the airplane as soon as possible to inspect for damage.

(Continued Next Page)

## **FIRES** (Continued)

### **WING FIRE**

1. **LAND and TAXI Light Switches - OFF**
2. **NAV Light Switch - OFF**
3. **STROBE Light Switch - OFF**
4. **PITOT HEAT Switch - OFF**

### **NOTE**

Perform a sideslip to keep the flames away from the fuel tank and cabin. Land as soon as possible using flaps only as required for final approach and touchdown.

## ICING

### INADVERTENT ICING ENCOUNTER DURING FLIGHT

1. **PITOT HEAT Switch - ON**
2. Turn back or change altitude (to obtain an outside air temperature that is less conducive to icing)
3. **CABIN HT Control Knob - ON (pull full out)**
4. **Defroster Control Outlets - OPEN (to obtain maximum windshield defroster airflow)**
5. **CABIN AIR Control Knob - ADJUST (to obtain maximum defroster heat and airflow)**
6. Watch for signs of induction air filter icing. A loss of engine RPM could be caused by ice blocking the air intake filter. Adjust the throttle as necessary to hold engine RPM. Adjust mixture as necessary for any change in power settings.
7. Plan a landing at the nearest airport. With an extremely rapid ice build-up, select a suitable off airport landing site.
8. With an ice accumulation of 0.25 inch or more on the wing leading edges, be prepared for significantly higher power requirements, higher approach and stall speeds, and a longer landing roll.
9. Leave wing flaps retracted. With a severe ice build-up on the horizontal tail, the change in wing wake airflow direction caused by wing flap extension could result in a loss of elevator effectiveness.
10. Open left window and, if practical, scrape ice from a portion of the windshield for visibility in the landing approach.
11. Perform a landing approach using a forward slip, if necessary, for improved visibility.
12. Approach at 65 to 75 KIAS depending upon the amount of ice accumulation.
13. Perform landing in level attitude.
14. Missed approaches should be avoided whenever possible because of severely reduced climb capability.

## **STATIC SOURCE BLOCKAGE (ERRONEOUS INSTRUMENT READING SUSPECTED)**

1. **ALT STATIC AIR Valve - ON (pull full out)**
2. Cabin Vents - CLOSED
3. CABIN HT and CABIN AIR Control Knobs - ON (pull full out)
4. Airspeed - Refer to Section 5, Figure 5-1 (Sheet 2) Airspeed Calibration, Alternate Static Source correction chart.

## **EXCESSIVE FUEL VAPOR**

### **FUEL FLOW STABILIZATION PROCEDURES**

**(If flow fluctuations of 1 GPH or more, or power surges occur.)**

1. FUEL PUMP Switch - ON
2. Mixture Control - ADJUST (as necessary for smooth engine operation)
3. Fuel Selector Valve - SELECT OPPOSITE TANK (if vapor symptoms continue)
4. FUEL PUMP Switch - OFF (after fuel flow has stabilized)

## **ABNORMAL LANDINGS**

### **LANDING WITH A FLAT MAIN TIRE**

1. Approach - NORMAL
2. Wing Flaps - FULL
3. Touchdown - GOOD MAIN TIRE FIRST (hold airplane off flat tire as long as possible with aileron control)
4. Directional Control - MAINTAIN (using brake on good wheel as required)

### **LANDING WITH A FLAT NOSE TIRE**

1. Approach - NORMAL
2. Wing Flaps - AS REQUIRED  
85 to 110 KIAS - Flaps UP - 10°  
Below 85 KIAS - Flaps 10° - FULL
3. Touchdown - ON MAINS (hold nosewheel off the ground as long as possible)
4. When nosewheel touches down, maintain full up elevator as airplane slows to stop.

## **ELECTRICAL POWER SUPPLY SYSTEM MALFUNCTIONS**

### **HIGH VOLTS ANNUNCIATOR COMES ON OR M BATT AMPS MORE THAN 40**

1. MASTER Switch (ALT Only) - OFF
2. Electrical Load - REDUCE IMMEDIATELY as follows:
  - a. AVIONICS Switch (BUS 1) - OFF
  - b. PITOT HEAT Switch - OFF
  - c. BEACON Light Switch - OFF
  - d. LAND Light Switch - OFF (use as required for landing)
  - e. TAXI Light Switch - OFF
  - f. NAV Light Switch - OFF
  - g. STROBE Light Switch - OFF
  - h. CABIN PWR 12V Switch - OFF (if installed)

#### **NOTE**

- The main battery supplies electrical power to the main and essential buses until M BUS VOLTS decreases below 20 volts. When M BUS VOLTS falls below 20 volts, the standby battery system will automatically supply electrical power to the essential bus for at least 30 minutes.
- Select COM1 MIC and NAV1 on the audio panel and tune to the active frequency before setting AVIONICS BUS 2 to OFF. If COM2 MIC and NAV2 are selected when AVIONICS BUS 2 is set to OFF, the COM and NAV radios cannot be tuned.

(Continued Next Page)

## **ELECTRICAL POWER SUPPLY SYSTEM MALFUNCTIONS** (Continued)

### **HIGH VOLTS ANNUNCIATOR COMES ON OR M BATT AMPS MORE THAN 40** (Continued)

- i. COM1 and NAV1 - TUNE TO ACTIVE FREQUENCY
- j. COM1 MIC and NAV1 - SELECT (COM2 MIC and NAV2 will be inoperative once AVIONICS BUS 2 is selected to OFF)

#### **NOTE**

When AVIONICS BUS 2 is set to OFF, the following items will not operate:

Autopilot	Audio Panel
COMM 2	NAV 2
Transponder	MFD

- k. AVIONICS Switch (BUS 2) - OFF (KEEP ON if in clouds)
3. Land as soon as practical.

#### **NOTE**

Make sure a successful landing is possible before extending flaps. The flap motor is a large electrical load during operation.

(Continued Next Page)

## **ELECTRICAL POWER SUPPLY SYSTEM MALFUNCTIONS** (Continued)

### **LOW VOLTS ANNUNCIATOR COMES ON BELOW 1000 RPM**

1. Throttle Control - 1000 RPM
2. LOW VOLTS Annunciator - CHECK OFF

### **LOW VOLTS ANNUNCIATOR REMAINS ON AT 1000 RPM**

3. Authorized maintenance personnel must do electrical system inspection prior to next flight.

### **LOW VOLTS ANNUNCIATOR COMES ON OR DOES NOT GO OFF AT HIGHER RPM**

1. MASTER Switch (ALT Only) - OFF
2. ALT FIELD Circuit Breaker - CHECK IN
3. MASTER Switch (ALT and BAT) - ON
4. LOW VOLTS Annunciator - CHECK OFF
5. M BUS VOLTS - CHECK 27.5 V (minimum)
6. M BATT AMPS - CHECK CHARGING (+)

### **IF LOW VOLTS ANNUNCIATOR REMAINS ON**

7. MASTER Switch (ALT Only) - OFF
8. Electrical Load - REDUCE IMMEDIATELY as follows:
  - a. AVIONICS Switch (BUS 1) - OFF
  - b. PITOT HEAT Switch - OFF
  - c. BEACON Light Switch - OFF
  - d. LAND Light Switch - OFF (use as required for landing)
  - e. TAXI Light Switch - OFF
  - f. NAV Light Switch - OFF
  - g. STROBE Light Switch - OFF
  - h. CABIN PWR 12V Switch - OFF (if installed)

(Continued Next Page)

## ELECTRICAL POWER SUPPLY SYSTEM MALFUNCTIONS (Continued)

### IF LOW VOLTS ANNUNCIATOR REMAINS ON (Continued)

#### NOTE

- The main battery supplies electrical power to the main and essential buses until M BUS VOLTS decreases below 20 volts. When M BUS VOLTS falls below 20 volts, the standby battery system will automatically supply electrical power to the essential bus for at least 30 minutes.
- Select COM1 MIC and NAV1 on the audio panel and tune to the active frequency before setting AVIONICS BUS 2 to OFF. If COM2 MIC and NAV2 are selected when AVIONICS BUS 2 is set to OFF, the COM and NAV radios cannot be tuned.
  - i. COM1 and NAV1 - TUNE TO ACTIVE FREQUENCY
  - j. COM1 MIC and NAV1 - SELECT (COM2 MIC and NAV2 will be inoperative once AVIONICS BUS 2 is selected to OFF)

#### NOTE

When AVIONICS BUS 2 is set to OFF, the following items will not operate:

Autopilot	Audio Panel
COMM 2	NAV 2
Transponder	MFD

- k. AVIONICS Switch (BUS 2) - OFF (KEEP ON if in clouds)
9. Land as soon as practical.

#### NOTE

Make sure a successful landing is possible before extending flaps. The flap motor is a large electrical load during operation.

## **AIR DATA SYSTEM FAILURE**

### **RED X - PFD AIRSPEED INDICATOR**

1. ADC/AHRS Circuit Breakers - CHECK IN (ESS BUS and AVN BUS 1). If open, reset (close) circuit breaker. If circuit breaker opens again, do not reset.
2. Standby Airspeed - USE FOR AIRSPEED INFORMATION

### **RED X - PFD ALTITUDE INDICATOR**

1. ADC/AHRS Circuit Breakers - CHECK IN (ESS BUS and AVN BUS 1). If open, reset (close) circuit breaker. If circuit breaker opens again, do not reset.
2. Standby Altimeter - CHECK current barometric pressure SET. USE FOR ALTITUDE INFORMATION.

## **ATTITUDE AND HEADING REFERENCE SYSTEM (AHRS) FAILURE**

### **RED X - PFD ATTITUDE INDICATOR**

1. ADC/AHRS Circuit Breakers - CHECK IN (ESS BUS and AVN BUS 1). If open, reset (close) circuit breaker. If circuit breaker opens again, do not reset.
2. Standby Attitude - USE FOR ATTITUDE INFORMATION

### **RED X - HORIZONTAL SITUATION INDICATOR (HSI)**

1. ADC/AHRS Circuit Breakers - CHECK IN (ESS BUS and AVN BUS 1). If open, reset (close) circuit breaker. If circuit breaker opens again, do not reset.
2. Non-Stabilized Magnetic Compass - USE FOR HEADING INFORMATION

## **AUTOPILOT OR ELECTRIC TRIM FAILURE** (if installed)

### **AP OR PTRM ANNUNCIATOR(S) COME ON**

1. Control Wheel - **GRASP FIRMLY** (regain control of airplane)
2. A/P TRIM DISC Button - **PRESS and HOLD** (throughout recovery)
3. Elevator Trim Control - **ADJUST MANUALLY** (as necessary)
4. AUTO PILOT Circuit Breaker - **OPEN** (pull out)
5. A/P TRIM DISC Button - **RELEASE**

### **WARNING**

**FOLLOWING AN AUTOPILOT, AUTOTRIM OR MANUAL ELECTRIC TRIM SYSTEM MALFUNCTION, DO NOT ENGAGE THE AUTOPILOT UNTIL THE CAUSE OF THE MALFUNCTION HAS BEEN CORRECTED.**

## **VACUUM SYSTEM FAILURE** (if installed)

### **LOW VACUUM ANNUNCIATOR COMES ON**

1. **Vacuum Indicator (VAC) - CHECK EIS ENGINE PAGE (make sure vacuum pointer is in green band limits)**

#### **CAUTION**

IF VACUUM POINTER IS OUT OF THE GREEN BAND DURING FLIGHT OR THE GYRO FLAG IS SHOWN ON THE STANDBY ATTITUDE INDICATOR, THE STANDBY ATTITUDE INDICATOR MUST NOT BE USED FOR ATTITUDE INFORMATION.

## **HIGH CARBON MONOXIDE (CO) LEVEL ADVISORY**

### **CO LVL HIGH ANNUNCIATOR COMES ON**

- 1. CABIN HT Control Knob - OFF (push full in)**
- 2. CABIN AIR Control Knob - ON (pull full out)**
- 3. Cabin Vents - OPEN**
- 4. Cabin Windows - OPEN (163 KIAS maximum windows open speed)**

### **CO LVL HIGH ANNUNCIATOR REMAINS ON**

- 5. Land as soon as possible.**

## **AMPLIFIED EMERGENCY PROCEDURES**

The following Amplified Emergency Procedures provide additional information beyond that in the Emergency Procedures Checklists portion of this section. These procedures also include information not readily adaptable to a checklist format, and material to which a pilot could not be expected to refer in resolution of a specific emergency. This information should be reviewed in detail prior to flying the airplane, as well as reviewed on a regular basis to keep pilot's knowledge of procedures fresh.

### **ENGINE FAILURE**

If an engine failure occurs during the takeoff roll, stop the airplane on the remaining runway. Those extra items on the checklist will provide added safety after a failure of this type.

If an engine failure occurs immediately after takeoff, in most cases, the landing should be planned straight ahead with only small changes in direction to avoid obstructions. Altitude and airspeed are seldom sufficient to execute the 180° gliding turn necessary to return to the runway. The checklist procedures assume that adequate time exists to secure the fuel and ignition systems prior to touchdown.

After an engine failure in flight, the most important task is to continue flying the airplane. The best glide speed, as shown in Figure 3-1, should be established as quickly as possible. While gliding toward a suitable landing area, an effort should be made to identify the cause of the failure. If time permits, an engine restart should be attempted as shown in the checklist. If the engine cannot be restarted, a forced landing without power must be completed.

### MAXIMUM GLIDE

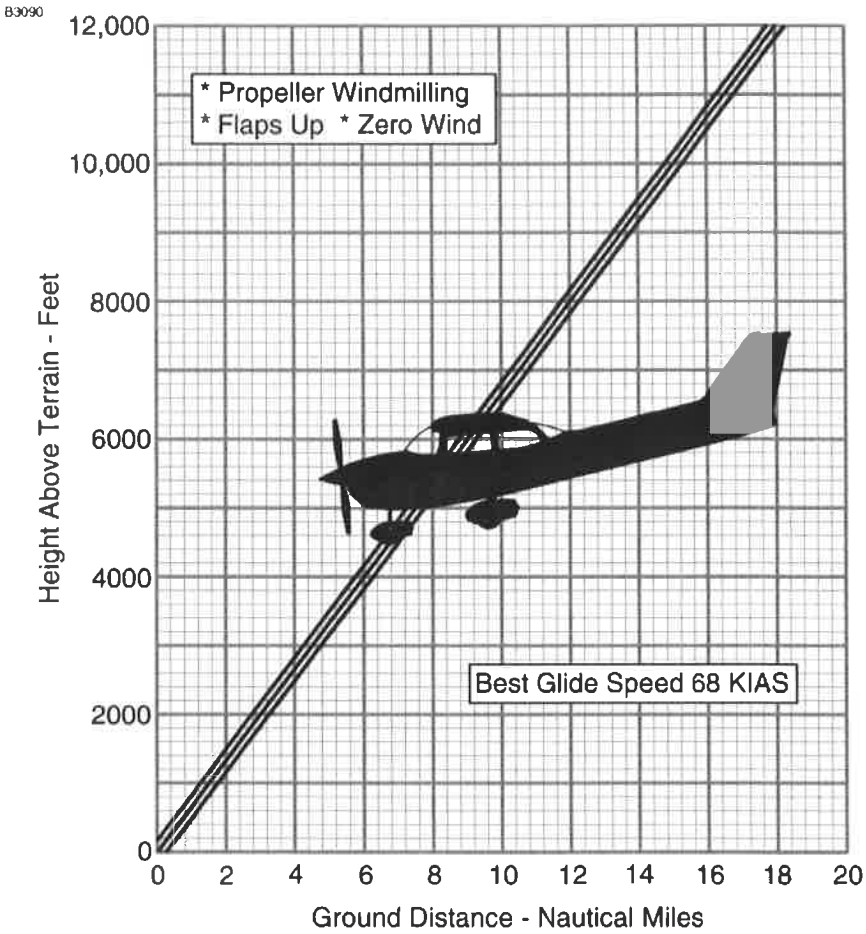

Figure 3-1

## **FORCED LANDINGS**

If all attempts to restart the engine fail and a forced landing is imminent, select a suitable field and prepare for the landing as discussed under the Emergency Landing Without Engine Power checklist. Transmit Mayday message on 121.5 MHz giving location, intentions and squawk 7700.

Before attempting an off airport landing with engine power available, one should fly over the landing area at a safe, but low altitude, to inspect the terrain for obstructions and surface conditions, proceeding as discussed in the Precautionary Landing With Engine Power checklist.

Prepare for ditching by securing or jettisoning heavy objects located in the baggage area and collect folded coats for protection of occupants' face at touchdown. Transmit Mayday messages on 121.5 MHz giving location, intentions and squawk 7700. Avoid a landing flare because of the difficulty in judging height over a water surface. The checklist assumes the availability of power to make a precautionary water landing. If power is not available, use of the airspeeds noted with minimum flap extension will provide a more favorable attitude for a power off ditching.

In a forced landing situation, do not turn off the MASTER switch, AVIONICS switch or STBY BATT switch until a landing is assured. Premature deactivation of the switches will disable all airplane electrical systems.

Before completing a forced landing, especially in remote and mountainous areas, activate the ELT by setting the cockpit-mounted switch to the ON position. For complete information on ELT operation, refer to Section 9, Supplements.

## LANDING WITHOUT ELEVATOR CONTROL

Trim for horizontal flight with an airspeed of approximately 65 KIAS and flaps set to 20° by using throttle and elevator trim controls. Then **do not change the elevator trim control setting**; control the glide angle by adjusting power.

During the landing flare (round-out), the nose will come down when power is reduced and the airplane may touch down on the nosewheel before the main wheels. When in the flare, the elevator trim control should be adjusted toward the full nose up position and the power adjusted at the same time so that the airplane will rotate to a horizontal attitude for touchdown. Close the throttle at touchdown.

## FIRES

Improper starting procedures involving the excessive use of auxiliary fuel pump operation can cause engine flooding and subsequent collection of fuel on the parking ramp as the excess fuel drains overboard from the intake manifolds. This is sometimes experienced in difficult starts in cold weather where engine preheat service is not available. If this occurs, the airplane should be pushed away from the fuel puddle before another engine start is attempted. Otherwise, there is a possibility of raw fuel accumulations in the exhaust system igniting during an engine start, causing a long flame from the tailpipe, and possibly igniting the collected fuel on the pavement. If a fire occurs, proceed according to the checklist.

Although engine fires are extremely rare in flight, if a fire is encountered, the steps of the appropriate checklist should be followed. After completion of the checklist procedure, execute a forced landing. Do not attempt to restart the engine.

The first sign of an electrical fire is usually the smell of burning insulation. The checklist procedure should result in the elimination of the fire.

## EMERGENCY OPERATION IN CLOUDS

If the engine-driven vacuum pump (if installed) fails in flight, the standby attitude indicator will not be accurate. The pilot must then rely on the attitude and heading information (from the AHRS) shown on the PFD indicators. With valid HDG or GPS/NAV inputs, autopilot operation will not be affected.

If the Standby Flight Instrument (GI 275) is installed, and fails in flight, the unit's attitude indicator will not be accurate. The pilot must then rely on the attitude and heading information (from the AHRS) shown on the PFD indicators. With valid HDG or GPS/NAV inputs, autopilot operation will not be affected.

If the AHRS unit fails in flight (red X's shown through the PFD attitude and heading indicators), the pilot must rely on the standby attitude and non-stabilized magnetic compass for attitude and heading information.

The autopilot will not operate if the PFD AHRS unit fails. The pilot must manually fly the airplane without AHRS input. Refer to Section 7, Airplane and Systems Description, for additional details on autopilot operations.

The following instructions assume that the pilot is not very proficient at instrument flying and is flying the airplane without the autopilot engaged.

### EXECUTING A 180° TURN IN CLOUDS (AHRS FAILED)

Upon inadvertently entering the clouds, an immediate turn to reverse course and return to VFR conditions should be made as follows:

#### AHRS FAILURE

1. Note the non-stabilized magnetic compass heading.
2. Using the standby attitude, initiate a 15° bank left turn. Keep feet off rudder pedals. Maintain altitude and 15° bank angle. Continue the turn for 60 seconds, then roll back to level flight.
3. When the compass card becomes sufficiently stable, check the accuracy of the turn by verifying that the compass heading approximates the reciprocal of the original heading.
4. If necessary, adjust the heading by keeping the wings level and using the rudder to make skidding turns (the compass will read more accurately) to complete the course reversal.

(Continued Next Page)

## **EMERGENCY OPERATION IN CLOUDS** (Continued)

5. Maintain altitude and airspeed by cautious application of elevator control. Keep the roll pointer and index aligned and steer only with rudder.

## **EMERGENCY DESCENT THROUGH CLOUDS (AHRS FAILED)**

When returning to VFR flight after a 180° turn is not practical, a descent through the clouds to VFR conditions below may be appropriate. If possible, obtain an ATC clearance for an emergency descent through the clouds.

### **AHRS FAILURE**

Choose an easterly or westerly heading to minimize non-stabilized magnetic compass card sensitivity. Occasionally check the compass heading and make minor corrections to hold an approximate course. The autopilot will not operate if the AHRS unit fails. The pilot must manually fly the airplane without AHRS input.

Before descending into the clouds, prepare for a stabilized descent as follows:

1. Apply full rich mixture.
2. Turn pitot heat on.
3. Set power for a 500 to 800 feet per minute rate of descent.
4. Set the elevator trim for a stabilized descent at 80 KIAS.
5. Use the standby attitude to keep wings level.
6. Check trend of compass card movement and make cautious corrections with rudder to stop the turn.
7. Upon breaking out of clouds, resume normal cruising flight.

(Continued Next Page)

## **EMERGENCY OPERATION IN CLOUDS (Continued)**

### **RECOVERY FROM SPIRAL DIVE IN THE CLOUDS (AHRS FAILED)**

#### **AHRS FAILURE**

If a spiral is entered while in the clouds, continue as follows:

1. Retard throttle to idle position.
2. Remove feet from rudder pedals.
3. Stop turn by carefully leveling the wings using aileron control.
4. Cautiously apply elevator back pressure to slowly reduce the airspeed to 80 KIAS.
5. Adjust the elevator trim control to maintain an 80 KIAS glide.
6. Use aileron control to maintain wings level (keep roll pointer and index aligned) and constant heading.
7. Resume Emergency Descent Through The Clouds procedure.
8. Upon breaking out of clouds, resume normal cruising flight.

### **INADVERTENT FLIGHT INTO ICING CONDITIONS**

Flight into icing conditions is prohibited and extremely dangerous. An inadvertent encounter with these conditions can be resolved using the checklist procedures. The best action is to turn back or change altitude to escape icing conditions. Set the PITOT HEAT switch to the ON position until safely out of icing conditions.

During these encounters, an unexplained loss of engine power could be caused by ice blocking the air intake filter or in extremely rare instances ice completely blocking the fuel injection air reference tubes. In either case, the throttle should be positioned to obtain maximum RPM (in some instances, the throttle may need to be retarded for maximum power). The mixture should then be adjusted, as required, to obtain maximum RPM.

## STATIC SOURCE BLOCKED

If erroneous readings of the static source instruments (airspeed, altimeter and vertical speed) are suspected, the alternate static source air valve (ALT STATIC AIR) should be pulled ON, thereby supplying static pressure to these instruments from the cabin.

When the ALT STATIC AIR valve is ON, the maximum airspeed variation from normal static source operation is 11 knots and the maximum altimeter variation is 50 feet with all windows closed. Refer to Section 5, Figure 5-1 (Sheet 2), Airspeed Calibration - Alternate Static Source correction tables for additional details.

## SPINS

Should an inadvertent spin occur, the following recovery procedure should be used:

1. RETARD THROTTLE TO IDLE POSITION.
2. PLACE AILERONS IN NEUTRAL POSITION.
3. APPLY AND **HOLD** FULL RUDDER OPPOSITE TO THE DIRECTION OF ROTATION.
4. **JUST AFTER** THE RUDDER REACHES THE STOP, MOVE THE CONTROL WHEEL **BRISKLY** FORWARD FAR ENOUGH TO BREAK THE STALL. Full down elevator may be required at aft center of gravity loadings to assure optimum recoveries.
5. **HOLD** THESE CONTROL INPUTS UNTIL ROTATION STOPS. Premature relaxation of the control inputs may extend the recovery.
6. AS ROTATION STOPS, NEUTRALIZE RUDDER, AND MAKE A SMOOTH RECOVERY FROM THE RESULTING DIVE.

### NOTE

If the rate of the spin makes determining the direction of rotation difficult, the magenta turn rate indicator at the top of the HSI compass card will show the rate and direction of the turn. The HSI compass card will rotate in the opposite direction. Hold opposite rudder to the turn vector direction.

For additional information on spins and spin recovery, see the discussion under SPINS in Normal Procedures, Section 4.

## **ROUGH ENGINE OPERATION OR LOSS OF POWER**

### **SPARK PLUG FOULING**

A slight engine roughness in flight may be caused by one or more spark plugs becoming fouled by carbon or lead deposits. This may be verified by turning the MAGNETOS switch momentarily from BOTH to either L or R position. An obvious power loss in single magneto operation is evidence of spark plug or magneto trouble. Since spark plugs are the more likely cause, lean the mixture to the recommended lean setting for cruising flight. If the problem does not clear up in several minutes, determine if a richer mixture setting will produce smoother operation. If not, proceed to the nearest airport for repairs using the BOTH position of the MAGNETOS switch unless extreme roughness makes the use of a single MAGNETO position necessary.

### **MAGNETO MALFUNCTION**

Sudden engine roughness or misfiring is usually a sign of a magneto problem. Changing the MAGNETOS switch from BOTH to the L and R switch positions will identify which magneto is malfunctioning. Select different power settings and enrichen the mixture to determine if continued operation on BOTH magnetos is possible. If not, change to the good magneto and continue to the nearest airport for repairs.

### **IDLE POWER ENGINE ROUGHNESS**

**(As Required by AD 2001-06-17, Paragraph (d)(3))**

An excessively rich idle fuel flow may cause low speed engine roughness during flight. During most in-flight low engine speeds (power off stalls, approach to landing, etc.), the mixture control is normally in the full-rich position. However, to improve engine roughness (caused by an improperly adjusted fuel servo) during low engine speeds while in flight, you should rotate the vernier mixture control (leaning of fuel mixture). You may also have to lean the fuel mixture if this low engine speed results in power loss and you need to restart the engine during flight. In all cases, you should land the airplane at the nearest airport for repairs if low speed engine roughness requires you to adjust the fuel mixture control to improve engine operation.

(Continued Next Page)

## ROUGH ENGINE OPERATION OR LOSS OF POWER

(Continued)

### ENGINE-DRIVEN FUEL PUMP FAILURE

Failure of the engine-driven fuel pump will be shown by a sudden reduction in the fuel flow indication (FFLOW GPH) **immediately before a loss of power** while operating from a fuel tank containing adequate fuel.

If the engine-driven fuel pump fails, immediately set the FUEL PUMP switch to the ON position to restore the engine power. The flight should be terminated as soon as practical and the engine-driven fuel pump repaired.

### EXCESSIVE FUEL VAPOR

Fuel vapor in the fuel injection system is most likely to occur on the ground, typically during prolonged taxi operations, when operating at higher altitudes and/or in unusually warm temperatures.

Excessive fuel vapor accumulation is shown by fuel flow indicator (FFLOW GPH) fluctuations greater than 1 GPH. This condition, with leaner mixtures or with larger fluctuations, can result in power surges, and if not corrected, may cause power loss.

To slow vapor formation and stabilize fuel flow on the ground or in the air, set the FUEL PUMP switch to the ON position and adjust the mixture as required for smooth engine operation. If vapor symptoms continue, select the opposite fuel tank. When fuel flow stabilizes, set the FUEL PUMP switch to the OFF position and adjust the mixture as desired.

(Continued Next Page)

## **ROUGH ENGINE OPERATION OR LOSS OF POWER**

(Continued)

### **LOW OIL PRESSURE**

If the low oil pressure annunciator (OIL PRESS) comes on, check the oil pressure indicator (OIL PRES on ENGINE page or OIL PSI on SYSTEM page) to confirm low oil pressure condition. If oil temperature (OIL TEMP on ENGINE page or OIL °F on SYSTEM page) remains normal, it is possible that the oil pressure sending unit or relief valve is malfunctioning. Land at the nearest airport to determine the source of the problem.

If a total loss of oil pressure and a rise in oil temperature occur at about the same time, it could mean that the engine is about to fail. Reduce power immediately and select a field suitable for a forced landing. Use only the minimum power necessary to reach the landing site.

## **ELECTRICAL POWER SUPPLY SYSTEM MALFUNCTIONS**

Malfunctions in the electrical power supply system can be detected through regular monitoring of the main battery ammeter (M BATT AMPS) and the main electrical bus voltmeter (M BUS VOLTS); however, the cause of these malfunctions is usually difficult to determine. A broken alternator drive belt, too much wear on the alternator brushes, or an error in wiring is most likely the cause of alternator failures, although other factors could cause the problem. A defective Alternator Control Unit (ACU) can also cause malfunctions. Problems of this nature constitute an electrical emergency and should be dealt with immediately. Electrical power malfunctions usually fall into two categories: excessive rate of charge and insufficient rate of charge. The following paragraphs describe the recommended remedy for each situation.

### **EXCESSIVE RATE OF CHARGE**

After engine starting and heavy electrical usage at low engine speeds (such as extended taxiing), the battery condition will be low enough to accept above normal charging during the initial part of a flight. However, after thirty minutes of cruising flight, the main battery ammeter (M BATT AMPS) should be indicating less than 5 amps of charging (+) current. If the charging current remains above this value on a long flight, the battery electrolyte could overheat and evaporate.

Electronic components in the electrical system can be adversely affected by higher than normal voltage. The ACU includes an overvoltage sensor circuit which will automatically disconnect the alternator if the charge voltage increases to more than approximately 31.75 volts. If the overvoltage sensor circuit does not operate correctly, as shown by voltage more than 31.75 volts on the main battery bus voltmeter, the MASTER switch ALT section should be set to the OFF position. Unnecessary electrical equipment should be de-energized and the flight terminated as soon as practical.

(Continued Next Page)

## **ELECTRICAL POWER SUPPLY SYSTEM MALFUNCTIONS** (Continued)

### **INSUFFICIENT RATE OF CHARGE**

When the overvoltage sensor circuit, or other fault, opens the alternator (ALT FIELD) circuit breaker and de-energizes the alternator, a discharge (-) current will be shown on the main battery ammeter and the low voltage annunciator (LOW VOLTS) will come on. The ACU can de-energize the alternator due to minor disturbances in the electrical system, resulting in a nuisance opening of the ALT FIELD circuit breaker. If this happens, an attempt should be made to energize the alternator system.

To energize the alternator system

1. MASTER Switch (ALT Only) - OFF
2. ALT FIELD Circuit Breaker - CHECK IN
3. MASTER Switch (ALT Only) - ON

If the problem was a minor ACU disturbance in the electrical system, normal main battery charging will start. A charge (+) current will be shown on the main battery ammeter and the LOW VOLTS annunciator will go off.

If the LOW VOLTS annunciator comes on again, there is an alternator system problem. Do not repeat steps to energize the alternator system. The electrical load on the battery must be minimized (by de-energizing nonessential electrical equipment and avionics) because the battery can supply the electrical system for only a short time. Reduce electrical load as soon as possible to extend the life of the battery for landing. Land as soon as practical.

(Continued Next Page)

## **ELECTRICAL POWER SUPPLY SYSTEM MALFUNCTIONS (Continued)**

### **INSUFFICIENT RATE OF CHARGE (Continued)**

Main battery life can be extended by setting the MASTER switch (ALT and BAT) to OFF and operating the equipment on the ESS BUS from the standby battery. The standby battery is only capable of providing power for systems on the essential bus and cannot provide power for transponder (XPDR) operation. Main battery life should be extended, when practical, for possible later operation of the wing flaps and use of the landing light (at night).

#### **NOTE**

The LOW VOLTS annunciator can come on when the engine is operated at low RPM with a high electrical load. The LOW VOLTS annunciator will usually go off when the engine is operated at higher RPM for greater alternator system output. Make sure that the M BATT AMPS indication shows positive (+) current at the higher RPM.

## **HIGH CARBON MONOXIDE (CO) LEVEL ANNUNCIATION**

Carbon monoxide (CO) is a colorless, odorless, tasteless product of an internal combustion engine and is always present in exhaust fumes. Even minute quantities of carbon monoxide breathed over a long period of time may lead to dire consequences. The symptoms of carbon monoxide poisoning are difficult to detect by the person affected and may include blurred thinking, a feeling of uneasiness, dizziness, headache, and loss of consciousness.

The cabin heater system operates by allowing ambient air to flow through an exhaust shroud where it is heated before being ducted into the cabin. If an exhaust leak, caused by a crack in the exhaust pipe, occurs in the area surrounded by this shroud it would allow exhaust fumes to mix with the heated ambient air being ducted into the cabin. Therefore, if anyone in the cabin smells exhaust fumes, experiences any of the symptoms mentioned above, or the CO LVL HIGH warning annunciation comes on when using the cabin heater, immediately turn off the cabin heater and preform the emergency items for High Carbon Monoxide (CO) Level Advisory.

When the CO detection system senses a CO level of 50 parts per million (PPM) by volume or greater, the alarm turns on a flashing warning annunciation CO LVL HIGH in the annunciation window on the PFD with a continuous tone until the PFD softkey below WARNING is pushed. It then remains on steady until the CO level drops below 50 PPM and automatically resets the alarm.

## **OTHER EMERGENCIES**

### **WINDSHIELD DAMAGE**

If a bird strike or other incident should damage the windshield in flight to the point of creating an opening, a significant loss in performance may be expected. This loss may be minimized in some cases (depending on amount of damage, altitude, etc.) by opening the side windows while the airplane is maneuvered for a landing at the nearest airport. If airplane performance or other adverse conditions prevent landing at an airport, prepare for an off airport landing in accordance with the Precautionary Landing With Engine Power or Ditching checklists.



## NORMAL PROCEDURES

### TABLE OF CONTENTS

	Page
Introduction .....	4-3
Airspeeds For Normal Operation .....	4-3
<b>NORMAL PROCEDURES</b> .....	<b>4-4</b>
Preflight Inspection .....	4-4
Cabin .....	4-5
Empennage .....	4-6
Right Wing Trailing Edge .....	4-6
Right Wing .....	4-7
Nose .....	4-8
Left Wing .....	4-9
Left Wing Leading Edge .....	4-10
Left Wing Trailing Edge .....	4-10
Before Starting Engine .....	4-11
Starting Engine (With Battery) .....	4-12
Starting Engine (With External Power) .....	4-13
Before Takeoff .....	4-15
Takeoff .....	4-18
Normal Takeoff .....	4-18
Short Field Takeoff .....	4-18
Enroute Climb .....	4-19
Cruise .....	4-19
Descent .....	4-20
Before Landing .....	4-21
Landing .....	4-21
Normal Landing .....	4-21
Short Field Landing .....	4-21
Balked Landing .....	4-22
After Landing .....	4-22
Securing Airplane .....	4-22

(Continued Next Page)

## TABLE OF CONTENTS (Continued)

	Page
<b>AMPLIFIED NORMAL PROCEDURES</b> .....	4-23
Preflight Inspection .....	4-23
Starting Engine .....	4-25
Recommended Starter Duty Cycle .....	4-26
Leaning For Ground Operations .....	4-26
Fuel Vapor Procedures .....	4-27
Taxiing .....	4-28
Before Takeoff .....	4-30
Warm Up .....	4-30
Magneto Check .....	4-30
Alternator Check .....	4-30
Elevator Trim .....	4-31
Landing/Taxi Lights .....	4-31
Takeoff .....	4-31
Power Check .....	4-31
Wing Flap Settings .....	4-32
Crosswind Takeoff .....	4-32
Enroute Climb .....	4-33
Cruise .....	4-34
Leaning Using Exhaust Gas Temperature (EGT) .....	4-36
Fuel Savings Procedures For Flight Training Operations .....	4-39
Stalls .....	4-40
Spins .....	4-40
Landing .....	4-43
Normal Landing .....	4-43
Short Field Landing .....	4-43
Crosswind Landing .....	4-44
Balked Landing .....	4-44
Cold Weather Operations .....	4-45
Starting .....	4-46
Winterization Kit .....	4-47
Hot Weather Operations .....	4-48
Noise Characteristics .....	4-48

## INTRODUCTION

Section 4 provides procedures and amplified instructions for normal operations using standard equipment. Normal procedures associated with optional systems can be found in Section 9, Supplements.

## AIRSPEEDS FOR NORMAL OPERATION

Unless otherwise noted, the following speeds are based on a maximum weight of 2550 pounds and may be used for any lesser weight.

### TAKEOFF

Normal Climb . . . . .	75 - 85 KIAS
Short Field Takeoff, Flaps 10°, Speed at 50 Feet . . . . .	56 KIAS

### ENROUTE CLIMB, FLAPS UP

Normal, Sea Level. . . . .	75 - 85 KIAS
Normal, 10,000 Feet . . . . .	70 - 80 KIAS
Best Rate of Climb, Sea Level . . . . .	74 KIAS
Best Rate of Climb, 10,000 Feet . . . . .	72 KIAS
Best Angle of Climb, Sea Level. . . . .	62 KIAS
Best Angle of Climb, 10,000 Feet . . . . .	67 KIAS

### LANDING APPROACH

Normal Approach, Flaps UP . . . . .	65 - 75 KIAS
Normal Approach, Flaps FULL . . . . .	60 - 70 KIAS
Short Field Approach, Flaps FULL . . . . .	61 KIAS

### BALKED LANDING

Maximum Power, Flaps 20° . . . . .	60 KIAS
------------------------------------	---------

### MAXIMUM RECOMMENDED TURBULENT AIR PENETRATION SPEED

2550 POUNDS . . . . .	105 KIAS
2200 POUNDS . . . . .	98 KIAS
1900 POUNDS . . . . .	90 KIAS

### MAXIMUM DEMONSTRATED CROSSWIND VELOCITY

Takeoff, Flaps UP . . . . .	20 KNOTS
Takeoff, Flaps 10° . . . . .	20 KNOTS
Landing, Flaps 10° . . . . .	20 KNOTS
Landing, Flaps FULL. . . . .	15 KNOTS

## NORMAL PROCEDURES PREFLIGHT INSPECTION

B3091

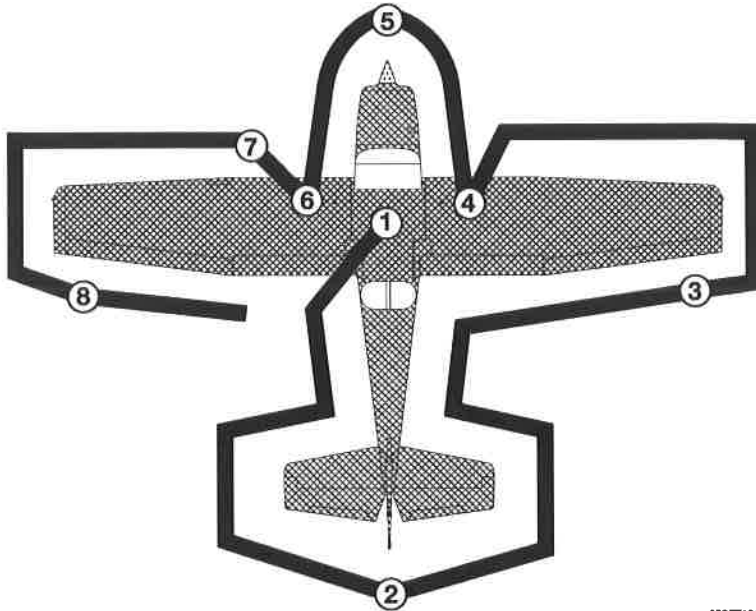

0585T1019

### NOTE

Visually check airplane for general condition during walk-around inspection. Airplane should be parked in a normal ground attitude, refer to Figure 1-1, to make sure that fuel drain valves allow for accurate sampling. Use of the refueling steps and assist handles will simplify access to the upper wing surfaces for visual checks and refueling operations. In cold weather, remove even small accumulations of frost, ice or snow from wing, tail and control surfaces. Also, make sure that control surfaces contain no internal accumulations of ice or debris. Prior to flight, check that pitot heater is warm to touch within 30 seconds with battery and pitot heat switches on. If a night flight is planned, check operation of all lights, verify all LED landing/taxi light bulbs are operational (if installed) and make sure a flashlight is available.

Figure 4-1

## **PREFLIGHT INSPECTION** (Continued)

### **① CABIN**

1. Pitot Tube Cover - REMOVE (check for pitot blockage)
2. Pilot's Operating Handbook - ACCESSIBLE TO PILOT
3. Garmin G1000 Cockpit Reference Guide - ACCESSIBLE TO PILOT
4. Airplane Weight and Balance - CHECKED
5. Parking Brake - SET
6. Control Wheel Lock - REMOVE

### **WARNING**

**WHEN THE MASTER SWITCH IS ON, USING AN EXTERNAL POWER SOURCE, OR MANUALLY ROTATING THE PROPELLER, TREAT THE PROPELLER AS IF THE MAGNETOS SWITCH WERE ON. DO NOT STAND, NOR ALLOW ANYONE ELSE TO STAND, WITHIN THE ARC OF THE PROPELLER SINCE A LOOSE OR BROKEN WIRE, OR A COMPONENT MALFUNCTION, COULD CAUSE THE ENGINE TO START.**

7. MAGNETOS Switch - OFF
8. AVIONICS Switch (BUS 1 and BUS 2) - OFF
9. MASTER Switch (ALT and BAT) - ON
10. Primary Flight Display (PFD) - CHECK (verify PFD is ON)
11. FUEL QTY (L and R) - CHECK
12. LOW FUEL L and LOW FUEL R Annunciators - CHECK (verify annunciators are not shown on PFD)
13. OIL PRESSURE Annunciator - CHECK (verify annunciator is shown)
14. LOW VACUUM Annunciator - CHECK (verify annunciator is shown) (if installed)
15. AVIONICS Switch (BUS 1) - ON
16. Forward Avionics Fan - CHECK (verify fan is heard)

(Continued Next Page)

## **PREFLIGHT INSPECTION** (Continued)

### **① CABIN** (Continued)

17. AVIONICS Switch (BUS 1) - OFF
18. AVIONICS Switch (BUS 2) - ON
19. Aft Avionics Fan - CHECK (verify fan is heard)
20. AVIONICS Switch (BUS 2) - OFF
21. PITOT HEAT Switch - ON (carefully check that pitot tube is warm to the touch within 30 seconds)
22. PITOT HEAT Switch - OFF
23. LOW VOLTS Annunciator - CHECK (verify annunciator is shown)
24. MASTER Switch (ALT and BAT) - OFF
25. Elevator Trim Control - TAKEOFF position
26. FUEL SELECTOR Valve - BOTH
27. ALT STATIC AIR Valve - OFF (push full in)
28. Fire Extinguisher - CHECK (verify gage pointer in green arc)

### **② EMPENNAGE**

1. Baggage Compartment Door - CHECK (lock with key)
2. Rudder Gust Lock - REMOVE (if installed)
3. Tail Tiedown - DISCONNECT
4. Control Surfaces - CHECK (freedom of movement and security)
5. Elevator Trim Tab - CHECK (security)
6. Antennas - CHECK (security of attachment and general condition)

### **③ RIGHT WING Trailing Edge**

1. Flap - CHECK (security and condition)
2. Aileron - CHECK (freedom of movement and security)

(Continued Next Page)

## **PREFLIGHT INSPECTION** (Continued)

### **④ RIGHT WING**

1. Landing/Taxi Light(s) - CHECK (condition and cleanliness of cover) (If installed)
2. Wing Tiedown - DISCONNECT
3. Main Wheel Tire - CHECK (proper inflation and general condition (weather checks, tread depth and wear, etc.))
4. Fuel Tank Sump Quick Drain Valves - DRAIN

Drain at least a cupful of fuel (using sampler cup) from each sump location to check for water, sediment, and proper fuel grade before each flight and after each refueling. If water is observed, take further samples until clear and then gently rock wings and lower tail to the ground to move any additional contaminants to the sampling points. Take repeated samples from **all** fuel drain points until **all** contamination has been removed. If contaminants are still present, refer to WARNING below and do not fly airplane.

### **NOTE**

Collect all sampled fuel in a safe container. Dispose of the sampled fuel so that it does not cause a nuisance, hazard or damage to the environment.

### **WARNING**

**IF, AFTER REPEATED SAMPLING, EVIDENCE OF CONTAMINATION STILL EXISTS, THE AIRPLANE SHOULD NOT BE FLOWN. TANKS SHOULD BE DRAINED AND SYSTEM PURGED BY QUALIFIED MAINTENANCE PERSONNEL. ALL EVIDENCE OF CONTAMINATION MUST BE REMOVED BEFORE FURTHER FLIGHT.**

5. Fuel Quantity - CHECK VISUALLY (for desired level)
6. Fuel Filler Cap - SECURE and VENT CLEAR

(Continued Next Page)

## **PREFLIGHT INSPECTION** (Continued)

### **⑤ NOSE**

1. Fuel Strainer Quick Drain Valve (located on bottom of fuselage) - DRAIN

Drain at least a cupful of fuel (using sampler cup) from valve to check for water, sediment, and proper fuel grade before each flight and after each refueling. If water is observed, take further samples until clear and then gently rock wings and lower tail to the ground to move any additional contaminants to the sampling points. Take repeated samples from **all** fuel drain points, including the fuel reservoir and fuel selector, until **all** contamination has been removed. If contaminants are still present, refer to **WARNING** below and do not fly the airplane.

#### **NOTE**

Collect all sampled fuel in a safe container. Dispose of the sampled fuel so that it does not cause a nuisance, hazard, or damage to the environment.

#### **WARNING**

**IF, AFTER REPEATED SAMPLING, EVIDENCE OF CONTAMINATION STILL EXISTS, THE AIRPLANE SHOULD NOT BE FLOWN. TANKS SHOULD BE DRAINED AND SYSTEM PURGED BY QUALIFIED MAINTENANCE PERSONNEL. ALL EVIDENCE OF CONTAMINATION MUST BE REMOVED BEFORE FURTHER FLIGHT.**

2. Engine Oil Dipstick/Filler Cap:
  - a. Oil level - CHECK
  - b. Dipstick/filler cap - SECURE

#### **NOTE**

**Do not operate with less than 5 quarts.** Fill to 8 quarts for extended flight.

3. Engine Cooling Air Inlets - CHECK (clear of obstructions)
4. Propeller and Spinner - CHECK (for nicks and security)
5. Air Filter - CHECK (for restrictions by dust or other foreign matter)

(Continued Next Page)

## **PREFLIGHT INSPECTION** (Continued)

### **⑤ NOSE** (Continued)

6. Nosewheel Strut and Tire - CHECK (proper inflation of strut and general condition of tire (weather checks, tread depth and wear, etc.))
7. Static Source Opening (left side of fuselage) - CHECK (verify opening is clear)

### **⑥ LEFT WING**

1. Fuel Quantity - CHECK VISUALLY (for desired level)
2. Fuel Filler Cap - SECURE and VENT CLEAR
3. Fuel Tank Sump Quick Drain Valves - DRAIN

Drain at least a cupful of fuel (using sampler cup) from each sump location to check for water, sediment, and proper fuel grade before each flight and after each refueling. If water is observed, take further samples until clear and then gently rock wings and lower tail to the ground to move any additional contaminants to the sampling points. Take repeated samples from **all** fuel drain points until **all** contamination has been removed. If contaminants are still present, refer to WARNING below and do not fly airplane.

#### **NOTE**

Collect all sampled fuel in a safe container. Dispose of the sampled fuel so that it does not cause a nuisance, hazard, or damage to the environment.

#### **WARNING**

**IF, AFTER REPEATED SAMPLING, EVIDENCE OF CONTAMINATION STILL EXISTS, THE AIRPLANE SHOULD NOT BE FLOWN. TANKS SHOULD BE DRAINED AND SYSTEM PURGED BY QUALIFIED MAINTENANCE PERSONNEL. ALL EVIDENCE OF CONTAMINATION MUST BE REMOVED BEFORE FURTHER FLIGHT.**

4. Main Wheel Tire - CHECK (proper inflation and general condition (weather checks, tread depth and wear, etc.))

(Continued Next Page)

## **PREFLIGHT INSPECTION** (Continued)

### **⑦ LEFT WING Leading Edge**

1. Fuel Tank Vent Opening - CHECK (blockage)
2. Stall Warning Opening - CHECK (blockage)

#### **NOTE**

To check the system, place a clean handkerchief over the vent opening and apply suction; a sound from the warning horn will confirm system operation.

3. Wing Tiedown - DISCONNECT
4. Landing/Taxi Light(s) - CHECK (condition and cleanliness of cover)

### **⑧ LEFT WING Trailing Edge**

1. Aileron - CHECK (freedom of movement and security)
2. Flap - CHECK (security and condition)

## **BEFORE STARTING ENGINE**

1. Preflight Inspection - COMPLETE
2. Passenger Briefing - COMPLETE
3. Seats and Seat Belts - ADJUST and LOCK (verify inertia reel locking)
4. Brakes - TEST and SET
5. Circuit Breakers - CHECK IN
6. Electrical Equipment - OFF
7. AVIONICS Switch (BUS 1 and BUS 2) - OFF

### **CAUTION**

THE AVIONICS SWITCH (BUS 1 AND BUS 2) MUST BE OFF DURING ENGINE START TO PREVENT POSSIBLE DAMAGE TO AVIONICS.

8. FUEL SELECTOR Valve - BOTH
9. FUEL SHUTOFF Valve - ON (push full in)

## STARTING ENGINE (With Battery)

1. Throttle Control - OPEN 1/4 INCH
2. Mixture Control - IDLE CUTOFF (pull full out)
3. STBY BATT Switch:
  - a. TEST - (hold for 10 seconds, verify that green TEST lamp does not go off)
  - b. ARM - (verify that PFD comes on)
4. Engine Indicating System - CHECK PARAMETERS (verify no red X's through ENGINE page indicators)
5. BUS E Volts - CHECK (verify 24 VOLTS minimum shown)
6. M BUS Volts - CHECK (verify 1.5 VOLTS or less shown)
7. BATT S Amps - CHECK (verify discharge shown (negative))
8. STBY BATT Annunciator - CHECK (verify annunciator is shown)
9. Propeller Area - CLEAR (verify that all people and equipment are at a safe distance from the propeller)
10. MASTER Switch (ALT and BAT) - ON
11. BEACON Light Switch - ON

### NOTE

If engine is warm, omit priming procedure steps 12 thru 14 below.

12. FUEL PUMP Switch - ON
13. Mixture Control - SET to FULL RICH (full forward) until stable fuel flow is indicated (approximately 3 to 5 seconds), then set to IDLE CUTOFF (full aft) position.
14. FUEL PUMP Switch - OFF
15. MAGNETOS Switch - START (release when engine starts)
16. Mixture Control - ADVANCE SMOOTHLY TO RICH (when engine starts)

### NOTE

If the engine is primed too much (flooded), place the mixture control in the IDLE CUTOFF position, open the throttle control 1/2 to full, and engage the starter motor (START). When the engine starts, advance the mixture control to the FULL RICH position and retard the throttle control promptly.

(Continued Next Page)

### **STARTING ENGINE (With Battery) (Continued)**

17. Oil Pressure - CHECK (verify that oil pressure increases into the GREEN BAND range in 30 to 60 seconds)
18. AMPS (M BATT and BATT S) - CHECK (verify charge shown (positive))
19. LOW VOLTS Annunciator - CHECK (verify annunciator is not shown)
20. NAV Light Switch - ON as required
21. AVIONICS Switch (BUS 1 and BUS 2) - ON

### **STARTING ENGINE (With External Power)**

1. Throttle Control - OPEN 1/4 INCH
2. Mixture Control - IDLE CUTOFF (pull full out)
3. STBY BATT Switch:
  - a. TEST - (hold for 10 seconds, verify green TEST lamp does not go off)
  - b. ARM - (verify that PFD comes on)
4. Engine Indication System - CHECK PARAMETERS (verify no red X's through ENGINE page indicators)
5. BUS E Volts - CHECK (verify 24 VOLTS minimum shown)
6. M BUS Volts - CHECK (verify 1.5 VOLTS or less shown)
7. BATT S Amps - CHECK (verify discharge shown (negative))
8. STBY BATT Annunciator - CHECK (verify annunciator is shown)
9. AVIONICS Switch (BUS 1 and BUS 2) - OFF
10. MASTER Switch (ALT and BAT) - OFF
11. Propeller Area - CLEAR (verify that all people and equipment are at a safe distance from the propeller)
12. External Power - CONNECT (to ground power receptacle)
13. MASTER Switch (ALT and BAT) - ON
14. BEACON Light Switch - ON
15. M BUS VOLTS - CHECK (verify that approximately 28 VOLTS is shown)

#### **NOTE**

If engine is warm, omit priming procedure steps 16 thru 18.

16. FUEL PUMP Switch - ON

(Continued Next Page)

## **STARTING ENGINE (With External Power)** (Continued)

17. Mixture Control - SET to FULL RICH (full forward) until stable fuel flow is indicated (approximately 3 to 5 seconds), then set to IDLE CUTOFF (full aft) position.
18. FUEL PUMP Switch - OFF
19. MAGNETOS Switch - START (release when engine starts)
20. Mixture Control - ADVANCE SMOOTHLY TO RICH (when engine starts)

### **NOTE**

If the engine is primed too much (flooded), place the mixture control in the IDLE CUTOFF position, open the throttle control 1/2 to full, and engage the starter motor (START). When the engine starts, advance the mixture control to the FULL RICH position and retard the throttle control promptly.

21. Oil Pressure - CHECK (verify oil pressure increases into the GREEN BAND range in 30 to 60 seconds)
22. Power - REDUCE TO IDLE
23. External Power - DISCONNECT FROM GROUND POWER (latch external power receptacle door)
24. Power - INCREASE (to approximately 1500 RPM for several minutes to charge battery)
25. AMPS (M BATT and BATT S) - CHECK (verify charge shown (positive))
26. LOW VOLTS Annunciator - CHECK (verify annunciator is not shown)
27. Internal Power - CHECK
  - a. MASTER Switch (ALT) - OFF
  - b. Taxi and Landing Lights

**For Airplanes Equipped With HID Landing/Taxi Lights**  
(1) TAXI and LAND Light Switches - ON

**For Airplanes Equipped With LED Landing/Taxi Lights**  
(1) LAND Switch - ON

  - c. Throttle Control - REDUCE TO IDLE
  - d. MASTER Switch (ALT and BAT) - ON
  - e. Throttle Control - INCREASE (to approximately 1500 RPM)

(Continued Next Page)

## **STARTING ENGINE (With External Power)** (Continued)

- f. M BATT Ammeter - CHECK (verify battery charging, amps positive)
- g. LOW VOLTS Annunciator - CHECK (verify annunciator is not shown)

### **WARNING**

**IF M BATT AMMETER DOES NOT SHOW POSITIVE CHARGE (+ AMPS), OR LOW VOLTS ANNUNCIATOR DOES NOT GO OFF, REMOVE THE BATTERY FROM THE AIRPLANE AND SERVICE OR REPLACE THE BATTERY BEFORE FLIGHT.**

- 28. NAV Light Switch - ON (as required)
- 29. AVIONICS Switch (BUS 1 and BUS 2) - ON

## **BEFORE TAKEOFF**

- 1. Parking Brake - SET
- 2. Pilot and Passenger Seat Backs - MOST UPRIGHT POSITION
- 3. Seats and Seat Belts - CHECK SECURE
- 4. Cabin Doors - CLOSED and LOCKED
- 5. Flight Controls - FREE and CORRECT
- 6. Flight Instruments (PFD) - CHECK (no red X's)
- 7. Altimeters:
  - a. PFD (BARO) - SET
  - b. Standby Altimeter - SET
- 8. ALT SEL - SET
- 9. Standby Flight Instruments - CHECK (if Standby Flight Instrument installed, CHECK no red X's (except for heading) and unit's backup battery status)
- 10. Fuel Quantity - CHECK (verify level is correct)

### **NOTE**

Flight is not recommended when both fuel quantity indicators are in the yellow band range.

- 11. Mixture Control - RICH
- 12. FUEL SELECTOR Valve - SET BOTH

(Continued Next Page)

**BEFORE TAKEOFF** (Continued)

13. Autopilot - ENGAGE (if installed)  
(push AP button on either PFD or MFD bezel)
14. Flight Controls - CHECK (verify autopilot can be overpowered in both pitch and roll axes)
15. A/P TRIM DISC Button - PRESS (if installed)  
(verify autopilot disengages and aural alert is heard)
16. Flight Director - OFF (if installed)  
(push FD button on either PFD or MFD bezel)
17. Elevator Trim Control - SET FOR TAKEOFF
18. Throttle Control - 1800 RPM
  - a. MAGNETOS Switch - CHECK (RPM drop should not exceed 175 RPM on either magneto or 50 RPM differential between magnetos)
  - b. VAC Indicator - CHECK (if installed)
  - c. Engine Indicators - CHECK
  - d. Ammeters and Voltmeters - CHECK
19. Annunciators - CHECK (verify no annunciators are shown)
20. Throttle Control - CHECK IDLE
21. Throttle Control - 1000 RPM or LESS
22. Throttle Control Friction Lock - ADJUST
23. COM Frequency(s) - SET
24. NAV Frequency(s) - SET
25. FMS/GPS Flight Plan - AS DESIRED

**NOTE**

GPS availability and status can be checked on AUX-GPS STATUS page.

26. XPDR - SET

(Continued Next Page)

## **BEFORE TAKEOFF** (Continued)

### 27. CDI Softkey - SELECT NAV SOURCE

#### **WARNING**

- **THE G1000 HSI SHOWS A COURSE DEVIATION INDICATOR FOR THE SELECTED GPS, NAV 1 OR NAV 2 NAVIGATION SOURCE. THE G1000 HSI DOES NOT PROVIDE A WARNING FLAG WHEN A VALID NAVIGATION SIGNAL IS NOT BEING SUPPLIED TO THE INDICATOR. WHEN A VALID NAVIGATION SIGNAL IS NOT BEING SUPPLIED, THE COURSE DEVIATION BAR (D-BAR) PART OF THE INDICATOR IS NOT SHOWN ON THE HSI COMPASS CARD. THE MISSING D-BAR IS CONSIDERED TO BE THE WARNING FLAG.**
- **WHEN THE AUTOPILOT IS ENGAGED IN NAV, APR OR BC OPERATING MODES, IF THE HSI NAVIGATION SOURCE IS CHANGED MANUALLY, USING THE CDI SOFTKEY OR SBAS IS UNAVAILABLE DURING A LP APPROACH (PRIOR TO FAF), THE NAVIGATION SIGNAL TO THE AUTOPILOT WILL BE INTERRUPTED AND CAUSE THE AUTOPILOT TO REVERT TO ROL MODE OPERATION. NO AURAL ALERT WILL BE PROVIDED. IN ROL MODE, THE AUTOPILOT WILL ONLY KEEP THE WINGS LEVEL AND WILL NOT CORRECT THE AIRPLANE HEADING OR COURSE. SET THE HDG BUG TO THE CORRECT HEADING AND VERIFY/SELECT THE CORRECT NAVIGATION SOURCE ON THE HSI BEFORE ENGAGING THE AUTOPILOT IN ANY OTHER OPERATING MODE.**

- 28. CABIN PWR 12V Switch - OFF (if installed)
- 29. Wing Flaps - UP - 10° (10° preferred)
- 30. Cabin Windows - CLOSED and LOCKED
- 31. STROBE Light Switch - ON
- 32. Brakes - RELEASE

## **TAKEOFF**

### **NORMAL TAKEOFF**

1. Wing Flaps - UP - 10° (10° preferred)
2. Throttle Control - FULL (push full in)
3. Mixture Control - RICH (above 3000 feet pressure altitude, lean for maximum RPM)
4. Elevator Control - LIFT NOSEWHEEL AT 55 KIAS
5. Climb Airspeed - 70 - 80 KIAS
6. Wing Flaps - RETRACT (at safe altitude)

### **SHORT FIELD TAKEOFF**

1. Wing Flaps - 10°
2. Brakes - APPLY
3. Throttle Control - FULL (push full in)
4. Mixture Control - RICH (above 3000 feet pressure altitude, lean for maximum RPM)
5. Brakes - RELEASE
6. Elevator Control - SLIGHTLY TAIL LOW
7. Climb Airspeed - 56 KIAS (until all obstacles are cleared)
8. Wing Flaps - RETRACT SLOWLY (when airspeed is more than 60 KIAS)

## **ENROUTE CLIMB**

1. Airspeed - 70 - 85 KIAS
2. Throttle Control - FULL (push full in)
3. Mixture Control - RICH (above 3000 feet pressure altitude, lean for maximum RPM)

### **NOTE**

For maximum performance climb speeds, refer to Section 5, Figure 5-6, Maximum Rate of Climb at 2550 Pounds.

## **CRUISE**

1. Power - 2100 - 2700 RPM (no more than 75% power recommended)
2. Elevator Trim Control - ADJUST
3. Mixture Control - LEAN (for desired performance or economy)
4. FMS/GPS - REVIEW and BRIEF (OBS/SUSP softkey operation for holding pattern procedure (IFR))

## DESCENT

1. Power - AS DESIRED
2. Mixture - ADJUST (if necessary to make engine run smoothly)
3. Altimeters:
  - a. PFD (BARO) - SET
  - b. Standby Altimeter - SET
4. ALT SEL - SET
5. CDI Softkey - SELECT NAV SOURCE
6. FMS/GPS - REVIEW and BRIEF (OBS/SUSP softkey operation for holding pattern procedure (IFR))

### WARNING

- **THE G1000 HSI SHOWS A COURSE DEVIATION INDICATOR FOR THE SELECTED GPS, NAV 1 OR NAV 2 NAVIGATION SOURCE. THE G1000 HSI DOES NOT PROVIDE A WARNING FLAG WHEN A VALID NAVIGATION SIGNAL IS NOT BEING SUPPLIED TO THE INDICATOR. WHEN A VALID NAVIGATION SIGNAL IS NOT BEING SUPPLIED, THE COURSE DEVIATION BAR (D-BAR) PART OF THE INDICATOR IS NOT SHOWN ON THE HSI COMPASS CARD. THE MISSING D-BAR IS CONSIDERED TO BE THE WARNING FLAG.**
  - **WHEN THE AUTOPILOT IS ENGAGED IN NAV, APR OR BC OPERATING MODES, IF THE HSI NAVIGATION SOURCE IS CHANGED MANUALLY, USING THE CDI SOFTKEY OR SBAS IS UNAVAILABLE DURING A LP APPROACH (PRIOR TO FAF), THE NAVIGATION SIGNAL TO THE AUTOPILOT WILL BE INTERRUPTED AND CAUSE THE AUTOPILOT TO REVERT TO ROL MODE OPERATION. NO AURAL ALERT WILL BE PROVIDED. IN ROL MODE, THE AUTOPILOT WILL ONLY KEEP THE WINGS LEVEL AND WILL NOT CORRECT THE AIRPLANE HEADING OR COURSE. SET THE HDG BUG TO THE CORRECT HEADING AND VERIFY/SELECT THE CORRECT NAVIGATION SOURCE ON THE HSI BEFORE ENGAGING THE AUTOPILOT IN ANY OTHER OPERATING MODE.**
7. FUEL SELECTOR Valve - BOTH
  8. Wing Flaps - AS DESIRED (UP - 10° below 110 KIAS)  
(10° - FULL below 85 KIAS)

## **BEFORE LANDING**

1. Pilot and Passenger Seat Backs - MOST UPRIGHT POSITION
2. Seats and Seat Belts - SECURED and LOCKED
3. FUEL SELECTOR Valve - BOTH
4. Mixture Control - RICH
5. LAND and TAXI Light Switches - ON
6. Autopilot - OFF (if installed)
7. CABIN PWR 12V Switch - OFF (if installed)

## **LANDING**

### **NORMAL LANDING**

1. Airspeed - 65 - 75 KIAS (Flaps UP)
2. Wing Flaps - AS DESIRED (UP - 10° below 110 KIAS)  
(10° - FULL below 85 KIAS)
3. Airspeed - 60 - 70 KIAS (Flaps FULL)
4. Elevator Trim Control - ADJUST
5. Touchdown - MAIN WHEELS FIRST
6. Landing Roll - LOWER NOSEWHEEL GENTLY
7. Braking - MINIMUM REQUIRED

### **SHORT FIELD LANDING**

1. Airspeed - 65 - 75 KIAS (Flaps UP)
2. Wing Flaps - FULL
3. Airspeed - 61 KIAS (until flare)
4. Elevator Trim Control - ADJUST
5. Power - REDUCE TO IDLE (as obstacle is cleared)
6. Touchdown - MAIN WHEELS FIRST
7. Brakes - APPLY HEAVILY
8. Wing Flaps - UP

(Continued Next Page)

## **LANDING** (Continued)

### **BALKED LANDING**

1. Throttle Control - FULL (push full in)
2. Wing Flaps - RETRACT to 20°
3. Climb Speed - 60 KIAS
4. Wing Flaps - 10° (as obstacle is cleared), then UP (after reaching a safe altitude and 65 KIAS)

### **AFTER LANDING**

1. Wing Flaps - UP
2. STROBE Light Switch - OFF
3. LAND Light Switch - OFF
4. TAXI Light Switch - AS DESIRED

### **SECURING AIRPLANE**

1. Parking Brake - SET
2. TAXI Light Switch - OFF
3. Throttle Control - IDLE (pull full out)
4. Electrical Equipment - OFF
5. AVIONICS Switch (BUS 1 and BUS 2) - OFF
6. Mixture Control - IDLE CUTOFF (pull full out)
7. MAGNETOS Switch - OFF
8. MASTER Switch (ALT and BAT) - OFF
9. STBY BATT Switch - OFF
10. Control Lock - INSTALL
11. FUEL SELECTOR Valve - LEFT or RIGHT (to prevent crossfeeding between tanks)

## **AMPLIFIED NORMAL PROCEDURES**

### **PREFLIGHT INSPECTION**

The preflight inspection, described in Figure 4-1 and adjacent checklist, is required prior to each flight. If the airplane has been in extended storage, has had recent major maintenance, or has been operated from rough runways, a more extensive exterior inspection is recommended.

Before every flight, check the condition of main and nose landing gear tires. Keep tires inflated to the pressure specified in Section 8, Airplane Handling, Service And Maintenance. Examine tire sidewalls for patterns of shallow cracks called weather checks. These cracks are evidence of tire deterioration caused by age, improper storage, or prolonged exposure to weather. Check the tread of the tire for depth, wear, and cuts. Replace the tire if fibers are visible.

After major maintenance has been performed, the flight and trim tab controls should be double checked for free and correct movement and security. The security of all inspection plates on the airplane should be checked following periodic inspections. If the airplane has been waxed or polished, check the external static pressure source hole for stoppage.

If the airplane has been kept in a crowded hangar, it should be checked for dents and scratches on wings, fuselage, and tail surfaces, damage to navigation, strobe lights, and avionics antennas. Check for damage to the nosewheel steering system, the result of exceeding nosewheel turning limits while towing.

(Continued Next Page)

## **PREFLIGHT INSPECTION** (Continued)

Outside storage for long periods may result in dust and dirt accumulation on the induction air filter, obstructions in airspeed system lines, water contaminants in fuel tanks, and insect/bird/rodent nests in any opening. If any water is detected in the fuel system, the fuel tank sump quick drain valves, fuel reservoir quick drain valve, and fuel strainer quick drain valve should all be thoroughly drained again. The wings should then be gently rocked and the tail lowered to the ground to move any further contaminants to the sampling points. Repeated samples should then be taken at all quick drain points until all contamination has been removed. If, after repeated sampling, evidence of contamination still exists, the fuel tanks should be completely drained and the fuel system cleaned.

If the airplane has been stored outside in windy or gusty areas, or tied down adjacent to taxiing airplanes, special attention should be paid to control surface stops, hinges, and brackets to detect the presence of potential wind damage.

If the airplane has been operated from muddy fields or in snow or slush, check the main and nose gear wheel fairings for obstructions and cleanliness. Operation from a gravel or cinder field will require extra attention to propeller tips and abrasion on leading edges of the horizontal tail. Stone damage to the propeller can seriously reduce the fatigue life of the blades.

Airplanes that are operated from rough fields, especially at high altitudes, are subjected to abnormal landing gear abuse. Frequently check all components of the landing gear, shock strut, tires, and brakes. If the shock strut is insufficiently extended, undue landing and taxi loads will be subjected to the airplane structure.

To prevent loss of fuel in flight, make sure the fuel tank filler caps are tightly sealed after any fuel system check or servicing. Fuel system vents should also be inspected for obstructions, ice or water, especially after exposure to cold, wet weather.

## STARTING ENGINE

In cooler weather, the engine compartment temperature drops off rapidly following engine shutdown and the injector nozzle lines remain nearly full of fuel.

In warmer weather, engine compartment temperatures may increase rapidly following engine shutdown, and fuel in the lines will vaporize and escape into the intake manifold. Hot weather starting procedures depend considerably on how soon the next engine start is attempted. Within the first 20 to 30 minutes after shutdown, the fuel manifold is adequately primed and the empty injector nozzle lines will fill before the engine dies. However, after approximately 30 minutes, the vaporized fuel in the manifold will have nearly dissipated and some slight priming could be required to refill the nozzle lines and keep the engine running after the initial start. Starting a hot engine is facilitated by advancing the mixture control promptly to 1/3 open when the engine starts, and then smoothly to full rich as power develops.

If the engine does not continue to run, set the FUEL PUMP switch to the ON position temporarily and adjust the throttle and/or mixture as necessary to keep the engine running. In the event of over priming or flooding, set the FUEL PUMP switch to OFF, open the throttle from 1/2 to full open, and continue cranking with the mixture in the IDLE CUTOFF position (pull full out). When the engine fires, smoothly advance the mixture control to full rich and retard the throttle to desired idle speed.

If the engine is under primed (most likely in cold weather with a cold engine), it will not start at all, and additional priming will be necessary.

After starting, if the oil pressure gage does not begin to show pressure within 30 seconds in warmer temperatures and approximately one minute in very cold weather, stop the engine and find the cause before continued operation. Lack of oil pressure can cause serious engine damage.

### NOTE

Additional details concerning cold weather starting and operation may be found under COLD WEATHER OPERATION paragraphs in this section.

(Continued Next Page)

## **STARTING ENGINE** (Continued)

### **RECOMMENDED STARTER DUTY CYCLE**

Operate the starter motor for 10 seconds followed by a 20 second cool down period. This cycle can be repeated two additional times, followed by a ten minute cool down period before resuming cranking. After cool down, operate the starter motor again, three cycles of 10 seconds followed by 20 seconds of cool down. If the engine still does not start, try to find the cause.

### **LEANING FOR GROUND OPERATIONS**

For all ground operations, after starting the engine and when the engine is running smoothly:

1. Set the throttle control to 1200 RPM.
2. Lean the mixture for maximum RPM.
3. Set the throttle control to an RPM appropriate for ground operations (800 to 1000 RPM recommended).

#### **NOTE**

If ground operation will be required after the BEFORE TAKEOFF checklist is completed, lean the mixture again (as described above) until ready for the TAKEOFF checklist.

## FUEL VAPOR PROCEDURES

The engine fuel system can cause fuel vapor formation on the ground during warm weather. This will generally occur when the outside ambient air temperature is above 80°F. Vapor formation may increase when the engine fuel flows are lower at idle and taxi engine speeds. The following procedures are recommended when engine idle speed and fuel flow fluctuations show that fuel vapor may be present:

1. With the mixture full rich, set the throttle at 1800 RPM to 2000 RPM. Maintain this power setting for 1 to 2 minutes or until smooth engine operation returns.
2. Retard the throttle to the idle stop to verify normal engine operation.
3. Advance the throttle to 1200 RPM and lean the mixture as described under FUEL SAVINGS PROCEDURES FOR FLIGHT TRAINING OPERATIONS.
4. In addition to the above procedures, the auxiliary fuel pump may be turned ON with the mixture adjusted as required to aid vapor suppression during ground operations. The auxiliary fuel pump should be turned OFF prior to takeoff.
5. Just prior to TAKEOFF, apply full throttle for approximately 10 seconds to verify smooth engine operation for takeoff.

### NOTE

When the engine is operated above 1800 RPM, the resulting increased fuel flow results in lower fuel temperatures throughout the engine fuel system. This increased flow purges the fuel vapor and the cooler fuel minimizes vapor formation.

In addition to the previous procedures, the sections below should be reviewed, and where applicable, adhered to:

Section 3 -Take note of the excessive fuel vapor procedures in both the checklist and the amplified procedures sections.

Section 4 -Take note of the hot weather operational notes and procedures in both the checklist and the amplified procedures sections.

## TAXIING

When taxiing, it is important that speed and use of brakes be held to a minimum and that all controls be utilized, refer to Figure 4-2, Taxiing Diagram, to maintain directional control and balance.

Taxiing over loose gravel or cinders should be done at low engine speed to avoid abrasion and stone damage to the propeller tips.

### NOTE

The LOW VOLTS annunciator may come on when the engine is operated at low RPM with a high load on the electrical system. If this is the case, the LOW VOLTS annunciator will go off when the engine is run at higher RPM to provide greater alternator system output. Verify that the M BATT AMPS indication shows positive (charging) current at the higher RPM.

(Continued Next Page)

**TAXIING** (Continued)

**TAXIING DIAGRAM**

B3092

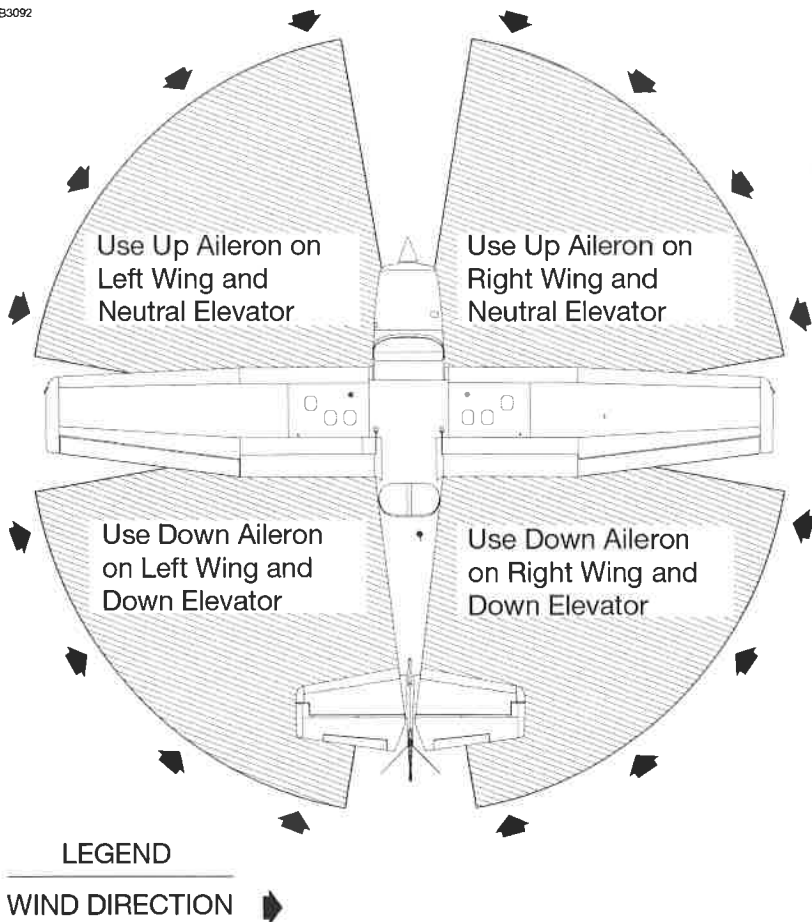

0585T1020

**NOTE**

Strong quartering tail winds require caution. Avoid sudden bursts of the throttle and sharp braking when the airplane is in this attitude. Use the steerable nosewheel and rudder to maintain direction.

Figure 4-2\*

## **BEFORE TAKEOFF**

### **WARM UP**

If the engine idles smoothly with the throttle against the idle stop, (approximately 675 RPM) and accelerates smoothly, the engine is ready for takeoff. Since the engine is closely cowled for efficient in-flight engine cooling, the airplane should be pointed into the wind to avoid overheating during prolonged engine operation on the ground. Long periods of idling may cause fouled spark plugs.

### **MAGNETO CHECK**

The magneto check must be made at 1800 RPM. Turn the MAGNETOS switch from the BOTH position to the R position. Note the new RPM, then turn the MAGNETOS switch back to the BOTH position to clear the spark plugs. Turn the MAGNETOS switch to the L position, note the new RPM, then turn the switch back to the BOTH position. RPM decrease should not be more than 175 RPM on either magneto or be greater than 50 RPM differential between magnetos. If there is a doubt concerning operation of the ignition system, RPM checks at higher engine speeds will usually confirm whether a deficiency exists.

No RPM drop may indicate a faulty ground to one magneto or magneto timing set in advance of the angle specified.

### **ALTERNATOR CHECK**

Make sure that both the alternator and alternator control unit are operating properly before night or instrument flight, or flights where electrical power is essential. Check the electrical system during the MAGNETO check (1800 RPM) by setting all electrical equipment required for the flight to the ON position. When the alternator and alternator control unit are both operating properly, the ammeters will show zero or positive current (amps), the voltmeters should show between 27 to 29 volts, and no electrical system annunciations will appear. Reduce the electrical load before reducing engine speed so the battery will not discharge while the engine is at idle.

(Continued Next Page)

## **BEFORE TAKEOFF** (Continued)

### **ELEVATOR TRIM**

The elevator trim tab is in the takeoff position when the trim pointer is aligned with the index mark on the pedestal cover. Adjust the trim wheel during flight as necessary to make control wheel forces more neutral.

### **LANDING/TAXI LIGHTS**

It is recommended that the taxi light, or recognition light (if installed), be used to enhance the visibility of the airplane in the traffic pattern or enroute. This will extend the service life of the landing light.

## **TAKEOFF**

### **POWER CHECK**

It is important to check full throttle engine operation early in the takeoff roll. Any sign of rough engine operation or sluggish engine acceleration is good cause for discontinuing the takeoff. If this occurs, you are justified in making a thorough full throttle static run-up before another takeoff is attempted. The engine should run smoothly and turn approximately 2300 - 2400 RPM with the mixture leaned to provide maximum RPM.

Full throttle run-ups over loose gravel are especially harmful to propeller tips. When takeoffs must be made over a gravel surface, advance the throttle slowly. This allows the airplane to start rolling before high RPM is developed, and the gravel will be blown behind the propeller rather than pulled into it.

Prior to takeoff from fields above 3000 feet pressure altitude, the mixture should be leaned to give maximum RPM at full throttle, with the airplane not moving.

After full throttle is applied, adjust the throttle friction lock clockwise to prevent the throttle from moving back from a maximum power position. Similar friction lock adjustments should be made as required in other flight conditions to hold the throttle setting.

(Continued Next Page)

## TAKEOFF (Continued)

### WING FLAP SETTINGS

Normal takeoffs use wing flaps UP - 10°. Using 10° wing flaps reduces the ground roll and total distance over an obstacle by approximately 10 percent. **Flap deflections greater than 10° are not approved for takeoff.** If 10° wing flaps are used for takeoff, the flaps should stay at 10° until all obstacles are cleared and a safe flap retraction speed of 60 KIAS is reached. For a short field, 10° wing flaps and an obstacle clearance speed of 56 KIAS should be used.

Soft or rough field takeoffs are performed with 10° flaps by lifting the airplane off the ground as soon as practical in a slightly tail low attitude. If no obstacles are ahead, the airplane should be leveled off immediately to accelerate to a higher climb speed. When departing a soft field with an aft C.G. loading, the elevator trim control should be adjusted towards the nose down direction to give comfortable control wheel forces during the initial climb.

### CROSSWIND TAKEOFF

Takeoffs under strong crosswind conditions normally are performed with the minimum flap setting necessary for the field length, to minimize the drift angle immediately after takeoff. With the ailerons partially deflected into the wind, the airplane is accelerated to a speed slightly higher than normal, then the elevator control is used to quickly, but carefully, lift the airplane off the ground and to prevent possible settling back to the runway while drifting. When clear of the ground, make a coordinated turn into the wind to correct for drift.

Takeoffs with flaps UP - 10° have been demonstrated with direct crosswinds of 20 knots. If field length permits, flaps UP is preferred for operations with strong crosswinds above 15 Knots.

## **ENROUTE CLIMB**

Normal enroute climbs are performed with flaps up, at full throttle and 75 to 85 KIAS for the best combination of performance, visibility and engine cooling. The mixture should be full rich during climb at altitudes up to 3000 feet pressure altitude. Above 3000 feet pressure altitude, the mixture can be leaned as needed for increased power or to provide smoother engine operation.

If it is necessary to climb more rapidly to clear mountains or reach favorable winds at higher altitudes, the best rate of climb speed should be used with Maximum Continuous Power (MCP). This speed is 74 KIAS at sea level, decreasing to 72 KIAS at 10,000 feet.

If an obstruction dictates the use of a steep climb angle, the best angle of climb speed should be used with flaps UP and MCP. This speed is 62 KIAS at sea level, increasing to 67 KIAS at 10,000 feet. This type of climb should be of the minimum duration and engine temperatures should be carefully monitored due to the low climb speed.

## CRUISE

Normal cruise is performed between 45% and 75% power. The engine RPM and corresponding fuel consumption for various altitudes can be determined by using the data in Section 5.

### NOTE

Cruise flight should use 75% power as much as possible until the engine has operated for a total of 50 hours or oil consumption has stabilized. Operation at this higher power will ensure proper seating of the piston rings and is applicable to new engines, and engines in service following cylinder replacement or top overhaul of one or more cylinders.

The Cruise Performance charts in Section 5 provide the pilot with flight planning information for the Model 172S in still air with speed fairings installed. Power, altitude, and winds determine the time and fuel needed to complete any flight.

The Cruise Performance Table, Figure 4-3, shows the true airspeed and nautical miles per gallon during cruise for various altitudes and percent powers, and is based on standard conditions and zero wind. This table should be used as a guide, along with the available winds aloft information, to determine the most favorable altitude and power setting for a given trip. The selection of cruise altitude on the basis of the most favorable wind conditions and the use of low power settings are significant factors that should be considered on every trip to reduce fuel consumption.

In addition to power settings, proper leaning techniques also contribute to greater range and are figured into cruise performance tables. To achieve the recommended lean mixture fuel consumption figures shown in Section 5, the mixture should be leaned using the Exhaust Gas Temperature (EGT) indicator as noted.

(Continued Next Page)

**CRUISE** (Continued)

**CRUISE PERFORMANCE TABLE**

CONDITIONS:  
 Standard Conditions          Zero Wind

ALTITUDE FEET	75% POWER		65% POWER		55% POWER	
	KTAS	NMPG	KTAS	NMPG	KTAS	NMPG
Sea Level	114	11.2	108	12.0	101	12.8
4000	119	11.7	112	12.4	104	13.2
8000	124	12.2	117	12.9	107	13.6

Figure 4-3

The Cruise Performance charts in Section 5 provide the pilot with cruise performance at maximum gross weight. When normal cruise is performed at reduced weights there is an increase in true airspeed. During normal cruise at power settings between 55% and 75%, the true airspeed will increase approximately 1 knot for every 150 pounds below maximum gross weight. During normal cruise at power settings below 65%, the true airspeed will increase approximately 1 knot for every 125 pounds below maximum gross weight.

The fuel injection system employed on this engine is considered to be non-icing. In the event that unusual conditions cause the intake air filter to become clogged or iced over, an alternate intake air door opens automatically for the most efficient use of either normal or alternate air, depending on the amount of filter blockage. Due to the lower intake pressure available through the alternate air door or a partially blocked filter, engine RPM can decrease from a cruise power setting. This RPM loss should be recovered by increasing the throttle setting to maintain desired power.

(Continued Next Page)

## **CRUISE** (Continued)

### **LEANING USING EXHAUST GAS TEMPERATURE (EGT)**

The cruise performance data in this POH is based on the recommended lean mixture setting determined from the maximum or peak EGT at power settings of 75% MCP and lower. The 172S Nav III provides EGT indications for all (4) engine cylinders. The ability to monitor all cylinders is an aid in early identification and correction of fuel injection problems.

#### **NOTE**

All engine cylinders do not receive identical fuel/air mixtures (due to unequal intake pipe lengths, uneven intake air temperatures, fuel injection nozzle tolerances etc.). However, all cylinder EGTs should be within approximately 100°F of each other during normal operations. An EGT difference greater than 100°F between cylinders indicates that fuel injection system maintenance is necessary.

EGT is displayed on the EIS ENGINE and LEAN pages. The ENGINE page has a horizontal scale with a temperature indicator (inverted triangle) with a number representing the cylinder with the highest EGT.

The EIS LEAN page provides vertical bar graph displays showing EGT for all cylinders. The cylinder with the highest EGT is shown in cyan (light blue). The numerical value for the highest EGT is located below the bar. The EGT and Cylinder Head Temperature (CHT) value for any cylinder may be shown by using the CYL SLCT softkey to select the desired cylinder. After a short period without CYL SLCT softkey activity, automatic indication of the highest EGT and CHT will start again.

(Continued Next Page)

## **CRUISE** (Continued)

### **LEANING USING EXHAUST GAS TEMPERATURE (EGT)** (Continued)

To aid in leaning the mixture, push the ENGINE, LEAN and ASSIST softkeys,  $\Delta$ PEAK °F will display below the EGT °F numerical value. Lean the mixture by slowly turning the mixture control knob in the counterclockwise direction while monitoring EGTs. As EGTs increase, continue to lean the mixture until the hottest (cyan) cylinder reaches peak EGT. This is identified by the EGT bar graph for that cylinder changing to cyan with a hollow bar at the top. Note the  $\Delta$ PEAK °F and FLOW GPH values for the first peaked cylinder. Peak EGT is represented by  $\Delta$ PEAK 0°F, if  $\Delta$ PEAK °F value is negative (-) the mixture can be on the lean side of peak. Enrichen the mixture by slowly turning the mixture control clockwise and monitor both fuel flow and EGTs until the leanest cylinder returns to peak EGT ( $\Delta$ PEAK 0°F) or desired setting based on the Exhaust Gas Temperature (EGT) Table, Figure 4-4.

$\Delta$ PEAK °F values rich of peak will also be a negative (-) value (-50°F). The lean assist system calculation is defined such that the peak EGT is the highest value and any lesser value is represented with a negative (-) value, whether on the lean or rich side of the peak.

#### **NOTE**

The 172S engine manufacturer, Textron Lycoming, has not approved operation of the engine at fuel flow rates (mixture settings) less than necessary to reach peak EGT in the leanest cylinder (the first cylinder to reach peak EGT). Use FULL RICH mixture when operating the engine above 75% power.

(Continued Next Page)

**CRUISE** (Continued)

**LEANING USING EXHAUST GAS TEMPERATURE (EGT)**  
(Continued)

**EXHAUST GAS TEMPERATURE (EGT)**

<b>MIXTURE DESCRIPTION</b>	<b>EXHAUST GAS TEMPERATURE (EGT)</b>
RECOMMENDED LEAN (Pilot's Operating Handbook)	50°F Rich of Peak EGT
BEST ECONOMY	Peak EGT

Figure 4-4

Operation at peak EGT provides the best fuel economy. This results in approximately 4% greater range than shown in this POH accompanied by approximately a 3 knot decrease in speed.

Under some conditions, engine roughness may occur while operating at peak EGT. In this case, operate at the recommended lean mixture.

**NOTE**

- Any change in altitude or power setting will require a change in the recommended lean mixture setting and a recheck of the EGT setting.
- The EGT indicators take several seconds, after a mixture adjustment, to start to show EGT changes. Finding peak EGT and adjusting the mixture to the applicable setting should take approximately one minute when the adjustments are made carefully and accurately. Adjusting the mixture quickly is not recommended.

(Continued Next Page)

## **CRUISE** (Continued)

### **FUEL SAVINGS PROCEDURES FOR FLIGHT TRAINING OPERATIONS**

For best fuel economy during flight training operations, the following procedures are recommended.

1. After engine start and for all ground operations, set the throttle to 1200 RPM and lean the mixture for maximum RPM. After leaning, set the throttle to the appropriate RPM for ground operations. Leave the mixture at this setting until beginning the BEFORE TAKEOFF checklist. After the BEFORE TAKEOFF checklist is complete, lean the mixture again as described above until ready to perform the TAKEOFF checklist.
2. Lean the mixture for maximum RPM during full throttle climbs above 3000 feet. The mixture may remain leaned (maximum RPM at full throttle) for practicing maneuvers such as stalls and slow flight.
3. Lean the mixture for maximum RPM during all operations at any altitude, including those below 3000 feet, when using 75% or less power.

#### **NOTE**

- When cruising or maneuvering at 75% power or less, the mixture may be further leaned until the EGT indicator peaks and is then enriched 50°F. This is especially applicable to cross-country training flights, but should be practiced during transition flight to and from the practice area as well.
- Using the above recommended procedures can provide fuel savings in excess of 5% when compared to typical training operations at full rich mixture. In addition, the above procedures will minimize spark plug fouling since the reduction in fuel consumption results in a proportional reduction in tetraethyl lead passing through the engine.

(Continued Next Page)

## STALLS

The stall characteristics are conventional and aural warning is provided by a stall warning horn which sounds between 5 and 10 knots above the stall in all configurations.

Power off stall speeds at maximum weight for both forward and aft C.G. positions are presented in Section 5.

## SPINS

Intentional spins are approved when the airplane is operated in the utility category. Spins with baggage loadings or occupied rear seat(s) are not approved.

However, before attempting to perform spins several items should be carefully considered to assure a safe flight. No spins should be attempted without first having received dual instruction both in spin entries and spin recoveries from a qualified instructor who is familiar with the spin characteristics of the Cessna 172S NAV III airplane.

The cabin should be clean and all loose equipment (including the microphone and rear seat belts) should be stowed or secured. For a solo flight in which spins will be conducted, the front passenger's seat belt and shoulder harness should also be secured. Care should be taken to ensure that the pilot can easily reach the flight controls and produce maximum control travels.

(Continued Next Page)

## **SPINS** (Continued)

It is recommended that entries be accomplished at high enough altitude that recoveries are completed 4000 feet or more Above Ground Level (AGL). At least 1000 feet of altitude loss should be allowed for a 1-turn spin and recovery, while a 6-turn spin and recovery may require somewhat more than twice that amount. For example, the recommended entry altitude for a 6-turn spin would be 6000 feet AGL. In any case, entries should be planned so that recoveries are completed well above the minimum 1500 feet AGL required by 14 CFR 91.303. Another reason for using high altitudes for practicing spins is that a greater field of view is provided which will assist in maintaining pilot orientation.

The normal entry is made from a power off stall. As the stall is approached, the elevator control should be smoothly pulled to the full aft position. Just prior to reaching the stall "break", rudder control in the desired direction of the spin rotation should be applied so that full rudder deflection is reached almost simultaneously with reaching full aft elevator. A slightly greater rate of deceleration than for normal stall entries, application of ailerons in the direction of the desired spin, and the use of power at the entry will assure more consistent and positive entries to the spin. As the airplane begins to spin, reduce the power to idle and return the ailerons to neutral. Both elevator and rudder controls should be held full with the spin until the spin recovery is initiated. An inadvertent relaxation of either of these controls could result in the development of a nose down spiral.

For the purpose of training in spins and spin recoveries, a 1 or 2 turn spin is adequate and should be used. Up to 2 turns, the spin will progress to a fairly rapid rate of rotation and a steep attitude. Application of recovery controls will produce prompt recoveries (within 1/4 turn). During extended spins of two to three turns or more, the spin will tend to change into a spiral, particularly to the right. This will be accompanied by an increase in airspeed and gravity loads on the airplane. If this occurs, recovery should be accomplished promptly but smoothly by leveling the wings and recovering from the resulting dive.

(Continued Next Page)

## **SPINS** (Continued)

Regardless of how many turns the spin is held or how it is entered, the following recovery technique should be used:

1. VERIFY THAT THROTTLE IS IN IDLE POSITION AND AILERONS ARE NEUTRAL.
2. APPLY AND **HOLD** FULL RUDDER OPPOSITE TO THE DIRECTION OF ROTATION.
3. JUST **AFTER** THE RUDDER REACHES THE STOP, MOVE THE CONTROL WHEEL **BRISKLY** FORWARD FAR ENOUGH TO BREAK THE STALL.
4. **HOLD** THESE CONTROL INPUTS UNTIL ROTATION STOPS.
5. AS ROTATION STOPS, NEUTRALIZE RUDDER, AND MAKE A SMOOTH RECOVERY FROM THE RESULTING DIVE.

### **NOTE**

If disorientation makes the direction of rotation difficult to determine, see the turn vector near the index at the top of the Horizontal Situation Indicator (HSI).

Variations in basic airplane rigging or in weight and balance due to installed equipment or right seat occupancy can cause differences in behavior, particularly in extended spins. These differences are normal and will result in variations in the spin characteristics and in the spiraling tendencies for spins of more than 2 turns. However, the recovery technique should always be used and will result in the most expeditious recovery from any spin.

Intentional spins with flaps extended are prohibited, since the high airspeeds which may occur during recovery can be more than the flap airspeed limitation and can damage the flap and wing structures.

## **LANDING**

### **NORMAL LANDING**

Normal landing approaches can be made with power on or power off with any flap setting within the flap airspeed limits. Surface winds and air turbulence are usually the primary factors in determining the most comfortable approach speeds. Steep slips with flap settings greater than 20° can cause a slight tendency for the elevator to oscillate under certain combinations of airspeed, sideslip angle, and center of gravity loadings.

Landing at slower speeds will result in shorter landing distances and minimum wear to tires and brakes. Power must be at idle as the main wheels touch the ground. The main wheels must touch the ground before the nosewheel. The nosewheel must be lowered to the runway carefully after the speed has diminished to avoid unnecessary nose gear loads. This procedure is very important for rough or soft field landings.

### **SHORT FIELD LANDING**

For a short field landing in smooth air conditions, approach at 61 KIAS with FULL flaps using enough power to control the glide path. Slightly higher approach speeds should be used in turbulent air conditions. After all approach obstacles are cleared, smoothly reduce power and hold the approach speed by lowering the nose of the airplane. The main wheels must touch the ground before the nosewheel with power at idle. Immediately after the main wheels touch the ground, carefully lower the nosewheel and apply heavy braking as required. For maximum brake performance, retract the flaps, hold the control wheel full back, and apply maximum brake pressure without skidding the tires.

(Continued Next Page)

## **LANDING** (Continued)

### **CROSSWIND LANDING**

When landing in a strong crosswind, use the minimum flap setting required for the field length. If flap settings greater than 20° are used in sideslips with full rudder deflection, some elevator oscillation may be felt at normal approach speeds. However, this does not affect control of the airplane. Although the crab or combination method of drift correction may be used, the wing low method gives the best control. After touchdown, hold a straight course with the steerable nosewheel, with aileron deflection as applicable, and occasional braking if necessary.

The maximum allowable crosswind velocity is dependent upon pilot capability as well as airplane limitations. Landings in direct crosswinds of 15 knots have been demonstrated with flaps FULL. Landings in direct crosswinds of 20 knots have been demonstrated with flaps 10°. Less flaps may be used depending on the field length.

### **BALKED LANDING**

In a balked landing (go-around) climb, reduce the flap setting to 20° immediately after full power is applied and climb at 60 KIAS. If obstacles must be cleared during the go-around climb, reduce the wing flap setting to 10° and maintain a safe airspeed until the obstacles are cleared. Above 3000 feet pressure altitude, lean the mixture to obtain maximum RPM. After clearing any obstacles, carefully retract the flaps and allow the airplane to accelerate to normal climb airspeed.

## COLD WEATHER OPERATIONS

Special consideration should be given to the operation of the airplane fuel system during the winter season or prior to any flight in cold temperatures. Proper preflight draining of the fuel system is especially important and will eliminate any free water accumulation. The use of additives such as isopropyl alcohol or Diethylene Glycol Monomethyl Ether (DIEGME) may also be desirable. Refer to Section 8 for information on the proper use of additives.

Cold weather often causes conditions that require special care during airplane operations. **Even small accumulations of frost, ice, or snow must be removed, particularly from wing, tail and all control surfaces to assure satisfactory flight performance and handling.** Also, control surfaces must be free of any internal accumulations of ice or snow.

If snow or slush covers the takeoff surface, allowance must be made for takeoff distances which will be increasingly extended as the snow or slush depth increases. The depth and consistency of this cover can, in fact, prevent takeoff in many instances.

(Continued Next Page)

## **COLD WEATHER OPERATION** (Continued)

### **STARTING**

When air temperatures are below 20°F (-6°C), use an external preheater and an external power source whenever possible to obtain positive starting and to reduce wear and abuse to the engine and electrical system. Preheat will thaw the oil trapped in the oil cooler, which probably will be congealed prior to starting in extremely cold temperatures.

### **WARNING**

**WHEN TURNING THE PROPELLER BY HAND, TREAT IT AS IF THE MAGNETOS SWITCH IS IN THE ON POSITION. A LOOSE OR BROKEN GROUND WIRE ON EITHER MAGNETO COULD ENERGIZE THE ENGINE.**

Prior to starting on cold mornings, it is advisable to turn the propeller manually through several engine compression cycles by hand to loosen the oil, so the engine cranks (motors) more easily and uses less battery power. When the propeller is turned manually, turn it in the opposite direction to normal engine rotation for greater safety. Opposite rotation disengages the magneto impulse couplings and prevents possible unwanted ignition.

When using an external power source, the MASTER switch ALT and BAT sections must be in the OFF position before connecting the external power source to the airplane receptacle. Refer to Section 7, External Power Receptacle, for external power source operations.

(Continued Next Page)

## **COLD WEATHER OPERATION** (Continued)

### **STARTING** (Continued)

Cold weather starting procedures are the same as the normal starting procedures. However, to conserve battery power the beacon light can be left off until the engine is started. Use caution to prevent inadvertent forward movement of the airplane during starting when parked on snow or ice.

During cold weather starting, when performing the Standby Battery energy level test, the test lamp may not illuminate and the BUS E volts may be less than 24 volts before turning on the MASTER (ALT and BAT) switch. After engine start, verify the S BATT ammeter shows a charge (positive) at 1000 RPM or greater. Prior to takeoff verify the S BATT ammeter shows a charge less than 0.4 amps.

### **NOTE**

If the engine does not start during the first few attempts, or if engine firing diminishes in strength, the spark plugs may be frosted over. Preheat must be used before another start is attempted.

During cold weather operations, the oil temperature indicator may not be in the green band prior to takeoff if outside air temperatures are very cold. After a suitable warm up period (2 to 5 minutes at 1000 RPM), accelerate the engine several times to higher engine RPMs. If the engine accelerates smoothly and the oil pressure remains normal and steady, the airplane is ready for takeoff.

### **WINTERIZATION KIT**

An optional winterization kit is available and may be utilized when cold weather operations are conducted. Refer to Section 9, Supplement 4 for installation and operational details.

## HOT WEATHER OPERATIONS

Refer to the general warm temperature starting information under Starting Engine in this section. Avoid prolonged engine operation on the ground.

## NOISE CHARACTERISTICS

The certified takeoff noise level for the Model 172S at 2550 pounds maximum weight is 75.1 dB(A) per 14 CFR 36 Appendix G (through Amendment 36-21) and 78.2 dB(A) per ICAO Annex 16 Chapter 10 (through Amendment 4). No determination has been made that the noise levels of this airplane are, or should be, acceptable or unacceptable for operation at, into, or out of, any airport.

The following procedures are suggested to minimize the effect of airplane noise on the public:

1. Pilots operating airplanes under VFR over outdoor assemblies of persons, recreational and park areas, and other noise sensitive areas should make every effort to fly not less than 2000 feet AGL, weather permitting, even though flight at a lower level may be consistent with the provisions of government regulations.
2. During departure from or approach to an airport, climb after takeoff and descent for landing should be made so as to avoid prolonged flight at low altitude near noise sensitive areas.

### NOTE

The above recommended procedures do not apply where they would conflict with Air Traffic Control clearances or instructions, or where, in the pilot's judgment, an altitude of less than 2000 feet AGL is necessary to adequately exercise the duty to see and avoid other airplanes.

## PERFORMANCE

### TABLE OF CONTENTS

	Page
Introduction . . . . .	5-3
Use of Performance Charts . . . . .	5-3
Sample Problem . . . . .	5-4
Takeoff . . . . .	5-5
Cruise . . . . .	5-6
Fuel Required . . . . .	5-7
Landing . . . . .	5-9
Demonstrated Operating Temperature . . . . .	5-9
Airspeed Calibration - Normal Static Source . . . . .	5-10
Airspeed Calibration - Alternate Static Source . . . . .	5-11
Temperature Conversion Chart . . . . .	5-12
Stall Speeds At 2550 Pounds . . . . .	5-13
Crosswind Component . . . . .	5-14
Short Field Takeoff Distance At 2550 Pounds . . . . .	5-15
Short Field Takeoff Distance At 2400 Pounds . . . . .	5-16
Short Field Takeoff Distance At 2200 Pounds . . . . .	5-17
Maximum Rate Of Climb At 2550 Pounds . . . . .	5-18
Time, Fuel And Distance To Climb At 2550 Pounds . . . . .	5-19
Cruise Performance . . . . .	5-20
Range Profile . . . . .	5-22
Endurance Profile . . . . .	5-23
Short Field Landing Distance At 2550 Pounds . . . . .	5-24



## **INTRODUCTION**

Performance data charts on the following pages are presented so that you may know what to expect from the airplane under various conditions and to facilitate the planning of flights in detail with reasonable accuracy. The data in the charts has been computed from actual flight tests with the airplane and engine in good condition and using average piloting techniques.

It should be noted that performance information presented in the range and endurance profile charts allows for 45 minutes reserve fuel at the specified power setting. Fuel flow data for cruise is based on the recommended lean mixture setting at all altitudes. Some indeterminate variables such as mixture leaning technique, fuel metering characteristics, engine and propeller condition, and air turbulence may account for variations of 10% or more in range and endurance. Therefore, it is important to utilize all available information to estimate the fuel required for the particular flight and to flight plan in a conservative manner.

## **USE OF PERFORMANCE CHARTS**

Performance data is presented in tabular or graphical form to illustrate the effect of different variables. Sufficiently detailed information is provided in the tables so that conservative values can be selected and used to determine the particular performance figure with reasonable accuracy.

## SAMPLE PROBLEM

The following sample flight problem utilizes information from the various charts to determine the predicted performance data for a typical flight. Assume the following information has already been determined:

### AIRPLANE CONFIGURATION:

Takeoff weight	2550 Pounds
Usable fuel	53.0 Gallons

### TAKEOFF CONDITIONS:

Field pressure altitude	1500 Feet
Temperature	28°C (16°C Above Standard)
Wind component along runway	12 Knot Head Wind
Field length	3500 Feet

### CRUISE CONDITIONS:

Total distance	360 Nautical Miles
Pressure altitude	7500 Feet
Temperature	16°C (16°C Above Standard)
Expected wind enroute	10 Knot Head Wind

### LANDING CONDITIONS:

Field pressure altitude	2000 Feet
Temperature	25°C
Field length	3000 Feet

(Continued Next Page)

## SAMPLE PROBLEM (Continued)

### TAKEOFF

The takeoff distance chart, Figure 5-5, should be consulted, keeping in mind that distances shown are based on the short field technique. Conservative distances can be established by reading the chart at the next higher value of weight, altitude and temperature. For example, in this particular sample problem, the takeoff distance information presented for a weight of 2550 pounds, pressure altitude of 2000 feet and a temperature of 30°C should be used and results in the following:

Ground roll	1285 Feet
Total distance to clear a 50-foot obstacle	2190 Feet

These distances are well within the available takeoff field length. However, a correction for the effect of wind may be made based on information presented in the note section of the takeoff chart. The correction for a 12 knot head wind is:

$$\frac{12 \text{ Knots}}{9 \text{ Knots}} \times 10\% = 13\% \text{ Decrease}$$

This results in the following distances, corrected for wind:

Ground roll, zero wind	1285 Feet
Decrease in ground roll (1285 feet X 13%)	<u>-167 Feet</u>
Corrected ground roll	1118 Feet

Total distance to clear a 50-foot obstacle, zero wind	2190 Feet
Decrease in total distance (2190 feet X 13%)	<u>-285 Feet</u>
Corrected total distance to clear 50-foot obstacle	1905 Feet

(Continued Next Page)

## SAMPLE PROBLEM (Continued)

### CRUISE

The cruising altitude should be selected based on a consideration of trip length, winds aloft and the airplane's performance. A typical cruising altitude and the expected wind enroute have been given for this sample problem. However, the power setting selection for cruise must be determined based on several considerations. These include the cruise performance characteristics presented in Figure 5-8, the range profile chart presented in Figure 5-9, and the endurance profile chart presented in Figure 5-10.

The relationship between power and range is illustrated by the range profile chart. Considerable fuel savings and longer range result when lower power settings are used. For this sample problem, a cruise power of approximately 65% will be used.

The cruise performance chart, Figure 5-8, is entered at 8000 feet pressure altitude and 20°C above standard temperature. These values most nearly correspond to the planned altitude and expected temperature conditions. The engine speed chosen is 2600 RPM, which results in the following:

Power	64%
True airspeed	117 Knots
Cruise fuel flow	8.9 GPH

(Continued Next Page)

## SAMPLE PROBLEM (Continued)

### FUEL REQUIRED

The total fuel requirement for the flight may be estimated using the performance information in Figure 5-7 and Figure 5-8. For this sample problem, the time, fuel and distance to climb may be determined from Figure 5-7 for normal climb. The difference between the values shown in the table for 2000 feet and 8000 feet results in the following:

Time: 11 Minutes  
 Fuel: 2.2 Gallons  
 Distance: 15 Nautical Miles

These values are for a standard temperature and are sufficiently accurate for most flight planning purposes. However, a further correction for the effect of temperature may be made as noted on the climb chart. The approximate effect of a nonstandard temperature is to increase the time, fuel and distance by 10% for each 10°C above standard temperature, due to the lower rate of climb. In this case, assuming a temperature 16°C above standard the correction would be:

$$\frac{16^{\circ}\text{C}}{10^{\circ}\text{C}} \times 10\% = 16\% \text{ Increase}$$

With this factor included, the fuel estimate would be calculated as follows:

Fuel to climb, standard temperature	2.2 Gallons
Increase due to non-standard temperature (2.2 X 16%)	0.4 Gallons
Corrected fuel to climb	<u>2.6 Gallons</u>

Using a similar procedure for the distance to climb results in 18 nautical miles.

The resultant cruise distance is:

Total distance	360 Nautical Miles
Climb distance	<u>-18 Nautical Miles</u>
Cruise distance	342 Nautical Miles

(Continued Next Page)

## SAMPLE PROBLEM (Continued)

### FUEL REQUIRED (Continued)

With an expected 10 knot head wind, the ground speed for cruise is predicted to be:

$$\begin{array}{r} 117 \text{ Knots} \\ -10 \text{ Knots} \\ \hline 107 \text{ Knots} \end{array}$$

Therefore, the time required for the cruise portion of the trip is:

$$\frac{342 \text{ Nautical Miles}}{107 \text{ Knots}} = 3.2 \text{ Hours}$$

The fuel required for cruise is:

$$3.2 \text{ hours} \times 8.9 \text{ gallons/hour} = 28.5 \text{ Gallons}$$

A 45-minute reserve requires:

$$\frac{45}{60} \times 8.9 \text{ gallons/hour} = 6.7 \text{ Gallons}$$

The total estimated fuel required is as follows:

Engine start, taxi, and takeoff	1.4 Gallons
Climb	2.6 Gallons
Cruise	28.5 Gallons
Reserve	<u>6.7 Gallons</u>
Total fuel required	39.2 Gallons

Once the flight is underway, ground speed checks will provide a more accurate basis for estimating the time enroute and the corresponding fuel required to complete the trip with ample reserve.

(Continued Next Page)

## **SAMPLE PROBLEM** (Continued)

### **LANDING**

A procedure similar to takeoff should be used for estimating the landing distance at the destination airport. Figure 5-11 presents landing distance information for the short field technique. The distances corresponding to 2000 feet and 30°C are as follows:

Ground roll	650 Feet
Total distance to clear a 50-foot obstacle	1455 Feet

A correction for the effect of wind may be made based on information presented in the note section of the landing chart, using the same procedure as outlined for takeoff.

### **DEMONSTRATED OPERATING TEMPERATURE**

Satisfactory engine cooling has been demonstrated for this airplane with an outside air temperature 23°C above standard. This is not to be considered as an operating limitation. Reference should be made to Section 2 for engine operating limitations.





# TEMPERATURE CONVERSION CHART

B3093

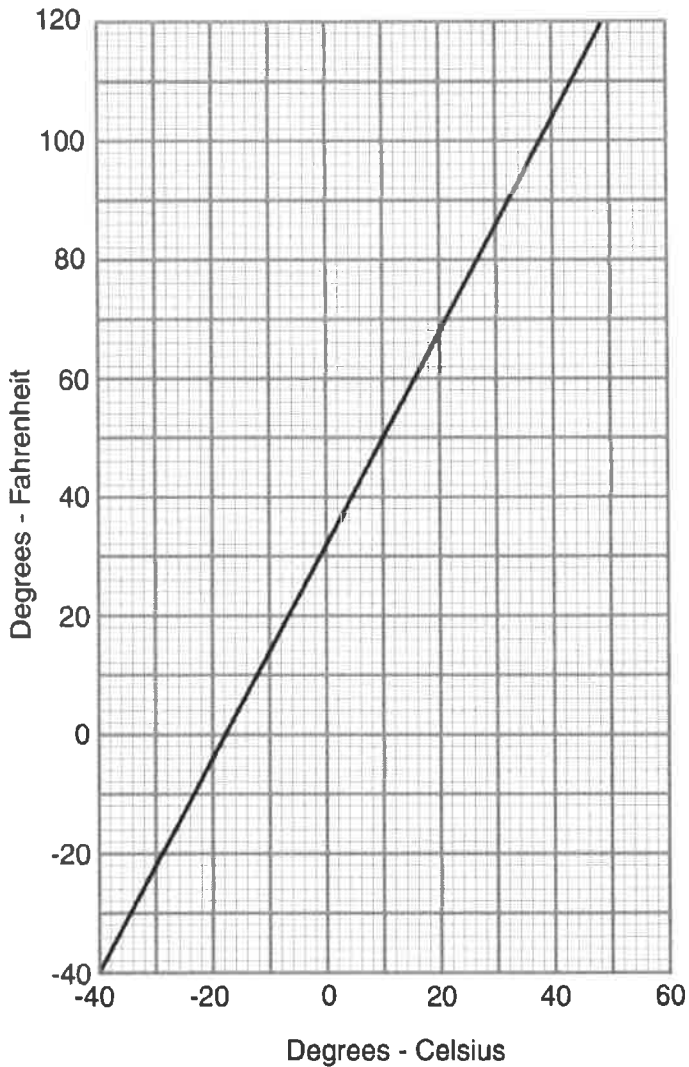

Figure 5-2

## STALL SPEED AT 2550 POUNDS

CONDITIONS:

Power IDLE

### MOST REARWARD CENTER OF GRAVITY

FLAP SETTINGS	ANGLE OF BANK							
	0°		30°		45°		60°	
	KIAS	KCAS	KIAS	KCAS	KIAS	KCAS	KIAS	KCAS
UP	48	53	52	57	62	63	76	75
10°	42	50	45	54	54	59	70	71
FULL	40	48	43	52	52	57	65	68

### MOST FORWARD CENTER OF GRAVITY

FLAP SETTINGS	ANGLE OF BANK							
	0°		30°		45°		60°	
	KIAS	KCAS	KIAS	KCAS	KIAS	KCAS	KIAS	KCAS
UP	48	53	52	57	61	63	76	75
10°	43	51	46	55	56	61	71	72
FULL	40	48	43	52	52	57	65	68

### NOTE

- Altitude loss during a stall recovery may be as much as 230 feet.
- KIAS values are approximate.

Figure 5-3\*

### CROSSWIND COMPONENT

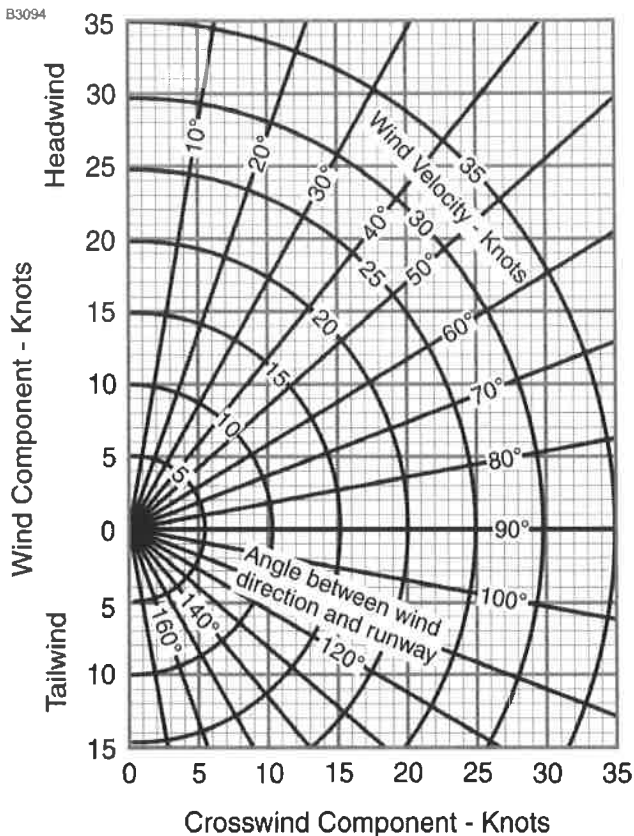

#### MAXIMUM DEMONSTRATED CROSSWIND VELOCITY

Takeoff, Flaps UP .....	20 KNOTS
Takeoff, Flaps 10° .....	20 KNOTS
Landing, Flaps 10° .....	20 KNOTS
Landing, Flaps FULL .....	15 KNOTS

Figure 5-4

## SHORT FIELD TAKEOFF DISTANCE AT 2550 POUNDS

**CONDITIONS:**

Flaps 10°

Full Throttle prior to brake release.

Paved, Level, Dry Runway

Zero Wind

Lift Off: 51 KIAS

Speed at 50 Feet: 56 KIAS

Pressure Altitude Feet	0°C		10°C		20°C		30°C		40°C	
	Gnd Roll Feet	Total Feet To Clear 50 Foot Obst	Gnd Roll Feet	Total Feet To Clear 50 Foot Obst	Gnd Roll Feet	Total Feet To Clear 50 Foot Obst	Gnd Roll Feet	Total Feet To Clear 50 Foot Obst	Gnd Roll Feet	Total Feet To Clear 50 Foot Obst
Sea Level	860	1465	925	1575	995	1690	1070	1810	1150	1945
1000	940	1600	1010	1720	1090	1850	1170	1990	1260	2135
2000	1025	1755	1110	1890	1195	2035	1285	2190	1380	2355
3000	1125	1925	1215	2080	1310	2240	1410	2420	1515	2605
4000	1235	2120	1335	2295	1440	2480	1550	2685	1660	2880
5000	1355	2345	1465	2545	1585	2755	1705	2975	1825	3205
6000	1495	2605	1615	2830	1745	3075	1875	3320	2010	3585
7000	1645	2910	1785	3170	1920	3440	2065	3730	2215	4045
8000	1820	3265	1970	3575	2120	3880	2280	4225	2450	4615

### NOTE

- Short field technique as specified in Section 4.
- Prior to takeoff from fields above 3000 feet pressure altitude, the mixture should be leaned to give maximum RPM in a full throttle, static run-up.
- Decrease distances 10% for each 9 knots head wind. For operation with tail winds up to 10 knots, increase distances by 10% for each 2 knots.
- For operation on dry grass runway, increase distances by 15% of the "ground roll" figure.

Figure 5-5 (Sheet 1 of 3)

## SHORT FIELD TAKEOFF DISTANCE AT 2400 POUNDS

**CONDITIONS:**

Flaps 10°

Full Throttle prior to brake release.

Paved, Level, Dry Runway

Zero Wind

Lift Off: 48 KIAS

Speed at 50 Feet: 54 KIAS

Pressure Altitude Feet	0°C		10°C		20°C		30°C		40°C	
	Gnd Roll Feet	Total Feet To Clear 50 Foot Obst	Gnd Roll Feet	Total Feet To Clear 50 Foot Obst	Gnd Roll Feet	Total Feet To Clear 50 Foot Obst	Gnd Roll Feet	Total Feet To Clear 50 Foot Obst	Gnd Roll Feet	Total Feet To Clear 50 Foot Obst
Sea Level	745	1275	800	1370	860	1470	925	1570	995	1685
1000	810	1390	875	1495	940	1605	1010	1720	1085	1845
2000	885	1520	955	1635	1030	1760	1110	1890	1190	2030
3000	970	1665	1050	1795	1130	1930	1215	2080	1305	2230
4000	1065	1830	1150	1975	1240	2130	1335	2295	1430	2455
5000	1170	2015	1265	2180	1360	2355	1465	2530	1570	2715
6000	1285	2230	1390	2410	1500	2610	1610	2805	1725	3015
7000	1415	2470	1530	2685	1650	2900	1770	3125	1900	3370
8000	1560	2755	1690	3000	1815	3240	1950	3500	2095	3790

### NOTE

- Short field technique as specified in Section 4.
- Prior to takeoff from fields above 3000 feet pressure altitude, the mixture should be leaned to give maximum RPM in a full throttle, static run-up.
- Decrease distances 10% for each 9 knots head wind. For operation with tail winds up to 10 knots, increase distances by 10% for each 2 knots.
- For operation on dry grass runway, increase distances by 15% of the "ground roll" figure.

Figure 5-5 (Sheet 2)

## SHORT FIELD TAKEOFF DISTANCE AT 2200 POUNDS

**CONDITIONS:**

Flaps 10°

Full Throttle prior to brake release.

Paved, Level, Dry Runway

Zero Wind

Lift Off: 44 KIAS

Speed at 50 Feet: 50 KIAS

Pressure Altitude Feet	0°C		10°C		20°C		30°C		40°C	
	Gnd Roll Feet	Total Feet To Clear 50 Foot Obst	Gnd Roll Feet	Total Feet To Clear 50 Foot Obst	Gnd Roll Feet	Total Feet To Clear 50 Foot Obst	Gnd Roll Feet	Total Feet To Clear 50 Foot Obst	Gnd Roll Feet	Total Feet To Clear 50 Foot Obst
Sea Level	610	1055	655	1130	705	1205	760	1290	815	1380
1000	665	1145	720	1230	770	1315	830	1410	890	1505
2000	725	1250	785	1340	845	1435	905	1540	975	1650
3000	795	1365	860	1465	925	1570	995	1685	1065	1805
4000	870	1490	940	1605	1010	1725	1090	1855	1165	1975
5000	955	1635	1030	1765	1110	1900	1195	2035	1275	2175
6000	1050	1800	1130	1940	1220	2090	1310	2240	1400	2395
7000	1150	1985	1245	2145	1340	2305	1435	2475	1540	2650
8000	1270	2195	1370	2375	1475	2555	1580	2745	1695	2950

**NOTE**

- Short field technique as specified in Section 4.
- Prior to takeoff from fields above 3000 feet pressure altitude, the mixture should be leaned to give maximum RPM in a full throttle, static run-up.
- Decrease distances 10% for each 9 knots head wind. For operation with tail winds up to 10 knots, increase distances by 10% for each 2 knots.
- For operation on dry grass runway, increase distances by 15% of the "ground roll" figure.

Figure 5-5 (Sheet 3)

**MAXIMUM RATE OF CLIMB  
AT 2550 POUNDS**

CONDITIONS:

Flaps UP  
Full Throttle

Pressure Altitude Feet	Climb Speed - KIAS	Rate of Climb - FPM			
		-20°C	0°C	20°C	40°C
Sea Level	74	855	785	710	645
2000	73	760	695	625	560
4000	73	685	620	555	495
6000	73	575	515	450	390
8000	72	465	405	345	285
10,000	72	360	300	240	180
12,000	72	255	195	135	---

**NOTE**

Mixture leaned above 3000 feet pressure altitude for maximum RPM.

Figure 5-6

## TIME, FUEL AND DISTANCE TO CLIMB AT 2550 POUNDS

**CONDITIONS:**

Flaps UP  
 Full Throttle  
 Standard Temperature

Pressure Altitude Feet	Temp °C	Climb Speed KIAS	Rate of Climb FPM	From Sea Level		
				Time Minutes	Fuel Used Gallons	Distance NM
Sea Level	15	74	730	0	0.0	0
1000	13	73	695	1	0.4	2
2000	11	73	655	3	0.8	4
3000	9	73	620	4	1.2	6
4000	7	73	600	6	1.5	8
5000	5	73	550	8	1.9	10
6000	3	73	505	10	2.2	13
7000	1	73	455	12	2.6	16
8000	-1	72	410	14	3.0	19
9000	-3	72	360	17	3.4	22
10,000	-5	72	315	20	3.9	27
11,000	-7	72	265	24	4.4	32
12,000	-9	72	220	28	5.0	38

**NOTE**

- Add 1.4 gallons of fuel for engine start, taxi and takeoff allowance.
- Mixture leaned above 3000 feet pressure altitude for maximum RPM.
- Increase time, fuel and distance by 10% for each 10°C above standard temperature.
- Distances shown are based on zero wind.

Figure 5-7

## CRUISE PERFORMANCE

CONDITIONS:

2550 Pounds

Recommended Lean Mixture

Pressure Altitude Feet	RPM	20°C BELOW STANDARD TEMP			STANDARD TEMPERATURE			20°C ABOVE STANDARD TEMP		
		%	KTAS	GPH	%	KTAS	GPH	%	KTAS	GPH
		MCP			MCP			MCP		
2000	2550	83	117	11.1	77	118	10.5	72	117	9.9
	2500	78	115	10.6	73	115	9.9	68	115	9.4
	2400	69	111	9.6	64	110	9.0	60	109	8.5
	2300	61	105	8.6	57	104	8.1	53	102	7.7
	2200	53	99	7.7	50	97	7.3	47	95	6.9
	2100	47	92	6.9	44	90	6.6	42	89	6.3
4000	2600	83	120	11.1	77	120	10.4	72	119	9.8
	2550	79	118	10.6	73	117	9.9	68	117	9.4
	2500	74	115	10.1	69	115	9.5	64	114	8.9
	2400	65	110	9.1	61	109	8.5	57	107	8.1
	2300	58	104	8.2	54	102	7.7	51	101	7.3
	2200	51	98	7.4	48	96	7.0	45	94	6.7
	2100	45	91	6.6	42	89	6.4	40	87	6.1
6000	2650	83	122	11.1	77	122	10.4	72	121	9.8
	2600	78	120	10.6	73	119	9.9	68	118	9.4
	2500	70	115	9.6	65	114	9.0	60	112	8.5
	2400	62	109	8.6	57	108	8.2	54	106	7.7
	2300	54	103	7.8	51	101	7.4	48	99	7.0
	2200	48	96	7.1	45	94	6.7	43	92	6.4

### NOTE

- Maximum cruise power using recommended lean mixture is 75% MCP. Power settings above 75% MCP are listed to aid interpolation. Operations above 75% MCP must use full rich mixture.
- Cruise speeds are shown for an airplane equipped with speed fairings. Without speed fairings, decrease speeds shown by 2 knots.

Figure 5-8 (Sheet 1 of 2)

## CRUISE PERFORMANCE

CONDITIONS:  
 2550 Pounds  
 Recommended Lean Mixture

Pressure Altitude Feet	RPM	20°C BELOW STANDARD TEMP			STANDARD TEMPERATURE			20°C ABOVE STANDARD TEMP		
		%			%			%		
		MCP	KTAS	GPH	MCP	KTAS	GPH	MCP	KTAS	GPH
8000	2700	83	125	11.1	77	124	10.4	71	123	9.7
	2650	78	122	10.5	72	122	9.9	67	120	9.3
	2600	74	120	10.0	68	119	9.4	64	117	8.9
	2500	65	114	9.1	61	112	8.6	57	111	8.1
	2400	58	108	8.2	54	106	7.8	51	104	7.4
	2300	52	101	7.5	48	99	7.1	46	97	6.8
	2200	46	94	6.8	43	92	6.5	41	90	6.2
10,000	2700	78	124	10.5	72	123	9.8	67	122	9.3
	2650	73	122	10.0	68	120	9.4	63	119	8.9
	2600	69	119	9.5	64	117	9.0	60	115	8.5
	2500	62	113	8.7	57	111	8.2	54	109	7.8
	2400	55	106	7.9	51	104	7.5	49	102	7.1
	2300	49	100	7.2	46	97	6.8	44	95	6.5
12,000	2650	69	121	9.5	64	119	8.9	60	117	8.5
	2600	65	118	9.1	61	116	8.5	57	114	8.1
	2500	58	111	8.3	54	109	7.8	51	107	7.4
	2400	52	105	7.5	49	102	7.1	46	100	6.8
	2300	47	98	6.9	44	95	6.6	41	92	6.3

### NOTE

- Maximum cruise power using recommended lean mixture is 75% MCP. Power settings above 75% MCP are listed to aid interpolation. Operations above 75% MCP must use full rich mixture.
- Cruise speeds are shown for an airplane equipped with speed fairings. Without speed fairings, decrease speeds shown by 2 knots.

Figure 5-8 (Sheet 2)

**RANGE PROFILE**  
**45 MINUTES RESERVE**  
**53 GALLONS USABLE FUEL**

CONDITIONS:  
2550 Pounds  
Recommended Lean Mixture for Cruise at all altitudes

Standard Temperature  
Zero Wind

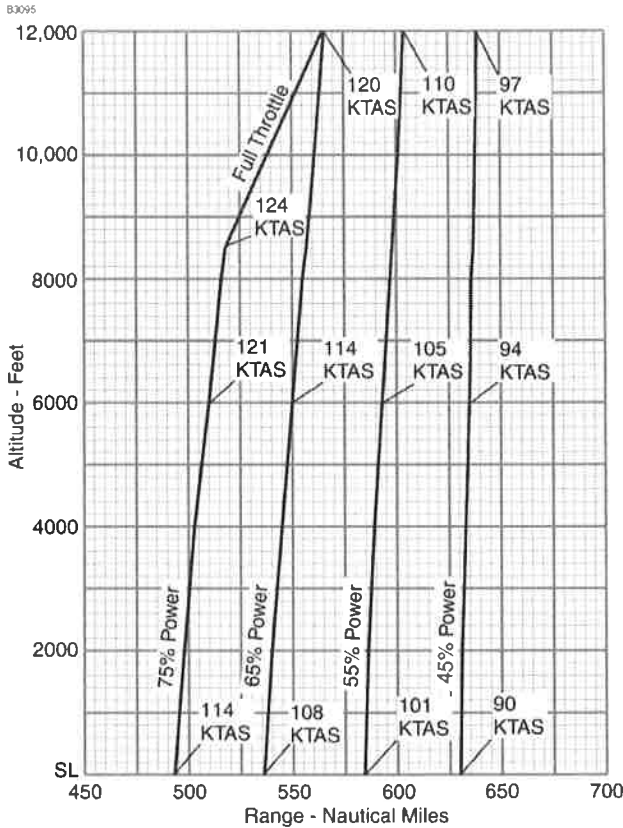

**NOTE**

- This chart allows for the fuel used for engine start, taxi, takeoff and climb, and the distance during a normal climb.
- Cruise speeds are shown for an airplane equipped with speed fairings. Without speed fairings, decrease speeds shown by 2 knots.

Figure 5-9

### ENDURANCE PROFILE 45 MINUTES RESERVE 53 GALLONS USABLE FUEL

CONDITIONS:  
2550 Pounds  
Recommended Lean Mixture for Cruise at all altitudes

Standard Temperature

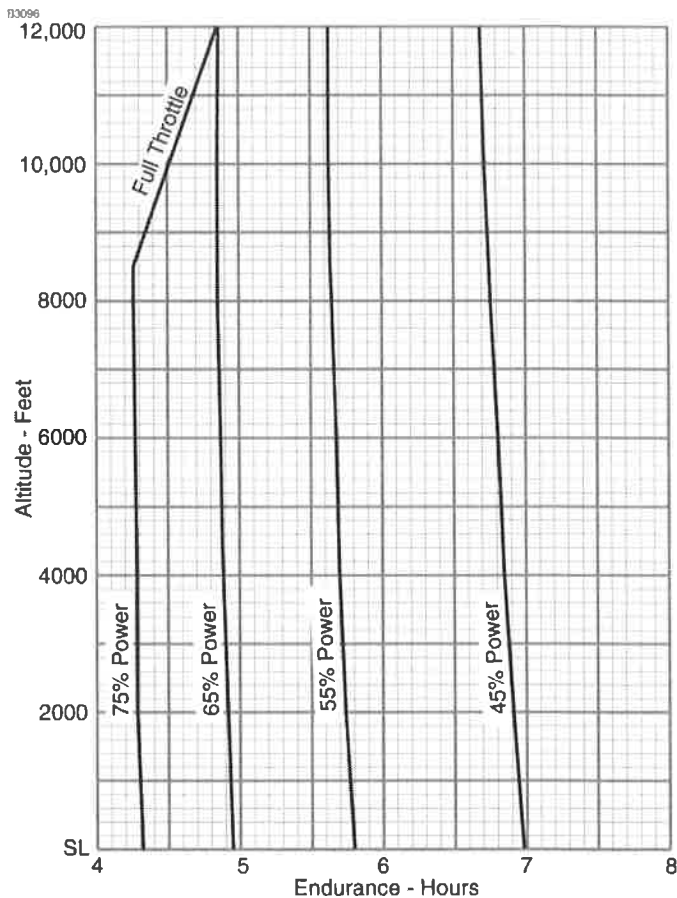

#### NOTE

This chart allows for the fuel used for engine start, taxi, takeoff and climb, and the time during a normal climb.

Figure 5-10

## SHORT FIELD LANDING DISTANCE AT 2550 POUNDS

**CONDITIONS:**

Flaps FULL  
Power IDLE  
Maximum Braking

Zero Wind  
Paved, Level, Dry Runway  
Speed at 50 ft: 61 KIAS

Pressure Altitude Feet	0°C		10°C		20°C		30°C		40°C	
	Gnd Roll Feet	Total Feet To Clear 50 Foot Obst	Gnd Roll Feet	Total Feet To Clear 50 Foot Obst	Gnd Roll Feet	Total Feet To Clear 50 Foot Obst	Gnd Roll Feet	Total Feet To Clear 50 Foot Obst	Gnd Roll Feet	Total Feet To Clear 50 Foot Obst
Sea Level	545	1290	565	1320	585	1350	605	1380	625	1415
1000	565	1320	585	1350	605	1385	625	1420	650	1450
2000	585	1355	610	1385	630	1420	650	1455	670	1490
3000	610	1385	630	1425	655	1460	675	1495	695	1530
4000	630	1425	655	1460	675	1495	700	1535	725	1570
5000	655	1460	680	1500	705	1535	725	1575	750	1615
6000	680	1500	705	1540	730	1580	755	1620	780	1660
7000	705	1545	730	1585	760	1625	785	1665	810	1705
8000	735	1585	760	1630	790	1670	815	1715	840	1755

**NOTE**

- Short field technique as specified in Section 4.
- Decrease distances 10% for each 9 knots head wind. For operation with tail winds up to 10 knots, increase distances by 10% for each 2 knots.
- For operation on dry grass runway, increase distances by 45% of the "ground roll" figure.
- If landing with flaps up, increase the approach speed by 9 KIAS and allow for 35% longer distances.

Figure 5-11

## WEIGHT AND BALANCE/ EQUIPMENT LIST

### TABLE OF CONTENTS

	Page
Introduction . . . . .	6-3
Airplane Weighing Procedures . . . . .	6-3
Airplane Weighing Form . . . . .	6-5
Sample Weight and Balance Record . . . . .	6-7
Weight And Balance . . . . .	6-8
Baggage Tiedown . . . . .	6-9
Sample Loading Problem . . . . .	6-10
Loading Graph . . . . .	6-12
Loading Arrangements . . . . .	6-13
Internal Cabin Dimensions . . . . .	6-14
Center Of Gravity Moment Envelope . . . . .	6-15
Center of Gravity Limits . . . . .	6-16
Comprehensive Equipment List . . . . .	6-17/6-18



## INTRODUCTION

This section describes the procedure for establishing the basic empty weight and moment of the airplane. Sample forms are provided for reference. Procedures for calculating the weight and moment for various operations are also provided. For additional information regarding Weight and Balance procedures, refer to the Aircraft Weight and Balance Handbook (FAA-H-8083-1). A comprehensive list of Cessna equipment available for this airplane is included at the back of this section.

Specific information regarding the weight, arm, moment and installed equipment for this airplane as delivered from the factory can be found in the plastic envelope in the back of this POH.

### WARNING

**IT IS THE RESPONSIBILITY OF THE PILOT TO MAKE SURE THE AIRPLANE IS LOADED PROPERLY. OPERATION OUTSIDE OF PRESCRIBED WEIGHT AND BALANCE LIMITATIONS COULD RESULT IN AN ACCIDENT AND SERIOUS OR FATAL INJURY.**

## AIRPLANE WEIGHING PROCEDURES

1. Preparation:
  - a. Inflate tires to recommended operating pressures.
  - b. Defuel airplane. Refer to the Maintenance Manual.
  - c. Service engine oil as required to obtain a normal full indication (approximately 7 quarts on dipstick).
  - d. Move sliding seats to the most forward position.
  - e. Raise flaps to the fully retracted position.
  - f. Place all control surfaces in neutral position.
  - g. Remove all non-required items from airplane.

(Continued Next Page)

## AIRPLANE WEIGHING PROCEDURES (Continued)

2. Level:
  - a. Place scales under each wheel (minimum scale capacity, 1000 pounds).
  - b. Deflate the nose tire and/or lower or raise the nose strut to properly center the bubble in the level (Refer to Figure 6-1 Sheet 1).
3. Weigh:
  - a. Weigh airplane in a closed hangar to avoid errors caused by air currents.
  - b. With the airplane level and brakes released, record the weight shown on each scale. Deduct the tare, if any, from each reading.
4. Measure:
  - a. Obtain measurement A by measuring horizontally (along the airplane centerline) from a line stretched between the main wheel centers to a plumb bob dropped from the firewall.
  - b. Obtain measurement B by measuring horizontally and parallel to the airplane centerline, from center of nosewheel axle, left side, to a plumb bob dropped from the line between the main wheel centers. Repeat on right side and average the measurements.
5. Using weights from step 3 and measurements from step 4, the Basic Empty Weight and C.G. can be determined by completing Figure 6-1 (Sheet 2).
6. Changes to the Airplane Weight and Balance due to alteration or repair must be documented in a permanent record within the POH similar to that shown in Figure 6-2.
7. A new Basic Empty Weight and CG Arm based on actual airplane weight (as weighed) is required after a major repair or alteration. It is recommended that the airplane be weighed to verify Basic Empty Weight and CG Arm at intervals not to exceed 5 years.

### AIRPLANE WEIGHING FORM

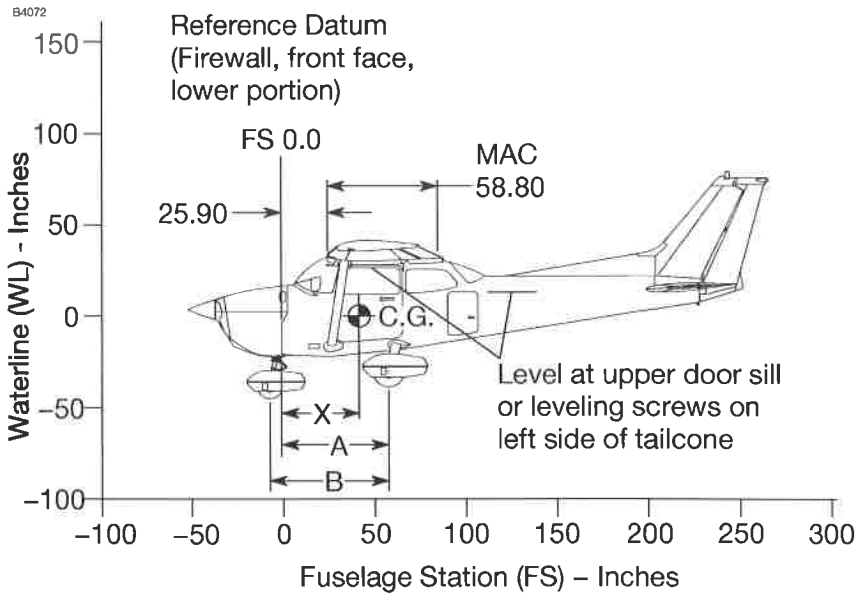

#### NOTE

It is the responsibility of the pilot to make sure that the airplane is loaded properly.

0510T1005

Figure 6-1 (Sheet 1 of 2)

## AIRPLANE WEIGHING FORM

B4073

### Locating CG with Airplane on Landing Gear

$$X \text{ (Inches Aft of Datum)} = A - \left[ \frac{\text{Nosewheel Weight} \times B}{\text{Total Weight}^*} \right]$$

### Locating Percent MAC

\*(Nose + L + R Wheel Weights)

$$\text{CG Percent MAC} = \frac{(\text{CG Arm of Airplane}) - 25.90}{0.5880}$$

### Measuring A and B

Measure A and B per pilot's operating handbook instructions to assist in locating CG with airplane weighed on landing gear.

### Leveling Provisions

Longitudinal – Left side of tailcone at FS 108.00 and 142.00

### Airplane as Weighed Table

Position	Scale reading	Scale drift	Tare	Net weight
Left Wheel				
Right Wheel				
Nose Wheel				
Airplane total as weighed				

### Basic Empty Weight and Center-of-Gravity Table

Item	Weight Pounds	CG Arm (Inches)	Moment (Inch-Pounds /1000)
Airplane (calculated or as weighed) (includes all undrainable fluids and full oil)			
Drainable unusable fuel at 6.0 pounds per gallon – (3 gallons)	18.0	46.00	0.83
Basic Empty Weight			

Figure 6-1 (Sheet 2)

# WEIGHT & BALANCE AND INSTALLED EQUIPMENT DATA

CESSNA AIRCRAFT COMPANY  
SINGLE ENGINE DIVISION



MODEL	SERIAL & REGISTRATION		WEIGHT	ARM	MOMENT
172S	172S10773	N6196H	(lbs)	(in)	(lb-in)
(calculated)	STANDARD EMPTY WEIGHT		1,702.2	41.011	69,809
INSTALLED EQUIPMENT			Net Change from Standard Aircraft		
BAGGAGE NET			0.0	0.000	0
FUEL SAMPLING CUP			0.0	0.000	0
PILOTS CHECKLIST			0.0	0.000	0
OH AND FAA APPROVED AIRPLANE FLIGHT MANUAL			0.0	0.000	0
TOW BAR, NOSE GEAR (STOWED)			0.0	0.000	0
AIRSPEED INDICATOR			0.0	0.000	0
ALTIMETER WITH 20 FT MARKING, DUAL WINDOW, 20000 FT			0.0	0.000	0
RTX 2 FREQUENCY ELT (STANDARD EQUIPMENT)			0.0	0.000	0
ATTITUDE INDICATOR			0.0	0.000	0
COMPONENTS REQUIRED FOR FRONT SEAT INFLATABLE RESTRAINT			0.3	45.300	14
ENGINE, LYCOMING IO-360-L2A			0.0	0.000	0
DL-69A WEATHER DATALINK RECEIVER			4.0	47.000	188
FC-700 AUTOPILOT			6.9	139.600	963
ROPELLER ASSY, MCCAULEY, FIXED PITCH, 1A170E/JHA7660			0.0	0.000	0
TC SA01700LA FRONT SEAT INFLATABLE RESTRAINT SYSTEM			3.8	45.300	172
VINYL/LEATHER SEATS			0.0	0.000	0
HEEL FAIRING INSTALLATION			16.5	46.100	761
FIRE EXTINGUISHER INSTALLATION			0.0	0.000	0
INTERIOR INSTALLATION			0.0	0.000	0

The weight and balance data shown in this report are computed on the basis of Federal Aviation Administration approved procedures for establishing fleet weight averages. [Far 21.327(f)(2)]

Weighed: 06/25/2008  
Printed: 08/11/2008

This list contains all installed equipment and avionics. All weights and arms are the installed weights and arms from a standard equipped aircraft. For a detailed list of aircraft equipment weight and balance data, please refer to the comprehensive equipment list in the pilots operating book.

BASIC EMPTY WEIGHT	1,733.7	41.476	71,907
USEFUL LOAD	824.3	 ODARF100129CE	
MAXIMUM RAMP WEIGHT	2,558.0		
MAXIMUM TAKE-OFF WEIGHT	2,550.0		

Revised 27 Aug. 2005

Numerical values shown may be rounded from actual values. Therefore, the product of weight times arm may not equal the listed values. Therefore, the product of weight times arm may not equal the listed moment.



AAC AUSTRIAN AIRCRAFT CORPORATION	Wiegebericht <i>Amendment</i> Luftfahrzeugart: <i>LFZ</i>	Kennzeichen: <i>OE-DCL</i>
---	---	----------------------------

Baumuster: *Cessna 172 S*  
 Werk Nr. *17251073*  
 Bezugspunkt: *Firewall, front face, lower portion*   
 Bezugsebene: *-*  
 Angaben aufgrund: *-*

Wiegezustand: Ausrüstungsverzeichnis vom: */*      Triebwerksöl: */*  
 Treibstoff: */*      Sonstiges:

Wiegung:	Wiegepunkt	Abgelesenes Gewicht kg / lbs	Tara kg / lbs	Nettogewicht kg / lbs	Arm in	Moment kg / in lb
	links	/		/		/
	rechts	/		/		/
	Bug/Heck	/		/		/
<b>Gesamtgewicht laut Wiegung:</b>						
	Nichtausfliegbare Treibstoff:					
	Triebwerksöl:					
	Ausfliegbare Treibstoff			/		/

**Leergewicht laut Wiegung vom:** *01.10.08*      *1743,5*      *41,53*      *72,408*

Gewichtsberichtigung	Gewichtsänderung lt. Bericht vom:			
	<i>Fire Extinguisher removed</i>	<i>-4,6</i>	<i>45,3</i>	<i>208,38</i>

**Leergewicht lt. Gewichtsberichtigung vom:** *08.01.26*      *1738,9*      *41,52*      *72.199,62*

Luftfahrzeug Kategorie	
Verwendungsart	
Einsatzart	
Aktuelles Leergewicht	<i>1738,9 lbs</i>
Zuladung	<i>811,1 lbs</i>
Maximales Abflug-/Landegewicht	<i>2550 lbs</i>

*LOAV / 08.01.26*  
 Ort und Datum der Wiegung/ Berichtigung

*[Signature]*  
 Unterschrift

**AAC VÖSLAU**  
 CA 67636  
 Schimpl  
 AT-CAO-017

## WEIGHT AND BALANCE

The following information will enable you to operate your Cessna within the prescribed weight and center of gravity limitations. To determine weight and balance, use the Sample Loading Problem (Figure 6-3), Loading Graph (Figure 6-4), and Center of Gravity Moment Envelope (Figure 6-7) as follows:

Enter the appropriate basic empty weight and moment/1000 from the weight and balance records for your airplane in the YOUR AIRPLANE column of the Sample Loading Problem.

### NOTE

In addition to the basic empty weight and moment noted on these records, the C.G. arm (FS) is also shown, but need not be used on the Sample Loading Problem. The moment which is shown must be divided by 1000 and this value used as the moment/1000 on the loading problem.

Use the Loading Graph to determine the moment/1000 for each additional item to be carried; then list these on the loading problem.

### NOTE

Loading Graph information for the pilot, passengers and baggage is based on seats positioned for average occupants and baggage loaded in the center of the baggage areas as shown on the Loading Arrangements diagram. For loadings which may differ from these, the Sample Loading Problem lists fuselage stations (FS) for these items to indicate their forward and aft C.G. range limitations (seat travel and baggage area limitation). Refer to Figures 6-5 and 6-6 for additional loading information. Additional moment calculations, based on the actual weight and C.G. arm (FS) of the item being loaded, must be made if the position of the load is different from that shown on the Loading Graph.

Total the weights and moments/1000 and plot these values on the Center of Gravity Moment Envelope to determine whether the point falls within the envelope, and if the loading is acceptable.

(Continued Next Page)

## **WEIGHT AND BALANCE** (Continued)

### **BAGGAGE TIEDOWN**

A nylon baggage net having four tiedown straps is provided as standard equipment to secure baggage on the cabin floor aft of the rear seat (baggage area A) and in the aft baggage area (baggage area B). Six eyebolts serve as attaching points for the net. Two eyebolts for the forward tiedown straps are mounted on the cabin floor near each sidewall just forward of the baggage door approximately at station FS 90; two eyebolts are installed on the cabin floor slightly inboard of each sidewall approximately at FS 107; and two eyebolts are located below the aft window near each sidewall approximately at FS 107. A placard on the baggage door defines the weight limitations in the baggage areas.

When baggage area A is utilized for baggage only, the two forward floor mounted eyebolts and the two aft floor mounted eyebolts (or the two eyebolts below the aft window) may be used, depending on the height of the baggage. When baggage is carried in the baggage area B only, the aft floor mounted eyebolts and the eyebolts below the aft window should be used. When baggage is loaded in both areas, all six eyebolts should be utilized.

### SAMPLE LOADING PROBLEM

ITEM DESCRIPTION	WEIGHT AND MOMENT TABULATION			
	SAMPLE AIRPLANE		YOUR AIRPLANE	
	Weight (lbs)	Moment (lb-ins/1000)	Weight (lbs)	Moment (lb-ins/1000)
1 - Basic Empty Weight (Use the data pertaining to your airplane as it is presently equipped. Includes unusable fuel and full oil)	1642	62.6		
2 - Usable Fuel (At 6 Lbs./Gal.)				
- Standard Fuel - 53 Gallons Maximum				
- Reduced Fuel - 35 Gallons	210	10.1		
3 - Pilot and Front Passenger (FS 34 to 46)	340	12.6		
4 - Rear Passengers (FS 73)	310	22.6		
5 - *Baggage "A" (FS 82 to 108) 120 Pounds Maximum	56	5.3		
6 - *Baggage "B" (FS 108 to 142) 50 Pounds Maximum				
<b>7 - RAMP WEIGHT AND MOMENT</b>	<b>2558</b>	<b>113.2</b>		
8 - Fuel allowance for engine start, taxi and runup	-8.0	-0.4		
<b>9 - TAKEOFF WEIGHT AND MOMENT</b> (Subtract Step 8 from Step 7)	<b>2550</b>	<b>112.8</b>		

10 - Locate this point (2550 at 112.8) on the Center of Gravity Moment Envelope, and since this point falls within the envelope, the loading is acceptable.

\*The maximum allowable combined weight capacity for baggage in areas "A" and "B" is 120 pounds.

Figure 6-3 (Sheet 1 of 2)





## LOADING ARRANGEMENTS

B4075

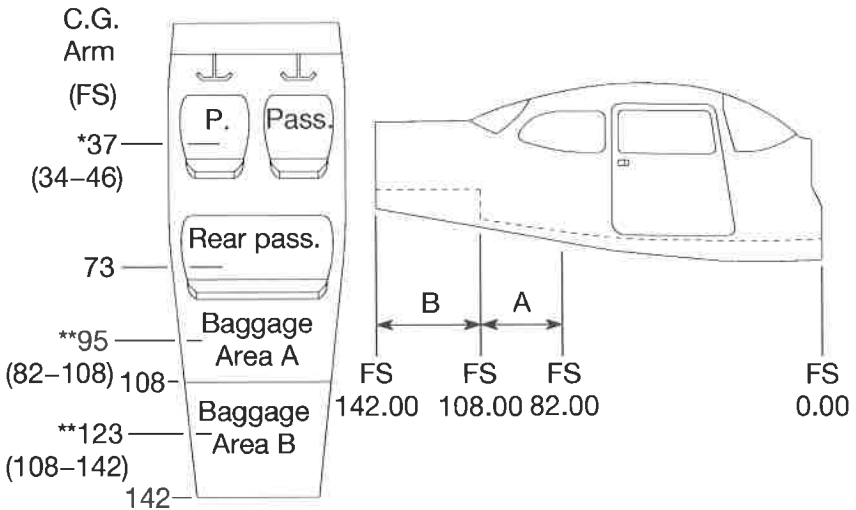

0585T1016

\*Pilot and front seat passenger center of gravity on adjustable seats positioned for average occupant. Numbers in parentheses indicate forward and aft limits of occupant center of gravity range.

\*\*Arm measured to the center of the areas shown.

### NOTE

- The usable fuel C.G. arm is located at FS 48.00.
- The aft baggage wall (approximate FS 108.00) or aft baggage wall (approximate FS 142.00) can be used as a convenient interior reference point for determining the location of baggage area fuselage stations.
- To achieve an airplane loading within the utility category, it may be necessary to remove the rear passenger seat assembly from the airplane. Refer to Figure 6-9 for applicable weight and arm.

Figure 6-5

## INTERNAL CABIN DIMENSIONS

B4076

### Cabin Height Measurements

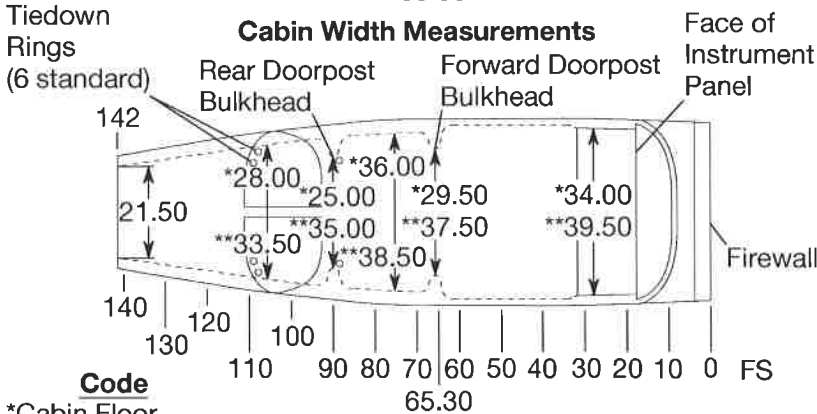
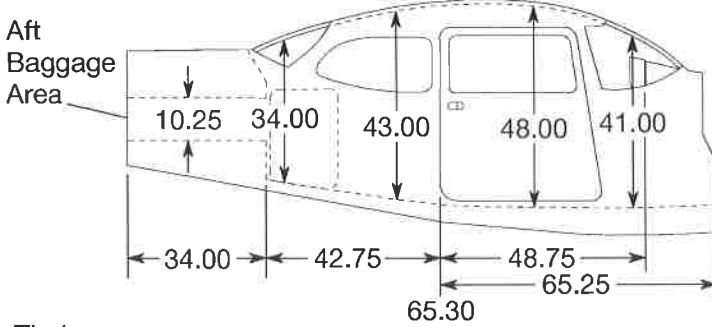

### Code

\*Cabin Floor

\*\*Lower Window Line

### Door Opening Dimensions

	Width (Top)	Width (Bottom)	Height (Front)	Height (Rear)
Cabin Door	32.00	37.00	40.50	39.00
Baggage Door	15.25	15.25	22.00	21.00

0585T1023  
0585T1004

### NOTE

- Maximum allowable floor loading is 200 pounds per square foot.
- All dimensions shown are in inches.

Figure 6-6

### CENTER OF GRAVITY MOMENT ENVELOPE

B4077

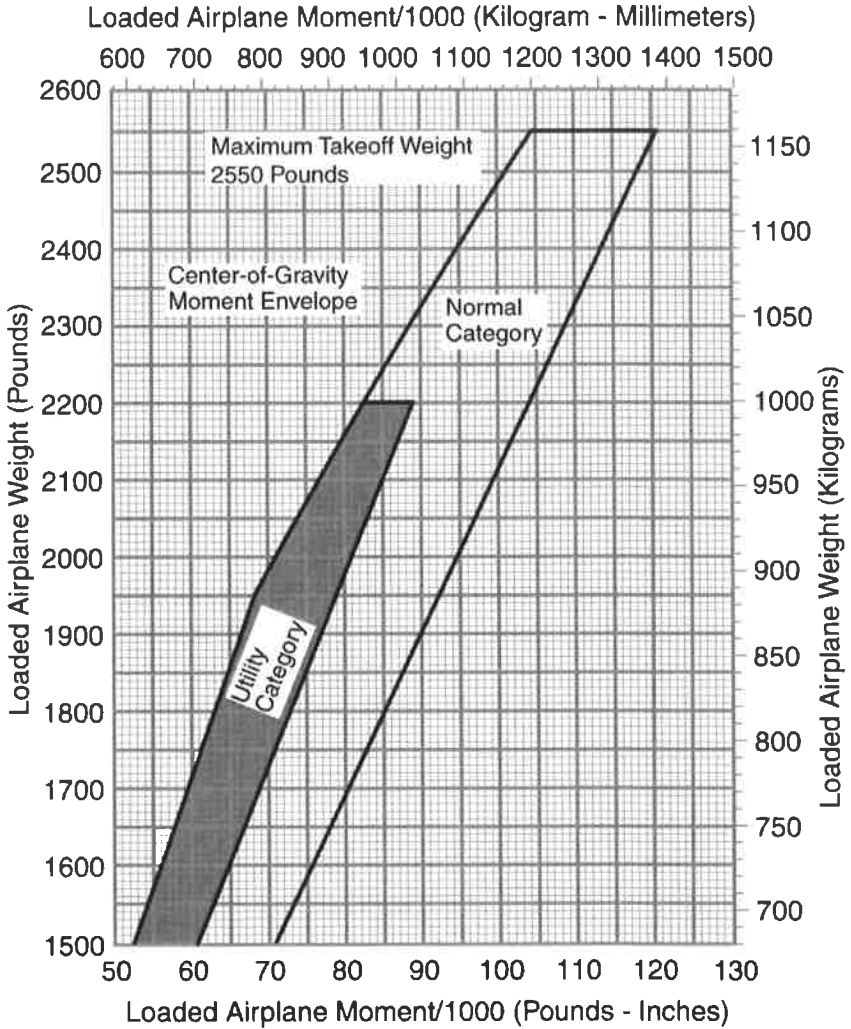

Figure 6-7

### CENTER OF GRAVITY LIMITS

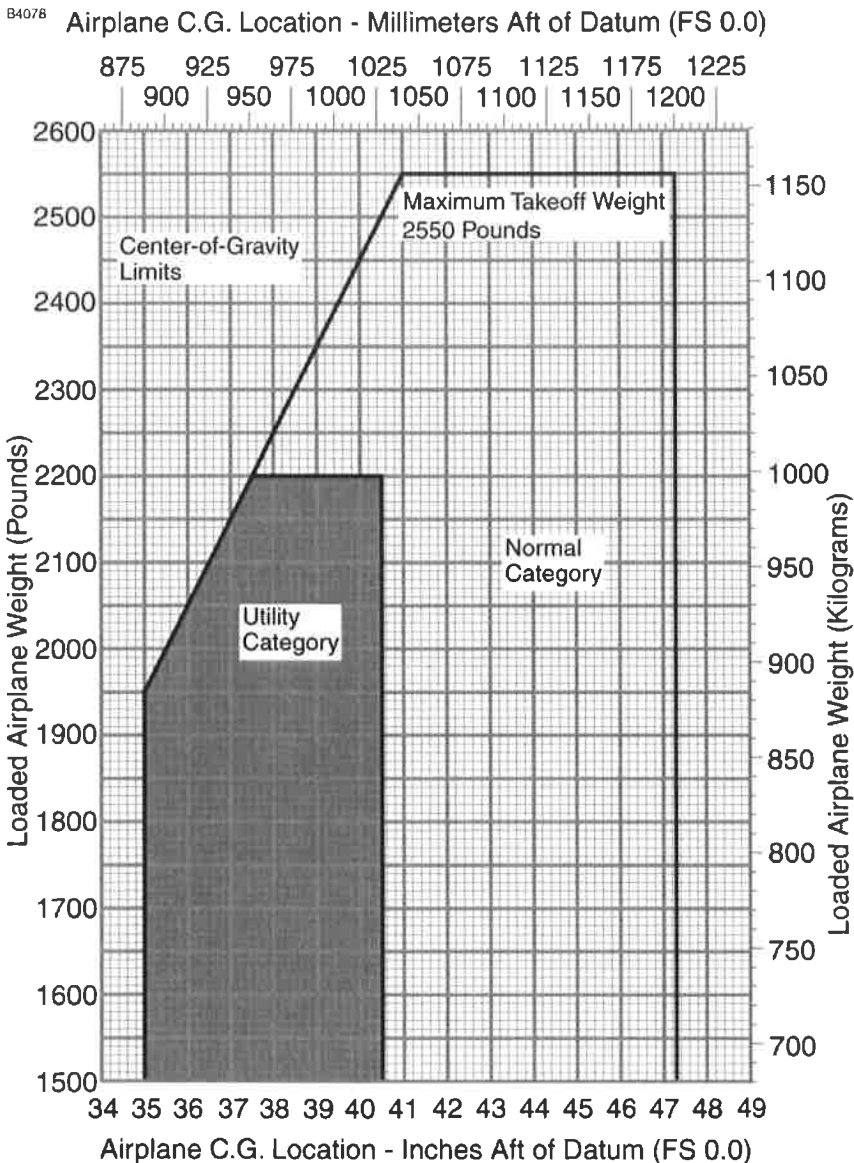

Figure 6-8

## COMPREHENSIVE EQUIPMENT LIST

Figure 6-9 is a comprehensive list of all Cessna equipment which is available for the Model 172S airplane equipped with Garmin G1000 Integrated Cockpit System and GFC 700 Autopilot (if installed) (Serials 172S10468, 172S10507, 172S10640 and 172S10656 and On). This comprehensive equipment list provides the following information in column form:

In the **ITEM NO** column, each item is assigned a coded number. The first two digits of the code represent the identification of the item within Air Transport Association Specification 100 (11 for Paint and Placards; 24 for Electrical Power; 77 for Engine Indicating, etc.). These assignments also correspond to the Maintenance Manual chapter for the airplane. After the first two digits, items receive a unique sequence number (01, 02, 03, etc.). After the sequence number, a suffix letter is assigned to identify equipment as a required item, a standard item or an optional item.

Suffix letters are as follows:

- R = Required items or equipment for FAA certification (14 CFR 23 or 14 CFR 91).
- S = Standard equipment items.
- O = Optional equipment items replacing required or standard items.
- A = Optional equipment items which are in addition to required or standard items.

In the **EQUIPMENT LIST DESCRIPTION** column, each item is assigned a descriptive name to help identify its function.

In the **REF DRAWING** column, a Cessna drawing number is provided which corresponds to the item.

### NOTE

If additional equipment is to be installed, it must be done in accordance with the reference drawing, service bulletin or a separate FAA approval.

In the **WT LBS** and **ARM INS** columns, information is provided on the weight (in pounds) and arm (in inches) of the equipment item.

### NOTE

- Unless otherwise indicated, true values (not net change values) for the weight and arm are shown. Positive arms are distances aft of the airplane datum; negative arms are distances forward of the datum.
- Asterisks (\*) in the weight and arm column indicate complete assembly installations. Some major components of the assembly are listed on the lines immediately following. The sum of these major components does not necessarily equal the complete assembly installation.



ITEM NO	EQUIPMENT LIST DESCRIPTION	REF DRAWING	WT LBS	ARM INS.
<b>11 - PAINT AND PLACARDS</b>				
11-01-S	PAINT, OVERALL WHITE WITH COLOR STRIPE - OVERALL WHITE COLOR - COLOR STRIPING	0500531	19.2* 18.4 0.8	95.4* 91.5 135.9
<b>21 - AIR CONDITIONING</b>				
21-01-S	VENTILATORS, ADJUSTABLE, CABIN AIR	0513575-2	1.7	60.0
21-02-S	CABIN HEATER SYSTEM, SHROUDED MUFFLER TYPE	0550365	2.5	-20.75
21-03-R	FORWARD AVIONICS COOLING FAN - MC24B3	3930379	0.5	12.4
21-04-R	AFT AVIONICS COOLING FAN	3940397	1.1	109.5
<b>22 - AUTO FLIGHT</b>				
22-01-O	GFC 700 AUTOPILOT INSTALLATION - PITCH/TRIM SERVOS - ROLL SERVO - AVIONICS CABLE ASSEMBLY (EXCHANGE) - REMOTE AVIONICS EQUIPMENT (EXCHANGE) - FIS ANTENNA	 3940475-1 3940480-1 3900079-4 3940397-2 3960233-1	19.8* 8.1 4.2 4.4 2.4 0.4	122.9 180.7 59.5 88.2 112.7 43.5
<b>23 - COMMUNICATIONS</b>				
23-01-S	STATIC DISCHARGE WICKS, (SET OF 10)	0501048-1	0.4	143.2
23-02-R	AUDIO/INTERCOM/MARKER BEACON - GMA 1347 AUDIO PANEL - CI-102 MARKER BEACON ANTENNA	 3930377 3960188	 1.7 0.5	 16.3 129.0
23-03-R	NAV/COM/GPS #1 COMPUTER - GIA 63W INTEGRATED AVIONICS UNIT - CI 2580-200 VHF COMM/GPS ANTENNA	 3921165 3940397 3960220	  5.2 0.5	  113.3 61.2
23-04-S	NAV/COM/GPS #2 COMPUTER - GIA 63W INTEGRATED AVIONICS UNIT - CI 2580-200 VHF COMM/GPS ANTENNA - CI 420-10 XM ANTENNA	 3921165 3940397 3960220 3960233	  5.2 0.5 0.5	  113.3 61.2 43.5
<b>24 - ELECTRICAL POWER</b>				
24-01-R	ALTERNATOR, 28 VOLT, 60 AMP, -9910591-11	0550365	10.0	-29.0
24-02-R	BATTERY, 24 VOLT, 8.0 AMP HOUR	0518034	23.2	-5.0
24-03-R	POWER DISTRIBUTION MODULE - S3100-366 - ALTERNATOR CONTROL UNIT - AC2101 - MASTER CONTACTOR - X61-0007 - STARTER CONTACTOR - X61-0027 - AMMETER TRANSDUCER - CS3200	 0518034 0518034 0518034 0518034 0518034	 6.4* 0.2 0.7 0.7 0.1	 -2.5* -2.5 -2.5 -2.5 -2.0
24-04-S	BATTERY, STANDBY - AVT 200413	0518025	14.0	11.2

Figure 6-9 (Sheet 1 of 6)

SECTION 6  
WEIGHT AND BALANCE/  
EQUIPMENT LIST

CESSNA  
MODEL 172S NAV III  
GFC 700 AFCS

ITEM NO	EQUIPMENT LIST DESCRIPTION	REF DRAWING	WT LBS	ARM INS.
<b>25 - EQUIPMENT/FURNISHINGS</b>				
25-01-R	SEAT, PILOT, ADJUSTABLE, LEATHER/VINYL COVER	0719025-4	33.0	41.5
25-02-S	SEAT, FRONT PASSENGER, ADJUSTABLE, LEATHER/VINYL COVER	0719025-4	33.0	41.5
25-03-S	SEAT, REAR PASSENGER, ONE-PIECE BACK, LEATHER/VINYL COVER	0519101-1	38.7	79.5
25-04-O	SEAT, REAR OBSERVER, ADJUSTABLE, LEATHER/VINYL COVER	0519109-2	27.9	72.5
25-07-R	SEAT BELT AND SHOULDER HARNESS, INERTIA REEL, AUTO ADJUST, PILOT AND FRONT PASSENGER	0519031-1	5.2	54.0
25-08-S	SEAT BELT AND SHOULDER HARNESS, INERTIA REEL, AUTO ADJUST, REAR SEAT	0519031-1	5.2	90.0
25-09-S	SUN VISOR (SET OF 2)	0514166-2	1.1	32.8
25-10-S	BAGGAGE RESTRAINT NET	2015009-7	0.5	95.0
25-11-S	CARGO TIEDOWN RINGS (SET OF 6)	0515055-6	0.2	95.0
25-12-S	TOW BAR, NOSE GEAR (STOWED)	0501019-1	1.7	124.0
25-13-R	PILOT'S OPERATING HANDBOOK AND FAA APPROVED AIRPLANE FLIGHT MANUAL (STOWED IN FRONT PASSENGER'S SEAT BACK)	0500832-1	1.2	50.0
25-14-R	GARMIN G1000 COCKPIT REFERENCE GUIDE (STOWED IN COCKPIT SIDE PANEL POCKET)		1.5	15.0
25-15-O	APPROACH PLATE HOLDER	0519107-1	0.1	22.0
25-16-S	FUEL SAMPLING CUP	S2107-1	0.1	14.3
25-17-S	ARTEX ME406 - 2 FREQUENCY ELT	3940458-1	2.6*	134.6*
	- ELT TRANSMITTER	ME406	2.1	135.5
	- ANTENNA AND CABLE ASSY	110-338	0.5	130.0
25-18-O	ARTEX C406-N - 3 FREQUENCY ELT	3940460-1	5.1*	135.0*
	- ELT TRANSMITTER	C406-N	4.6	135.5
	- ANTENNA AND CABLE ASSY	110-338	0.5	130.0

Figure 6-9 (Sheet 2)

TEMPORARY REVISION FOR CESSNA PILOT'S OPERATING HANDBOOK  
AND FAA APPROVED AIRPLANE FLIGHT MANUAL

Publication Affected: Model 172S Nav III (GFC 700), Serials 172S10468, 172S10507, 172S10640 and 172S10656 and On, basic Pilot's Operating Handbook and FAA Approved Airplane Flight Manual, Revision 4, dated 11 June 2021.

Airplane Serial Numbers Affected: Airplanes 172S10468, 172S10507, 172S10640 and 172S10656 and On.

Description of Change: Section 6, Weight and Balance/Equipment List, Comprehensive Equipment List, page 6-20, update the list of 25 - Equipment/Furnishings.

Filing Instructions: Insert this temporary revision in the Model 172S Nav III (GFC 700), Serials 172S10468, 172S10507, 172S10640 and 172S10656 and On, Pilot's Operating Handbook and FAA Approved Airplane Flight Manual adjacent to page 6-20.

Removal Instructions: This temporary revision must be removed and discarded when Revision 5 has been collated into the basic Pilot's Operating Handbook and FAA Approved Airplane Flight Manual.

---

In Section 6, Weight and Balance/Equipment List, Comprehensive Equipment List, page 6-20, replace figure 6-9 (Sheet 2), with the updated list of 25 - Equipment/Furnishings as shown on the opposite page:

APPROVED BY Mark Fuller

for

Stephen Gielisch, Lead ODA Administrator  
Textron Aviation Inc.  
Organization Delegation Authorization ODA-100129-CE  
FAA Approved Under 14 CFR Part 183 Subpart D

DATE OF APPROVAL 28 Oct. 2021

FAA APPROVED  
172SPHBUS-04 TR01

**TEMPORARY REVISION FOR CESSNA PILOT'S OPERATING HANDBOOK  
AND FAA APPROVED AIRPLANE FLIGHT MANUAL**

<b>ITEM NO</b>	<b>EQUIPMENT LIST DESCRIPTION</b>	<b>REF DRAWING</b>	<b>WT LBS</b>	<b>ARM INS.</b>
<b>25 - EQUIPMENT/FURNISHINGS</b>				
25-01-R	SEAT, PILOT, ADJUSTABLE, LEATHER/VINYL COVER	0719025-4	33.0	41.5
25-02-S	SEAT, FRONT PASSENGER, ADJUSTABLE, LEATHER/VINYL COVER	0719025-4	33.0	41.5
25-03-S	SEAT, REAR PASSENGER, ONE-PIECE BACK, LEATHER/VINYL COVER	0519101-1	38.7	79.5
25-04-O	SEAT, REAR OBSERVER, ADJUSTABLE, LEATHER/VINYL COVER	0519109-2	27.9	72.5
25-07-R	SEAT BELT AND SHOULDER HARNESS, INERTIA REEL, AUTO ADJUST, PILOT AND FRONT PASSENGER	0519031-1	5.2	54.0
25-08-S	SEAT BELT AND SHOULDER HARNESS, INERTIA REEL, AUTO ADJUST, REAR SEAT	0519031-1	5.2	90.0
25-09-S	SUN VISOR (SET OF 2)	0514166-2	1.1	32.8
25-10-S	BAGGAGE RESTRAINT NET	2015009-7	0.5	95.0
25-11-S	CARGO TIEDOWN RINGS (SET OF 6)	0515055-6	0.2	95.0
25-12-S	TOW BAR, NOSE GEAR (STOWED)	0501019-1	1.7	124.0
25-13-R	PILOT'S OPERATING HANDBOOK AND FAA APPROVED AIRPLANE FLIGHT MANUAL (STOWED IN FRONT PASSENGER'S SEAT BACK)	0500832-1	1.2	50.0
25-14-R	GARMIN G1000 COCKPIT REFERENCE GUIDE (STOWED IN COCKPIT SIDE PANEL POCKET)		1.5	15.0
25-15-O	APPROACH PLATE HOLDER	0519107-1	0.1	22.0
25-16-S	FUEL SAMPLING CUP	S2107-1	0.1	14.3
25-17-S	ARTEX ME406 - 2 FREQUENCY ELT (if installed)	3940458-1	2.5*	134.6*
	- ELT TRANSMITTER	ME406	2.0	135.5
	- ANTENNA AND CABLE ASSY	110-338	0.5	130.0
25-18-S	ARTEX ELT1000 - 2 FREQUENCY ELT (if installed)	3940458-1	2.5*	134.6*
	- ELT TRANSMITTER	ELT1000	2.0	135.5
	- ANTENNA AND CABLE ASSY	110-338	0.5	130.0
25-10-O	ARTEX C406-N - 3 FREQUENCY ELT	3040460.1	5.1*	135.0*
	- ELT TRANSMITTER	C406-N	4.6	135.5
	- ANTENNA AND CABLE ASSY	110-338	0.5	130.0

Figure 6-9 (Sheet 2)

TEMPORARY REVISION FOR CESSNA PILOT'S OPERATING HANDBOOK  
AND FAA APPROVED AIRPLANE FLIGHT MANUAL

Publication Affected: Model 172S Nav III (GFC 700), Serials 172S10468, 172S10507, 172S10640 and 172S10656 and On, basic Pilot's Operating Handbook and FAA Approved Airplane Flight Manual, Revision 4, dated 11 June 2021.

Airplane Serial Numbers Affected: Airplanes 172S10468, 172S10507, 172S10640 and 172S10656 and On.

Description of Change: Section 6, Weight and Balance/Equipment List, Comprehensive Equipment List, page 6-20, update the list of 25 - Equipment/Furnishings.

Filing Instructions: This temporary revision replaces 172SPHBUS-04 TR01 in its entirety. Remove 172SPHBUS-04 TR01 from the POH. Insert this temporary revision in the Model 172S Nav III (GFC 700), Serials 172S10468, 172S10507, 172S10640 and 172S10656 and On, Pilot's Operating Handbook and FAA Approved Airplane Flight Manual adjacent to page 6-20.

Removal Instructions: This temporary revision must be removed and discarded when Revision 5 has been collated into the basic Pilot's Operating Handbook and FAA Approved Airplane Flight Manual.

---

In Section 6, Weight and Balance/Equipment List, Comprehensive Equipment List, page 6-20, replace Figure 6-9 (Sheet 2), with the updated list of 25 - Equipment/Furnishings as shown on the opposite page:

  
**APPROVED BY**

Ryan Schober, ODA Deputy Administrator

Textron Aviation Inc.

Organization Designation Authorization ODA-100129-CE

FAA Approved Under 14 CFR Part 183 Subpart D

FAA APPROVED  
172SPHBUS-04 TR05

**TEMPORARY REVISION FOR CESSNA PILOT'S OPERATING HANDBOOK  
AND FAA APPROVED AIRPLANE FLIGHT MANUAL**

<b>ITEM NO</b>	<b>EQUIPMENT LIST DESCRIPTION</b>	<b>REF DRAWING</b>	<b>WT LBS</b>	<b>ARM INS.</b>
<b>25 - EQUIPMENT/FURNISHINGS</b>				
25-01-R	SEAT, PILOT, ADJUSTABLE, LEATHER/VINYL COVER or SEAT, PILOT, ADJUSTABLE, LEATHER/VINYL COVER	0719025-4 0519151-1	33.0 30.0	41.5 41.5
25-02-S	SEAT, FRONT PASSENGER, ADJUSTABLE, LEATHER/VINYL COVER or SEAT, FRONT PASSENGER, ADJUSTABLE, LEATHER/VINYL COVER	0719025-4 0519151-2	33.0 30.0	41.5 41.5
25-03-S	SEAT, REAR PASSENGER, ONE-PIECE BACK, LEATHER/VINYL COVER or SEAT, REAR PASSENGER, ONE-PIECE BACK, LEATHER/VINYL COVER	0519101-1 0519156-1	38.7 30.7	79.5 79.5
25-04-O	SEAT, REAR OBSERVER, ADJUSTABLE, LEATHER/VINYL COVER or SEAT, REAR OBSERVER, ADJUSTABLE, LEATHER/VINYL COVER	0519109-2 0519165-1	27.9 27.9	72.5 72.5
25-07-R	SEAT BELT AND SHOULDER HARNESS, INERTIA REEL, AUTO ADJUST, PILOT AND FRONT PASSENGER	0519031-1	5.2	54.0
25-08-S	SEAT BELT AND SHOULDER HARNESS, INERTIA REEL, AUTO ADJUST, REAR SEAT	0519031-1	5.2	90.0
25-09-S	SUN VISOR (SET OF 2)	0514166-2	1.1	32.8
25-10-S	BAGGAGE RESTRAINT NET	2015009-7	0.5	95.0
25-11-S	CARGO TIEDOWN RINGS (SET OF 6)	0515055-6	0.2	95.0
25-12-S	TOW BAR, NOSE GEAR (STOWED)	0501019-1	1.7	124.0
25-13-R	PILOT'S OPERATING HANDBOOK AND FAA APPROVED AIRPLANE FLIGHT MANUAL (STOWED IN FRONT PASSENGER'S SEAT BACK)	0500832-1	1.2	50.0
25-14-R	GARMIN G1000 COCKPIT REFERENCE GUIDE (STOWED IN COCKPIT SIDE PANEL POCKET)		1.5	15.0
25-15-O	APPROACH PLATE HOLDER or APPROACH PLATE HOLDER	0519107-1 0519161-6	0.1 0.1	22.0 22.0
25-16-S	FUEL SAMPLING CUP	S2107-1	0.1	14.3
25-17-S	ARTEX ME406 - 2 FREQUENCY ELT (if installed) - ELT TRANSMITTER	3940458-1 ME406	2.5* 2.0	134.6* 135.5
	- ANTENNA AND CABLE ASSY	110-338	0.5	130.0
25-18-S	ARTEX ELT1000 - 2 FREQUENCY ELT (if installed) - ELT TRANSMITTER	3940458-1 ELT1000	2.5* 2.0	134.6* 135.5
	- ANTENNA AND CABLE ASSY	110-338	0.5	130.0
25-19-O	ARTEX C406-N - 3 FREQUENCY ELT - ELT TRANSMITTER	3940460-1 C406-N	5.1* 4.6	135.0* 135.5
	- ANTENNA AND CABLE ASSY	110-338	0.5	130.0

Figure 6-9 (Sheet 2)

TEMPORARY REVISION FOR CESSNA PILOT'S OPERATING HANDBOOK  
AND FAA APPROVED AIRPLANE FLIGHT MANUAL

Publication Affected: Model 172S Nav III (GFC 700), Serials 172S10468, 172S10507, 172S10640 and 172S10656 and On, basic Pilot's Operating Handbook and FAA Approved Airplane Flight Manual, Revision 4, dated 11 June 2021.

Airplane Serial Numbers Affected: Airplanes 172S10468, 172S10507, 172S10640 and 172S10656 and On.

Description of Change: Section 6, Weight and Balance/Equipment List, Comprehensive Equipment List, page 6-20, update the list of 25 - Equipment/Furnishings.

Filing Instructions: Insert this temporary revision in the Model 172S Nav III (GFC 700), Serials 172S10468, 172S10507, 172S10640 and 172S10656 and On, Pilot's Operating Handbook and FAA Approved Airplane Flight Manual adjacent to page 6-20.

Removal Instructions: This temporary revision must be removed and discarded when Revision 5 has been collated into the basic Pilot's Operating Handbook and FAA Approved Airplane Flight Manual.

---

In Section 6, Weight and Balance/Equipment List, Comprehensive Equipment List, page 6-20, replace figure 6-9 (Sheet 2), with the updated list of 25 - Equipment/Furnishings as shown on the opposite page:

APPROVED BY *Mark Fuller*

for

Stephen Gielsch, Lead ODA Administrator  
Textron Aviation Inc.  
Organization Delegation Authorization ODA-100129-CE  
FAA Approved Under 14 CFR Part 183 Subpart D

DATE OF APPROVAL *28 Oct. 2021*

FAA APPROVED  
172SPHBUS-04 TR01

TEMPORARY REVISION FOR CESSNA PILOT'S OPERATING HANDBOOK  
AND FAA APPROVED AIRPLANE FLIGHT MANUAL

ITEM NO	EQUIPMENT LIST DESCRIPTION	REF DRAWING	WT LBS	ARM INS.
<b>25 - EQUIPMENT/FURNISHINGS</b>				
25-01-R	SEAT, PILOT, ADJUSTABLE, LEATHER/VINYL COVER	0719025-4	33.0	41.5
25-02-S	SEAT, FRONT PASSENGER, ADJUSTABLE, LEATHER/VINYL COVER	0719025-4	33.0	41.5
25-03-S	SEAT, REAR PASSENGER, ONE-PIECE BACK, LEATHER/VINYL COVER	0519101-1	38.7	79.5
25-04-O	SEAT, REAR OBSERVER, ADJUSTABLE, LEATHER/VINYL COVER	0519109-2	27.9	72.5
25-07-R	SEAT BELT AND SHOULDER HARNESS, INERTIA REEL, AUTO ADJUST, PILOT AND FRONT PASSENGER	0519031-1	5.2	54.0
25-08-S	SEAT BELT AND SHOULDER HARNESS, INERTIA REEL, AUTO ADJUST, REAR SEAT	0519031-1	5.2	90.0
25-09-S	SUN VISOR (SET OF 2)	0514166-2	1.1	32.8
25-10-S	BAGGAGE RESTRAINT NET	2015009-7	0.5	95.0
25-11-S	CARGO TIEDOWN RINGS (SET OF 6)	0515055-6	0.2	95.0
25-12-S	TOW BAR, NOSE GEAR (STOWED)	0501019-1	1.7	124.0
25-13-R	PILOT'S OPERATING HANDBOOK AND FAA APPROVED AIRPLANE FLIGHT MANUAL (STOWED IN FRONT PASSENGER'S SEAT BACK)	0500832-1	1.2	50.0
25-14-R	GARMIN G1000 COCKPIT REFERENCE GUIDE (STOWED IN COCKPIT SIDE PANEL POCKET)		1.5	15.0
25-15-O	APPROACH PLATE HOLDER	0519107-1	0.1	22.0
25-16-S	FUEL SAMPLING CUP	S2107-1	0.1	14.3
25-17-S	ARTEX ME406 - 2 FREQUENCY ELT (if installed)	3940458-1	2.5*	134.6*
	- ELT TRANSMITTER	ME406	2.0	135.5
	- ANTENNA AND CABLE ASSY	110-338	0.5	130.0
25-18-S	ARTEX ELT1000 - 2 FREQUENCY ELT (if installed)	3940458-1	2.5*	134.6*
	- ELT TRANSMITTER	ELT1000	2.0	135.5
	- ANTENNA AND CABLE ASSY	110-338	0.5	130.0
25-19-O	ARTEX C406-N - 3 FREQUENCY ELT	3940460-1	5.1*	135.0*
	- ELT TRANSMITTER	C406-N	4.6	135.5
	- ANTENNA AND CABLE ASSY	110-338	0.5	130.0

Figure 6-9 (Sheet 2)

ITEM NO	EQUIPMENT LIST DESCRIPTION	REF DRAWING	WT LBS	ARM INS.
<b>26 - FIRE PROTECTION</b>				
26-01-S	FIRE EXTINGUISHER	0501011-2	5.3*	43.0*
	- FIRE EXTINGUISHER, HAND TYPE	A352GS	4.8	44.0
	- MOUNTING CLAMP AND HARDWARE	1290010-1	0.5	42.2
<b>27 - FLIGHT CONTROLS</b>				
27-01-S	DUAL CONTROLS, RIGHT SEAT	0506008-1	5.5*	12.4*
	- CONTROL WHEEL, COPILOT	0513576-4	2.6	26.0
	- RUDDER AND BRAKE PEDAL, COPILOT	0510402-16	1.1	6.8
27-02-A	RUDDER PEDAL EXTENSION (SET OF 2) (INSTALLED ARM SHOWN)	0501082-1	2.0	8.0
<b>28 - FUEL</b>				
28-01-R	AUXILIARY FUEL PUMP - 5100-00-4	0516015	1.9	9.5
28-02-R	FUEL SENDER - 76-207-3	0522644	0.9	47.4
<b>30 - ICE AND RAIN PROTECTION</b>				
30-01-S	PITOT HEAT	0523080	0.1	28.0
<b>31 - INDICATING/RECORDING SYSTEM</b>				
31-01-S	RECORDING HOURMETER - C664503-0103	0506009	0.5	16.1
31-02-R	PNEUMATIC STALL WARNING SYSTEM	0523112	0.4	28.5
31-03-R	GEA 71 ENGINE/AIRFRAME UNIT	3930377	2.2	11.4
31-04-R	GTP 59 OUTSIDE AIR TEMPERATURE (OAT) PROBE	0518006	0.1	41.5
<b>32 - LANDING GEAR</b>				
32-01-R	WHEEL BRAKE AND TIRE, 6.00 X 6 MAIN (2)	0541200-7, -8	34.4*	57.8*
	- WHEEL ASSY (EACH)	C163001-0104	6.2	58.2
	- BRAKE ASSY (EACH)	C163030-0111	1.8	54.5
	- TIRE, 6-PLY, 6.00 X 6, BLACKWALL (EACH)	C262003-0101	7.9	58.2
	- TUBE, (EACH)	C262023-0102	1.3	58.2
32-02-R	WHEEL AND TIRE ASSY, 5.00 X 5 NOSE	0543062-17	9.5*	-6.8*
	- WHEEL ASSY	1241156-12	3.5	-6.8
	- TIRE, 6-PLY, 5.00 X 5, BLACKWALL	C262003-0202	4.6	-6.8
32-03-S	WHEEL FAIRING AND INSTALLATION	C262023-0101	1.4	-6.8
	- WHEEL FAIRING, NOSE	0541225-1	16.5*	46.1*
	- WHEEL FAIRINGS, MAIN (SET OF 2)	0543079-3	3.5	-3.5
	- BRAKE FAIRINGS (SET OF 2)	0541223-1, -2	10.1	61.1
	- MOUNTING PLATE (SET OF 2)	0541224-1, -2	1.1	55.6
		0541220-1, -2	0.8	59.5

Figure 6-9 (Sheet 3)

SECTION 6  
WEIGHT AND BALANCE/  
EQUIPMENT LIST

CESSNA  
MODEL 172S NAV III  
GFC 700 AFCS

ITEM NO	EQUIPMENT LIST DESCRIPTION	REF DRAWING	WT LBS	ARM INS.
<b>33 - LIGHTS</b>				
33-01-S	MAP LIGHT IN CONTROL WHEEL	0706015	0.2	22.0
33-02-S	COURTESY LIGHTS UNDER WING	0521101-8	0.5	61.0
33-03-S	FLASHING BEACON	0506003-6	1.4	240.7
33-04-R	STROBE LIGHT	0723628	3.4	43.3
33-05-S	LANDING AND TAXI LIGHT, HID (LAMP AND BALLAST)	0523029-7	3.1	26.6
33-06-S	LANDING, TAXI AND RECOGNITION LIGHTS, LED	0728004-1,-2	2.8	26.6
<b>34 - NAVIGATION</b>				
34-01-R	STANDBY AIRSPEED INDICATOR - S3325-6 (if installed)	0506009	0.7	16.2
34-02-R	STANDBY ATTITUDE INDICATOR - S3326-2 (if installed)	0501135	2.2	14.0
34-03-R	STANDBY ALTIMETER, SENSITIVE WITH 20 FOOT MARKINGS, INCHES OF MERCURY AND MILLBARS - S3827-1 (if installed)	0506009	0.9	14.0
34-04-R	STANDBY FLIGHT INSTRUMENT (if installed)	3930499-2		
	- GI 275 STANDBY FLIGHT INSTRUMENT	3910317-34	2.4	13.5
34-05-S	ALTERNATE STATIC AIR SOURCE	0501017-1	0.2	15.5
34-06-R	COMPASS, MAGNETIC	0513262-3	0.5	18.0
34-07-R	TRANSPONDER	3940397	3.1*	114.0*
	- GTX-33 TRANSPONDER	3910317	3.6	134.0
	- CI 105-16 TRANSPONDER ANTENNA	3960191	0.4	86.3
34-08-R	PFD DISPLAY	3930377		
	- GDU DISPLAY	3910317	6.4	16.26
34-09-R	MFD DISPLAY	3930377		
	- GDU DISPLAY	3910317	6.4	16.26
34-10-R	ATTITUDE HEADING REFERENCE SENSOR (AHRS)	3940397	2.5*	118.75*
	- GRS 77 AHRS	3910317	2.4	134.0
	- GMU 44 MAGNETOMETER	3940398	0.3	52.7
34-11-R	AIR DATA COMPUTER	3940397	1.7*	118.69*
	- GDC 74A AIR DATA COMPUTER	3910317		
34-12-O	GDL-69A DATALINK	3940397	4.0	47.0
34-13-O	AUTOMATIC DIRECTION FINDER (ADF)		8.2*	26.9*
	- KR 87 ADF RECEIVER	3930494	3.2	12.1
	- ADF ANTENNA	3960187	4.2	39.3
34-14-O	DISTANCE MEASURING EQUIPMENT (DME)		3.2*	146.9*
	- KN 63 REMOTE DME	3940448	2.8	154.0
	- CI 105-16 DME ANTENNA	3960231	0.4	114.5

Figure 6-9 (Sheet 4)

ITEM NO	EQUIPMENT LIST DESCRIPTION	REF DRAWING	WT LBS	ARM INS.
<b>37 - VACUUM (if installed)</b>				
37-01-R	ENGINE DRIVEN VACUUM PUMP			
	- VACUUM PUMP - AA3215CC	0501135	2.1	-5.0
	- COOLING SHROUD	1201998-1	0.2	-5.6
	- FILTER	1201075-2	0.3	2.0
	- VACUUM REGULATOR	AA2H3-2	0.5	2.0
37-02-R	VACUUM TRANSDUCER - P165-5786	0501135	0.3	10.3
<b>53 - FUSELAGE</b>				
53-01-S	REFUELING STEPS AND HANDLE	0513415-2	1.7	16.3
<b>56 - WINDOWS</b>				
56-01-S	WINDOW, HINGED RIGHT SIDE (NET CHANGE)	0517001-40	2.3*	48.5
56-02-S	WINDOW, HINGED LEFT SIDE (NET CHANGE)	0517001-39	2.3*	48.5
<b>61 - PROPELLER</b>				
61-01-R	FIXED PITCH PROPELLER ASSEMBLY	0550320-18	38.8*	-38.2*
	- MCCAULEY 76 INCH PROPELLER	IA170EJHA7660	35.0	-38.4
	- MCCAULEY 3.5 INCH PROPELLER SPACER	C5464	3.6	-36.0
61-02-R	SPINNER INSTALLATION, PROPELLER	0550320-11	1.8*	-41.0*
	- SPINNER DOME ASSEMBLY	0550236-14	1.0	-42.6
	- FWD SPINNER BULKHEAD	0552231-1	0.3	-40.8
	- AFT SPINNER BULKHEAD	0550321-10	0.4	-37.3
<b>71 - POWERPLANT</b>				
71-01-R	FILTER, INDUCTION AIR	0550365	0.6	-27.5
71-02-O	WINTERIZATION KIT INSTALLATION (STOWED) (INSTALLED ARM SHOWN)	0501128-3	0.8*	-20.3*
	- BREATHER TUBE INSULATION	0552011	0.4	-13.8
	- COWL INLET COVERS (INSTALLED)	0552229-3, -4	0.3	-32.0
	- COWL INLET COVERS (STOWED)	0552229-3, -4	0.3	95.0
<b>72 - ENGINES</b>				
72-01-R	ENGINE, LYCOMING IO-360-L2A	0550365	297.8*	-18.6*

Figure 6-9 (Sheet 5)

SECTION 6  
WEIGHT AND BALANCE/  
EQUIPMENT LIST

CESSNA  
MODEL 172S NAV III  
GFC 700 AFCS

ITEM NO	EQUIPMENT LIST DESCRIPTION	REF DRAWING	WT LBS	ARM INS.
<b>73 - ENGINE FUEL AND CONTROL</b>				
73-01-R	FUEL FLOW TRANSDUCER - 680501K	0501168	0.8	-22.6
<b>77 - ENGINE INDICATING</b>				
77-01-R	ENGINE TACHOMETER SENSOR - 1A3C-2	0501168	0.2	-8.0
77-02-S	CYLINDER HEAD THERMOCOUPLES (ALL CYLINDERS) - 32DKWUE006F0126	0501168	0.2	-12.0
77-03-S	EXHAUST THERMOCOUPLES (ALL CYLINDERS) - 86317	0501168	0.3	-12.0
<b>78 - EXHAUST</b>				
78-01-R	EXHAUST SYSTEM	9954100-1	16.3*	-20.0*
	- MUFFLER AND TAILPIPE WELD ASSEMBLY	9954100-2	4.6	-22.7
	- SHROUD ASSEMBLY, MUFFLER HEATER	9954100-3	0.8	-22.7
<b>79 - OIL</b>				
79-01-R	OIL COOLER - 10877A	0550365	3.3	-11.0
79-02-R	OIL PRESSURE SENSOR - P165-5281	0550365	0.2	-12.9
79-03-R	OIL TEMPERATURE SENSOR - S2335-1	0550365	0.2	-8.5

Figure 6-9 (Sheet 6)

## AIRPLANE AND SYSTEMS DESCRIPTION

### TABLE OF CONTENTS

	Page
Introduction . . . . .	7-5
Airframe . . . . .	7-5
Flight Controls . . . . .	7-7
Trim Systems . . . . .	7-7
Instrument Panel . . . . .	7-10
Pilot Panel Layout . . . . .	7-10
Center Panel Layout . . . . .	7-11
Right Panel Layout . . . . .	7-13
Center Pedestal Layout . . . . .	7-13
Flight Instruments . . . . .	7-18
Attitude Indicator . . . . .	7-18
Airspeed Indicator . . . . .	7-19
Altimeter . . . . .	7-19
Standby Flight Instrument (if installed) . . . . .	7-20
Horizontal Situation Indicator . . . . .	7-20
Vertical Speed Indicator . . . . .	7-22
Ground Control . . . . .	7-22
Wing Flap System . . . . .	7-23
Landing Gear System . . . . .	7-23
Baggage Compartment . . . . .	7-24
Seats . . . . .	7-24
Integrated Seat Belt/Shoulder Harness . . . . .	7-25
Entrance Doors And Cabin Windows . . . . .	7-27
Control Locks . . . . .	7-28
Engine . . . . .	7-29
Engine Controls . . . . .	7-29
Engine Instruments . . . . .	7-30
RPM (Tachometer) . . . . .	7-31
Fuel Flow . . . . .	7-32
Oil Pressure . . . . .	7-32
Oil Temperature . . . . .	7-33

(Continued Next Page)

**TABLE OF CONTENTS** (Continued)

	Page
Cylinder Head Temperature . . . . .	7-34
Exhaust Gas Temperature . . . . .	7-34
New Engine Break-In And Operation . . . . .	7-35
Engine Lubrication System . . . . .	7-35
Ignition And Starter System . . . . .	7-36
Air Induction System . . . . .	7-36
Exhaust System . . . . .	7-37
Fuel Injection System . . . . .	7-37
Cooling System . . . . .	7-37
Propeller . . . . .	7-37
Fuel System . . . . .	7-38
Fuel Distribution . . . . .	7-39
Fuel Indicating System . . . . .	7-39
Fuel Calculations . . . . .	7-41
Auxiliary Fuel Pump Operation . . . . .	7-43
Fuel Return System . . . . .	7-44
Fuel Venting . . . . .	7-44
Reduced Tank Capacity . . . . .	7-44
Fuel Selector Valve . . . . .	7-45
Fuel Drain Valves . . . . .	7-46
Brake System . . . . .	7-46
Electrical System . . . . .	7-47
G1000 Annunciator Panel . . . . .	7-51
Master Switch . . . . .	7-51
Standby Battery Switch . . . . .	7-52
Avionics Switch . . . . .	7-52
Electrical System Monitoring And Annunciations . . . . .	7-53
Bus Voltage (Volts) . . . . .	7-53
Ammeters . . . . .	7-54
Standby Battery Annunciation . . . . .	7-54
Low Voltage Annunciation . . . . .	7-55
High Voltage Annunciation . . . . .	7-56
Circuit Breakers And Fuses . . . . .	7-57
External Power Receptacle . . . . .	7-58

(Continued Next Page)

## TABLE OF CONTENTS (Continued)

	Page
Lighting Systems .....	7-59
Exterior Lighting .....	7-59
Interior Lighting .....	7-60
Cabin Heating, Ventilating And Defrosting System .....	7-62
Pitot-Static System And Instruments .....	7-64
■ Vacuum System And Instruments (if installed) .....	7-65
Attitude Indicator .....	7-65
Vacuum Indicator .....	7-65
Low Vacuum Annunciation .....	7-65
Clock/O.A.T. Indicator .....	7-67
Stall Warning System .....	7-67
Standard Avionics .....	7-68
Garmin Display Units (GDU) .....	7-68
Audio Panel (GMA) .....	7-69
Integrated Avionics Unit (GIA) .....	7-69
Attitude and Heading Reference System (AHRS) and Magnetometer (GRS) .....	7-69
Air Data Computer (GDC) .....	7-70
Engine Monitor (GEA) .....	7-70
Transponder (GTX) .....	7-70
■ XM Weather and Radio Data Link (GDL) .....	7-70
GFC 700 Automatic Flight Control System (AFCS) (if installed) ..	7-71
Control Wheel Steering (CWS) .....	7-71
Avionics Support Equipment .....	7-73
Avionics Cooling Fans .....	7-73
Antennas .....	7-74
Microphone And Headset Installations .....	7-75
Auxiliary Audio Input Jack .....	7-76
12V Power Outlet (if installed) .....	7-77
Static Dischargers .....	7-78
Cabin Features .....	7-79
Emergency Locator Transmitter (ELT) .....	7-79
Cabin Fire Extinguisher .....	7-79
Carbon Monoxide Detection System .....	7-80



## INTRODUCTION

This section provides description and operation of the airplane and its systems. Some equipment described herein is optional and may not be installed in the airplane. Refer to Section 9, Supplements, for details of other optional systems and equipment.

## AIRFRAME

The airplane is an all metal, four-place, high wing, single-engine airplane equipped with tricycle landing gear and is designed for general utility and training purposes.

The construction of the fuselage is a conventional formed sheet metal bulkhead, stringer, and skin design referred to as semimonocoque. Major items of structure are the front and rear carry through spars to which the wings are attached, a bulkhead and forgings for main landing gear attachment at the base of the rear door posts, and a bulkhead with attach fittings at the base of the forward door posts for the lower attachment of the wing struts. Four engine mount stringers are also attached to the forward door posts and extend forward to the firewall.

The externally braced wings, containing integral fuel tanks, are constructed of a front and rear spar with formed sheet metal ribs, doublers, and stringers. The entire structure is covered with aluminum skin. The front spars are equipped with wing-to-fuselage and wing-to-strut attach fittings. The aft spars are equipped with wing-to-fuselage attach fittings, and are partial span spars. Conventional hinged ailerons and single slot type flaps are attached to the trailing edge of the wings. The ailerons are constructed of a forward spar containing balance weights, formed sheet metal ribs and V type corrugated aluminum skin joined together at the trailing edge. The flaps are constructed basically the same as the ailerons, with the exception of the balance weights and the addition of a formed sheet metal leading edge section.

The empennage (tail assembly) consists of a conventional vertical stabilizer, rudder, horizontal stabilizer, and elevator. The vertical stabilizer consists of a spar, formed sheet metal ribs and reinforcements, a wraparound skin panel, formed leading edge skins and a dorsal.

(Continued Next Page)

## **AIRFRAME** (Continued)

The rudder is constructed of a formed leading edge skin and spar with attached hinge brackets and ribs, a center spar, a wrap around skin, and a ground adjustable trim tab at the base of the trailing edge. The top of the rudder incorporates a leading edge extension which contains a balance weight.

The horizontal stabilizer is constructed of a forward and aft spar, ribs and stiffeners, center, left, and right wrap around skin panels, and formed leading edge skins. The horizontal stabilizer also contains the elevator trim tab actuator.

Construction of the elevator consists of formed leading edge skins, a forward spar, aft channel, ribs, torque tube and bellcrank, left upper and lower "V" type corrugated skins, and right upper and lower "V" type corrugated skins incorporating a trailing edge cutout for the trim tab. The elevator tip leading edge extensions incorporate balance weights. The elevator trim tab consists of a spar, rib, and upper and lower "V" type corrugated skins.

## **FLIGHT CONTROLS**

The airplane's flight control system, refer to Figure 7-1, consists of conventional aileron, rudder, and elevator control surfaces. The control surfaces are manually operated through cables and mechanical linkage using a control wheel for the ailerons and elevator, and rudder/brake pedals for the rudder.

## **TRIM SYSTEMS**

A manually operated elevator trim system is provided on this airplane, refer to Figure 7-1. Elevator trimming is accomplished through the elevator trim tab by utilizing the vertically mounted trim control wheel on the center pedestal. Forward rotation of the trim wheel will trim nose down, conversely, aft rotation will trim nose up.

(Continued Next Page)

## FLIGHT CONTROLS AND TRIM SYSTEM

B3106

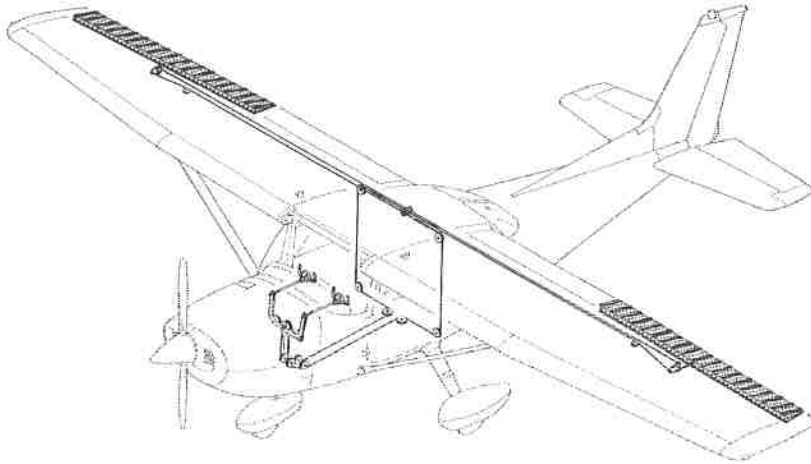

Aileron Control System

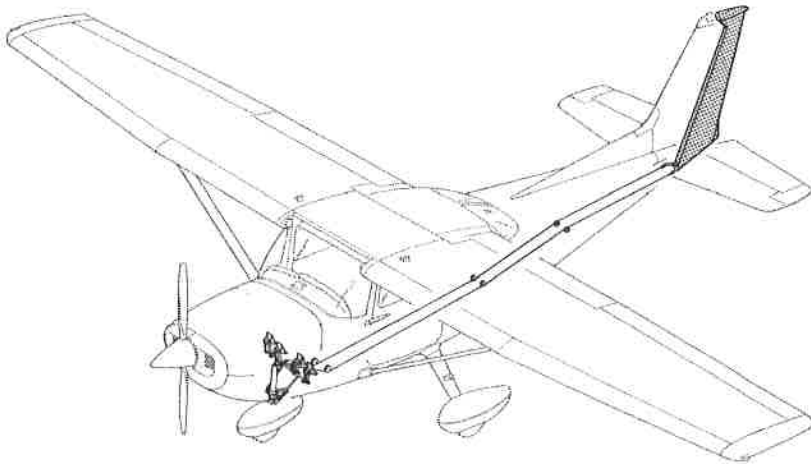

Rudder Control System

0585R1017

Figure 7-1\* (Sheet 1 of 2)

## FLIGHT CONTROLS AND TRIM SYSTEMS

B3107

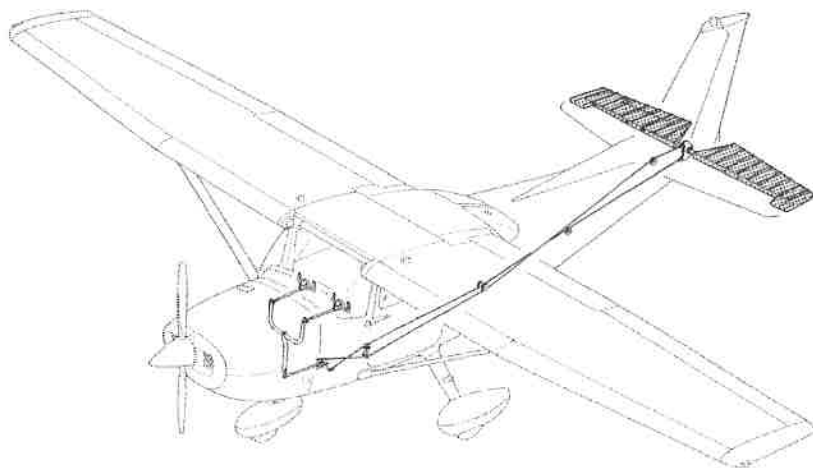

Elevator Control System

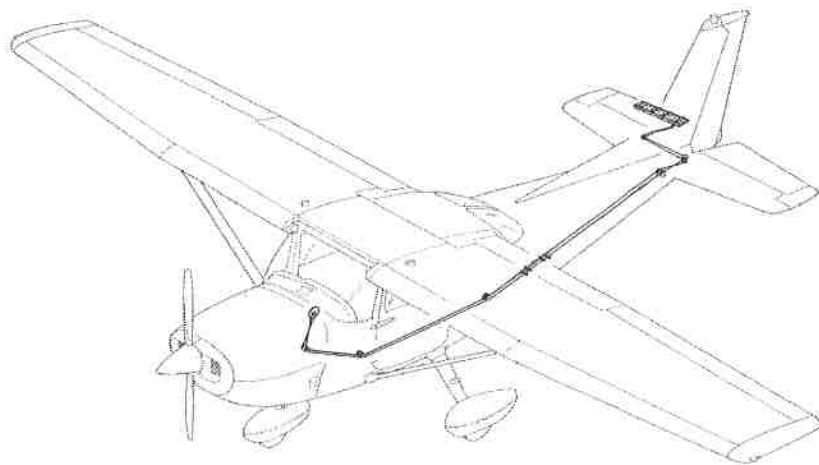

Elevator Trim Control System

0585R1017

Figure 7-1\* (Sheet 2)

## **INSTRUMENT PANEL**

The instrument panel, refer to Figure 7-2, is of all metal construction and is installed in sections so equipment can be easily removed for maintenance. The glareshield, above and projecting aft from the instrument panel, limits undesirable reflections on the windshield from lighted equipment and displays mounted in the instrument panel.

The Nav III instrument panel contains the Garmin Display Unit (GDU) Primary Flight Display (PFD) and Multifunction Display (MFD) and the Garmin Audio Panel. For specific details regarding the instruments, switches, circuit breakers and controls on the instrument panel, refer to the related topics in this section.

## **PILOT PANEL LAYOUT**

The PFD, centered on the instrument panel in front of the pilot, shows the primary flight instruments during normal operation. During engine start, reversionary operation (MFD failure), or when the DISPLAY BACKUP switch is selected, the Engine Indication System (EIS) is shown on the PFD. Refer to the Garmin G1000 Cockpit Reference Guide (CRG) for specific operating information.

The Standby Battery (STBY BATT) switch is found at the upper left corner of the pilot instrument panel on an internally lighted subpanel. The switch positions (ARM/OFF/TEST) select the standby battery operating modes. The rocker-type MASTER and AVIONICS switches are found immediately below the standby battery switch.

The controls for adjusting instrument panel, equipment, and pedestal lighting are found together on the subpanel below the MASTER and AVIONICS switches. See the INTERNAL LIGHTING paragraphs of this section for more information.

(Continued Next Page)

## **INSTRUMENT PANEL** (Continued)

### **PILOT PANEL LAYOUT** (Continued)

Switches for the airplane electrical systems and equipment are found on an internally lighted subpanel found below the lower left corner of the PFD. Each switch is labeled for function and is ON when the handle is in the up position. See the ELECTRICAL EQUIPMENT descriptions in this section for further information.

The circuit breaker panel is found along the lower edge of the pilot's instrument panel below the electrical equipment switch panel and pilot control wheel column. Each circuit breaker is identified for the equipment or function it controls and for the bus from which it receives power. Lighting for this subpanel is controlled using the SW/CB PANELS dimmer control. See the ELECTRICAL EQUIPMENT descriptions in this section for further information.

### **CENTER PANEL LAYOUT**

The Garmin audio panel is found on the upper half of the center instrument panel, immediately to the right of the PFD. A pushbutton switch labeled DISPLAY BACKUP, to manually select display reversion mode, is found on the lower face of the audio panel. Refer to the Garmin G1000 CRG for operating information.

The MFD is found on the upper center panel to the right of the audio panel. The MFD depicts EIS information along the left side of the display and shows navigation, terrain, lightning and traffic data on the moving map. Flight management or display configuration information can be shown on the MFD in place of the moving map pages. Refer to the Garmin G1000 CRG for operating information.

(Continued Next Page)

## **INSTRUMENT PANEL** (Continued)

### **CENTER PANEL LAYOUT** (Continued)

The standby instrument cluster (if installed) is in the center instrument panel below the audio panel. A conventional (mechanical) airspeed indicator and a sensitive aneroid altimeter are on each side of the vacuum-powered attitude indicator. The pitot-static instruments share the airplane pitot head and static ports with the air data computer. The attitude indicator features a low vacuum flag to provide immediate warning of vacuum system failure.

The Standby Flight Instrument (GI 275) (if installed) is in the center instrument panel below the MFD, refer to Figure 7-2. The instrument provides airplane attitude, airspeed, altitude, vertical speed and slip/skid indications for use during PFD and MFD failure. Refer to FLIGHT INSTRUMENTS description in this section for operational information on the Standby Flight Instrument.

The engine controls are found on the lower center instrument panel below the standby instrument cluster. The controls are conventional push-pull-type controls for throttle and mixture. See ENGINE description in this section for operating information.

The alternate static air valve is found adjacent to the throttle control. Refer to the PITOT-STATIC SYSTEM AND INSTRUMENTS description in this section for operating information.

The wing flap control lever and indicator are found at the lower right side of the center panel. Refer to the WING FLAP SYSTEM description in this section for operating information.

(Continued Next Page)

## **INSTRUMENT PANEL** (Continued)

### **RIGHT PANEL LAYOUT**

The Emergency Locator Transmitter (ELT) remote switch (ON/ARM/TEST RESET) is positioned at the upper inboard corner of the right panel adjacent to the MFD. Refer to Section 9, Supplements 1 or 2 for appropriate ELT operating information.

The Hour (Hobbs) meter is found to the right of the ELT switch and records engine operating time, when oil pressure is greater than 20 PSI, for maintenance purposes. Refer to the ENGINE INSTRUMENTS description in this section for further information.

### **CENTER PEDESTAL LAYOUT**

The center pedestal, located below the center panel, contains the elevator trim control wheel, trim position indicator, 12V power outlet (if installed), aux audio input jack, fuel shutoff valve, and the hand-held microphone. The fuel selector valve handle is located at the base of the pedestal.

### INSTRUMENT PANEL

(SERIALS 172S10468, 172S10507, 172S10640, AND 172S10656  
THRU 172S12700)

B9020

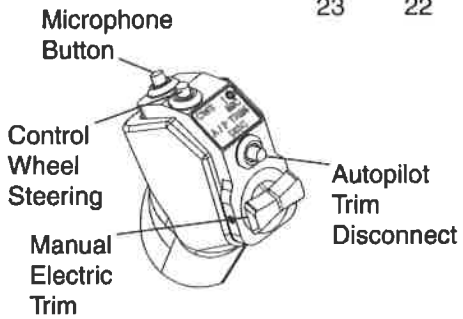
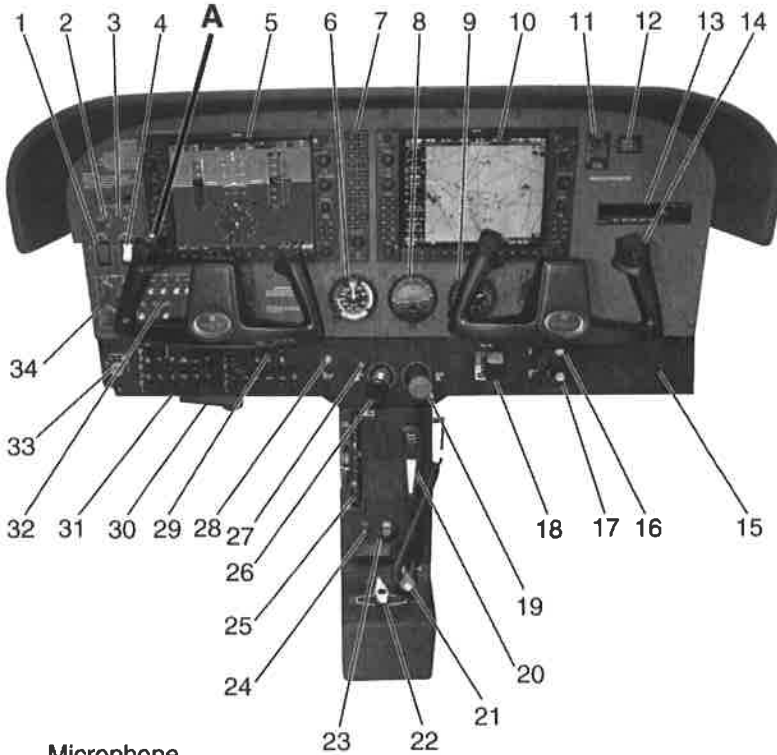

**DETAIL A**

0519P1114

Figure 7-2 (Sheet 1 of 2)

## INSTRUMENT PANEL

**(SERIALS 172S10468, 172S10507, 172S10640, AND 172S10656  
THRU 172S12700)**

1. MASTER Switch (ALT and BAT)
2. STBY BATT Switch
3. STBY BATT Test Annunciator
4. AVIONICS Switch (BUS 1 and BUS 2)
5. Primary Flight Display
6. Standby Airspeed Indicator
7. Audio Control Panel
8. Standby Attitude Indicator
9. Standby Altimeter
10. Multifunction Display
11. ELT Remote Switch/Annunciator
12. Flight Hour Recorder
13. Bendix/King KR87 Automatic Direction Finder (if installed)
14. Microphone Button
15. Glove Box
16. Cabin Heat Control
17. Cabin Air Control
18. Wing Flap Control Lever And Position Indicator
19. Mixture Control Knob
20. Handheld Microphone
21. Fuel Shutoff Valve
22. Fuel Selector Valve
23. 12V/10A Power Outlet (if installed)
24. Aux Audio Input Jack
25. Elevator Trim Control Wheel And Position Indicator
26. Throttle Control Knob (With Friction Lock)
27. Go-Around Button
28. ALT Static Air Valve Control
29. Yoke Mounted Map Light
30. Parking Brake Handle
31. Circuit Breaker Panel
32. Electrical Switch Panel
33. MAGNETOS/START Switch
34. DIMMING Panel

# INSTRUMENT PANEL (SERIALS 172S12701 AND ON)

B22076

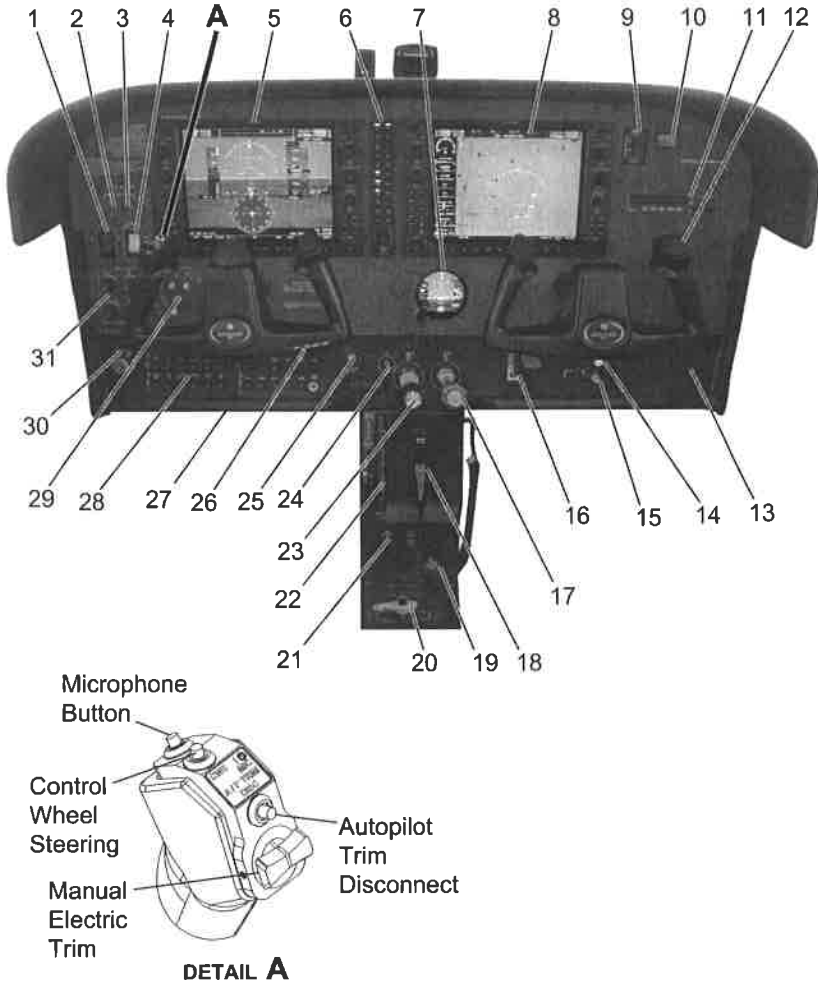

Figure 7-2 (Sheet 2)\*

0519P1114

## **INSTRUMENT PANEL (SERIALS 172S12701 AND ON)**

1. MASTER Switch (ALT and BAT)
2. STBY BATT Switch
3. STBY BATT Test Annunciator
4. AVIONICS Switch (BUS 1 and BUS 2)
5. Primary Flight Display
6. Audio Control Panel
7. Standby Flight Instrument
8. Multifunction Display
9. ELT Remote Switch/Annunciator
10. Flight Hour Recorder
11. Bendix/King KR87 Automatic Direction Finder (if installed)
12. Microphone Button
13. Glove Box
14. Cabin Heat Control
15. Cabin Air Control
16. Wing Flap Control Lever And Position Indicator
17. Mixture Control Knob
18. Handheld Microphone
19. Fuel Shutoff Valve
20. Fuel Selector Valve
21. Aux Audio Input Jack
22. Elevator Trim Control Wheel And Position Indicator
23. Throttle Control Knob (With Friction Lock)
24. Go-Around Button
25. ALT Static Air Valve Control
26. Yoke Mounted Map Light
27. Parking Brake Handle
28. Circuit Breaker Panel
29. Electrical Switch Panel
30. MAGNETOS/START Switch
31. DIMMING Panel

## FLIGHT INSTRUMENTS

The G1000 Integrated Cockpit System primary flight instrument indications are shown on the PFD. The primary flight instruments are arranged on the PFD in the basic T configuration. The Attitude Indicator (AI) and Horizontal Situation Indicator (HSI) are centered vertically on the PFD and are conventional in appearance and operation. Vertical tape-style (scrolling scale) indicators with fixed pointers and digital displays, show airspeed, altitude, and vertical speed. The vertical indicators take the place of analog indicators with a fixed circular scale and rotating pointer.

Knobs, knob sets (two knobs on a common shaft) and membrane type push button switches, found on the bezel surrounding each GDU display, control COM, NAV, XPDR, AUTOPILOT (if installed) and GPS avionics, set BARO (barometric pressure), CRS (course), and HDG (heading), and work various flight management functions. Some push button switches are dedicated to certain functions (keys) while other switches have functions defined by software (softkeys). A softkey may perform various operations or functions at various times based on software definition. Softkeys are found along the lower bezel of the GDU displays.

### ATTITUDE INDICATOR

The G1000 attitude indicator is shown on the upper center of the PFD. The attitude indication data is provided by the Attitude and Heading Reference System (AHRS). The G1000 attitude indicator provides a horizon line that is the full width of the GDU display.

The roll index scale is conventional with 10° graduations to 30° and then 15° graduations to 60° of roll. The roll pointer is slaved to the airplane symbol. The pitch index scale is graduated in 5° increments with every 10° of pitch labeled. If pitch limits are exceeded in either the nose-up or nose-down direction, red warning chevrons will appear on the indicator to point the way back to level flight. A small white trapezoid located below the roll pointer moves laterally left and right to provide the slip-skid information previously supplied by the skid indicator ball. The trapezoid should be centered below the roll pointer for coordinated turns. The standby (vacuum) attitude indicator (if installed) is found on the lower center instrument panel.

(Continued Next Page)

## **FLIGHT INSTRUMENTS** (Continued)

### **AIRSPPEED INDICATOR**

The G1000 vertical tape airspeed indicator is shown along the upper left side of the PFD. The airspeed indication data is provided by the air data computer unit. Colored bands are provided to indicate the maximum speed, high cruise speed caution range, normal operating range, full wing flap operating range and low airspeed awareness band. Calculated true airspeed is displayed in a window at the bottom edge of the airspeed tape.

- The standby (pneumatic) airspeed indicator (if installed) is found on the lower center instrument panel. Colored arcs are provided to indicate the maximum speed, high cruise speed caution range, normal operating range, full wing flap operating range and low airspeed awareness band.

### **ALTIMETER**

The primary altitude indicator (altimeter) is found along the right side of the attitude indicator on the PFD. The altitude indication data is provided by the air data computer unit. The local barometric pressure is set using the **BARO** knob on the GDU displays.

A cyan selectable altitude reference pointer, bug, is displayed on the altimeter tape and is set using the **ALT SEL** knob on the GDU displays. The altitude bug set-point is shown in a window at the top edge of the altimeter.

- The standby (aneroid) sensitive altimeter (if installed) is found on the lower center instrument panel.

(Continued Next Page)

## **FLIGHT INSTRUMENTS** (Continued)

### **STANDBY FLIGHT INSTRUMENT** (if installed)

The Standby Flight Instrument (GI 275) is a panel mounted electronic situational awareness instrument that provides airplane attitude, airspeed, altitude, vertical speed, slip/skid indications, V speeds and trend vectors for airspeed, altitude and vertical speed. It has internal air data and attitude sensors and shares the airplane pitot head and static ports with the air data computer. When the GI 275 is receiving no Heading data from the Garmin G1000 Avionics System, the heading field on the GI 275 will display a red X in the heading field. The instrument has a rechargeable internal Li-Ion battery pack rated for a minimum run time of 60 minutes. The unit includes internal battery state monitoring and advisory if the required run time cannot be expected at startup. Refer to the Garmin G1000 CRG for more information pertaining to specific system operation of the Standby Flight Instrument for the items listed in this paragraph. Additional system operation information contained in the CRG pertains to the Standby Flight Instrument installed and interfaced with the Garmin G1000 NXi system (if installed) (refer to the Garmin G1000 NXi Integrated Avionics System and GFC 700 AFCS for Textron Aviation Inc. Nav III Series Aircraft Supplement, in Section 9 of this manual).

### **HORIZONTAL SITUATION INDICATOR**

The Horizontal Situation Indicator (HSI) is found along the lower center area of the PFD. The heading indication data is provided by the AHRS and magnetometer units. The HSI combines a stabilized magnetic direction indicator (compass card) with selectable navigation deviation indicators for GPS or VHF navigation. The HSI is conventional in appearance and operation.

Magnetic heading is shown numerically in a window centered above the heading index (lubber line) at the top of the HSI. Reference index marks are provided at 45° intervals around the compass card. A circular segment scale below the heading window at the top of the HSI shows half and standard rates of turn based on the length of the magenta turn vector.

(Continued Next Page)

## **FLIGHT INSTRUMENTS** (Continued)

### **HORIZONTAL SITUATION INDICATOR** (Continued)

The cyan HSI heading reference pointer, bug, is set using the HDG knob on the GDU display. The selected heading is shown digitally in a window above the upper left 45° index mark. The selected heading will provide control input to the autopilot, if installed, when engaged in HDG mode.

The CDI navigation source shown on the HSI is set using the CDI softkey to select from GPS, NAV 1 or NAV 2 inputs. The course reference pointer is set using the CRS knob on the GDU display. The selected course is shown digitally in a window above the upper right 45° index mark. The selected navigation source will provide control input to the autopilot, if installed, when engaged in NAV, APR or BC mode and it is receiving a navigation signal from the selected GPS or VHF NAV radios.

### **WARNING**

**WHEN THE AUTOPILOT IS ENGAGED IN NAV, APR OR BC OPERATING MODES, IF THE HSI NAVIGATION SOURCE IS CHANGED MANUALLY, USING THE CDI SOFTKEY OR SBAS IS UNAVAILABLE DURING A LP APPROACH (PRIOR TO FAF), THE NAVIGATION SIGNAL TO THE AUTOPILOT WILL BE INTERRUPTED AND CAUSE THE AUTOPILOT TO REVERT TO ROL MODE OPERATION. NO AURAL ALERT WILL BE PROVIDED. IN ROL MODE, THE AUTOPILOT WILL ONLY KEEP THE WINGS LEVEL AND WILL NOT CORRECT THE AIRPLANE HEADING OR COURSE. SET THE HDG BUG TO THE CORRECT HEADING AND VERIFY/SELECT THE CORRECT NAVIGATION SOURCE ON THE HSI BEFORE ENGAGING THE AUTOPILOT IN ANY OTHER OPERATING MODE.**

(Continued Next Page)

## **FLIGHT INSTRUMENTS** (Continued)

### **VERTICAL SPEED INDICATOR**

The Vertical Speed Indicator (VSI) tape is found on the right side of the altimeter display along the upper right side of the PFD. The vertical speed pointer moves up and down the fixed VSI scale and shows the rate of climb or descent in digits inside the pointer. The VSI tape has a notch on the right edge at the 0 feet/min index for reference. Rate of descent is shown with a negative sign in front of the digits. Vertical speed must exceed 100 feet/min in climb or descent before digits will appear in the VSI pointer.

### **GROUND CONTROL**

Effective ground control while taxiing is accomplished through nosewheel steering by using the rudder pedals; left rudder pedal to steer left and right rudder pedal to steer right. When a rudder pedal is depressed, a spring loaded steering bungee, which is connected to the nose gear and to the rudder bars, will turn the nosewheel through an arc of approximately 10° each side of center. By applying either left or right brake, the degree of turn may be increased up to 30° each side of center.

Moving the airplane by hand is most easily accomplished by attaching a towbar to the nose gear strut. If a towbar is not available, or pushing is required, use the wing struts as push points. Do not use the vertical or horizontal surfaces to move the airplane. If the airplane is to be towed by vehicle, never turn the nosewheel more than 30° either side of center or structural damage to the nose gear could result.

The minimum turning radius of the airplane, using differential braking and nosewheel steering during taxi, is approximately 27 feet. To obtain a minimum radius turn during ground handling, the airplane may be rotated around either main landing gear by pressing down on a tailcone bulkhead just forward of the horizontal stabilizer to raise the nosewheel off the ground. Care should be exercised to ensure that pressure is exerted only on the bulkhead area and not on skin between the bulkheads. Pressing down on the horizontal stabilizer to raise the nosewheel off the ground is not recommended.

## WING FLAP SYSTEM

The single slot type wing flaps, refer to Figure 7-3, are extended or retracted by positioning the wing flap control lever on the instrument panel to the desired flap deflection position. The wing flap control lever is moved up or down in a slotted panel that provides mechanical stops at the 10°, 20° and FULL positions. To change flap setting, the wing flap control lever is moved to the right to clear mechanical stops at the 10° and 20° positions. A scale and pointer to the left of the wing flap control lever indicates flap travel in degrees. The wing flap system circuit is protected by a 10-ampere circuit breaker, labeled FLAP, on the left side of the circuit breaker panel.

B3109

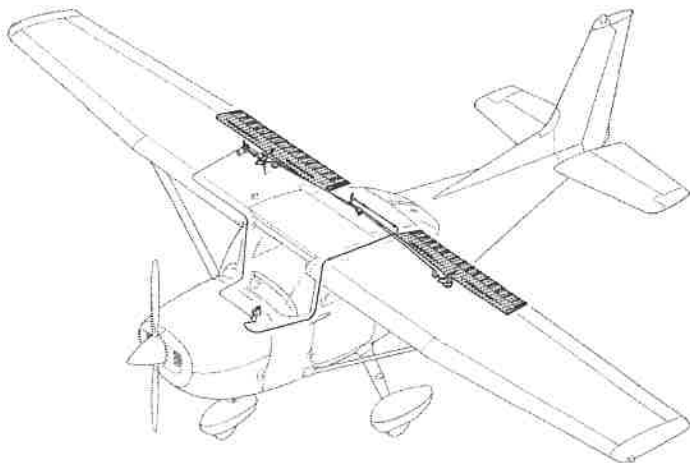

0585R1021

Figure 7-3

## LANDING GEAR SYSTEM

The landing gear is of the tricycle type, with a steerable nosewheel and two main wheels. Wheel fairings are standard equipment for both the main wheels and nosewheel. Shock absorption is provided by the tubular spring steel main landing gear struts and the air/oil nose gear shock strut. Each main gear wheel is equipped with a hydraulically-actuated disc type brake on the inboard side of each wheel.

## **BAGGAGE COMPARTMENT**

The baggage compartment consists of two areas, one extending from behind the rear passengers seat to the aft cabin bulkhead, and an additional area aft of the bulkhead. Access to both baggage areas is gained through a lockable baggage door on the left side of the airplane, or from within the airplane cabin. A baggage net with tiedown straps is provided for securing baggage and is attached by tying the straps to tiedown rings provided in the airplane. For baggage area and door dimensions, refer to Section 6.

## **SEATS**

The seating arrangement consists of two vertically adjusting crew seats for the pilot and front seat passenger, and a single bench seat with adjustable back for rear seat passengers.

Seats used for the pilot and front seat passenger are adjustable forward and aft, and up and down. Additionally, the angle of the seat back is infinitely adjustable.

Forward and aft adjustment is made using the handle located below the center of the seat frame. To position the seat, lift the handle, slide the seat into position, release the handle and check that the seat is locked in place. To adjust the height of the seat, rotate the large crank under the right corner of the seat until a comfortable height is obtained. To adjust the seat back angle, pull up on the release button, located in center front of seat, just under the seat bottom, position the seat back to the desired angle, and release the button. When the seat is not occupied, the seat back will automatically fold forward whenever the release button is pulled up.

The rear passenger seat consists of a fixed, one piece seat bottom and a three-position reclining back. The reclining back is adjusted by a lever located below the center of the seat frame. To adjust the seat back, raise the lever, position the seat back to the desired angle, release the lever, and check that the seat back is securely locked in place.

Headrests are installed on both the front and rear seats. To adjust the headrest, apply enough pressure to it to raise or lower it to the desired level.

## **INTEGRATED SEAT BELT/SHOULDER HARNESS**

All seat positions are equipped with integrated seat belts/shoulder harness assemblies, Refer to Figure 7-4. The design incorporates an overhead inertia reel for the shoulder portion, and a retractor assembly for the lap portion of the belt. This design allows for complete freedom of movement of the upper torso area while providing restraint in the lap belt area. In the event of a sudden deceleration, reels lock up to provide positive restraint for the user.

In the front seats, the inertia reels are located on the centerline of the upper cabin area. In the rear seats, the inertia reels are located outboard of each passenger in the upper cabin.

To use the integrated seat belt/shoulder harness, grasp the link with one hand, and, in a single motion, extend the assembly and insert into the buckle. Positive locking has occurred when a distinctive "snap" sound is heard.

Proper locking of the lap belt can be verified by ensuring that the belts are allowed to retract into the retractors and the lap belt is snug and low on the waist as worn normally during flight. No more than one additional inch of belt should be able to be pulled out of the retractor once the lap belt is in place on the occupant. If more than one additional inch of belt can be pulled out of the retractor, the occupant is too small for the installed restraint system and the seat should not be occupied until the occupant is properly restrained.

Removal is accomplished by pressing the release button on the buckle and pulling out and up on the harness. Spring tension on the inertia reel will automatically stow the harness.

# INTEGRATED SEAT BELT/SHOULDER HARNESS

B3998

Standard Integrated Seat  
Belt/Shoulder Harness with  
Inertia Reel

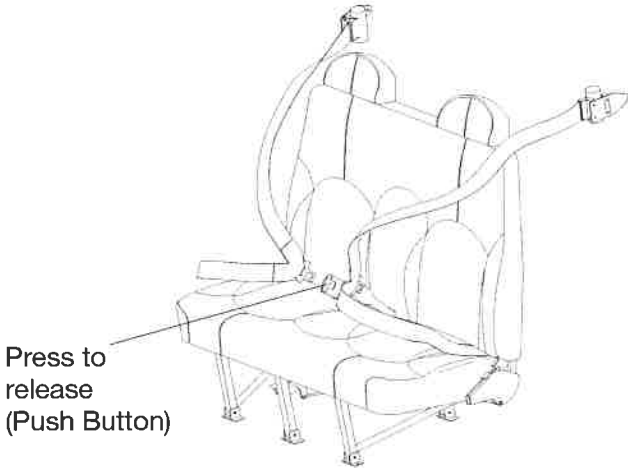
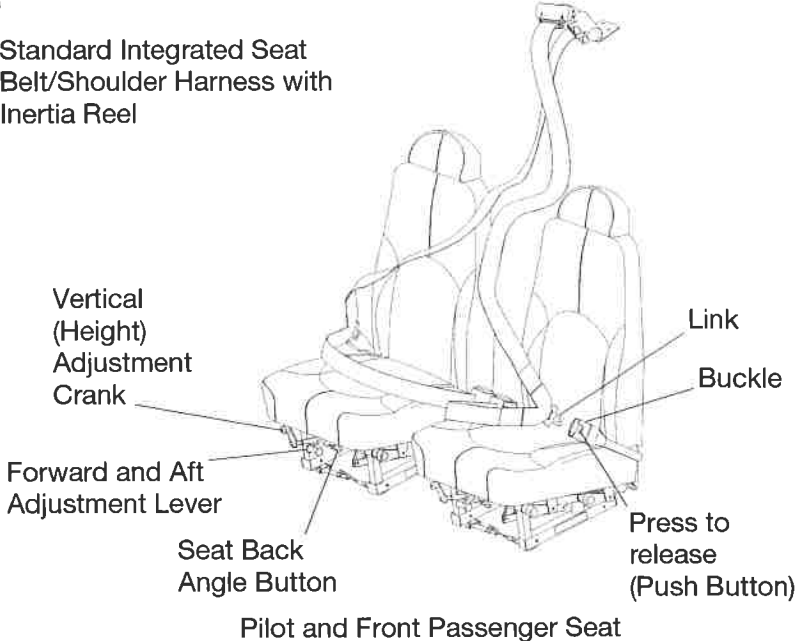

0519T1111  
0519T1112

Figure 7-4\*

## ENTRANCE DOORS AND CABIN WINDOWS

Entry to and exit from the airplane is accomplished through either of two entry doors, one on each side of the cabin, at the front seat positions, Refer to Section 6 for cabin and cabin door dimensions. The doors incorporate a recessed exterior door handle, a conventional interior door handle, a key operated door lock, left door only, a door stop mechanism, and openable windows in both the left and right doors.

### NOTE

The door latch design on this model requires that the outside door handle on the pilot and front passenger doors be extended out whenever the doors are open. When closing the door, do not attempt to push the door handle in until the door is fully shut.

To open the doors from outside the airplane, utilize the recessed door handle near the aft edge of either door by grasping the forward edge of the handle and pulling outboard. To close or open the doors from inside the airplane, use the combination door handle and arm rest. The inside door handle has three positions and a placard at its base which reads OPEN, CLOSE, and LOCK. The handle is spring loaded to the CLOSE (up) position. When the door has been pulled shut and latched, lock it by rotating the door handle forward to the LOCK position (flush with the arm rest). When the handle is rotated to the LOCK position, an over center action will hold it in that position. Both cabin doors should be locked prior to flight, and should not be opened intentionally during flight.

### NOTE

Accidental opening of a cabin door in flight, due to improper closing, does not constitute a need to land the airplane. The best procedure is to set up the airplane in a trimmed condition at approximately 75 KIAS, momentarily shove the door outward slightly, and forcefully close and lock the door.

(Continued Next Page)

## **ENTRANCE DOORS AND CABIN WINDOWS**

(Continued)

Exit from the airplane is accomplished by rotating the door handle from the LOCK position, past the CLOSE position, aft to the OPEN position and pushing the door open. To lock the airplane, lock the right cabin door with the inside handle, close the left cabin door, and using the ignition key, lock the door.

The left and right cabin doors are equipped with openable windows which are held in the closed position by a detent equipped latch on the lower edge of the window frame. To open the windows, rotate the latch upward. Each window is equipped with a spring-loaded retaining arm which will help rotate the window outward, and hold it there. If required, either window may be opened at any speed up to 163 KIAS. The rear side windows and rear windows are of the fixed type and cannot be opened.

## **CONTROL LOCKS**

A control lock is provided to lock the aileron and elevator control surfaces to prevent damage to these systems by wind buffeting while the airplane is parked. The lock consists of a shaped steel rod and flag. The flag identifies the control lock and cautions about its removal before starting the engine. To install the control lock, align the hole in the top of the pilot's control wheel shaft with the hole in the top of the shaft collar on the instrument panel and insert the rod into the aligned holes. Installation of the lock will secure the ailerons in a neutral position and the elevators in a slightly trailing edge down position. Proper installation of the lock will place the flag over the ignition switch. In areas where high or gusty winds occur, a control surface lock should be installed over the vertical stabilizer and rudder. The control lock and any other type of locking device should be removed prior to starting the engine.

## ENGINE

The airplane is powered by a direct drive, horizontally opposed, four cylinder, overhead valve, air cooled, fuel injected engine with a wet sump lubrication system. The engine is a Lycoming Model IO-360-L2A rated at 180 horsepower at 2700 RPM. Major accessories include a starter and belt driven alternator mounted on the front of the engine, dual magnetos, vacuum pump (if installed), engine driven fuel pump, and a full flow oil filter mounted on the rear of the engine accessory case.

## ENGINE CONTROLS

Engine power is set using the throttle control. The throttle control is a smooth black knob located at the center of the instrument panel below the standby instruments. The throttle control is configured so that the throttle is open in the forward position and closed in the full aft position. A friction lock, located at the base of the throttle, is operated by rotating the lock clockwise to increase friction or counterclockwise to decrease friction.

Engine fuel mixture is controlled by the mixture control. The mixture control is a red knob, with raised points around the circumference, located immediately to the right of the throttle control and is equipped with a lock button in the end of the knob. The rich position is full forward, and full aft is the idle cutoff position. For small adjustments, the control may be moved forward by rotating the knob clockwise, and aft by rotating the knob counterclockwise. For rapid or large adjustments, the knob may be moved forward or aft by depressing the lock button in the end of the control, and then positioning the control as desired.

(Continued Next Page)

## **ENGINE** (Continued)

### **ENGINE INSTRUMENTS**

The G1000 Engine Indication System (EIS) provides graphical indicators and numeric values for engine, fuel, and electrical system parameters to the pilot. The EIS is shown in a vertical strip on the left side of the PFD during engine starts and on the MFD during normal operation. If either the MFD or PFD fails during flight, the EIS is shown on the remaining display.

The EIS consists of three pages that are selected using the ENGINE softkey. The ENGINE page provides indicators for Tachometer (RPM), Fuel Flow (FFLOW GPH), Oil Pressure (OIL PRES), Oil Temperature (OIL TEMP), Exhaust Gas Temperature (EGT), Vacuum (VAC) (if installed), Fuel Quantity (FUEL QTY GAL), Engine Hours (ENG HRS), Electrical Bus Voltages (VOLTS), and Battery Currents (AMPS). When the ENGINE softkey is pressed, the LEAN and SYSTEM softkeys appear adjacent to the ENGINE softkey. The LEAN page provides simultaneous indicators for Exhaust Gas Temperature (EGT °F) and Cylinder Head Temperature (CHT °F) on all cylinders to be used for adjusting, or leaning, the fuel/air mixture along with a digital value for FFLOW GPH and an indicator for FUEL QTY GAL. The SYSTEM page provides numerical values for parameters on the ENGINE page that are shown as indicators only. The SYSTEM page also provides a digital value for Fuel Used (GAL USED) and Fuel Remaining (GAL REM).

The engine and airframe unit, located forward of the instrument panel, receives signals from the engine/system sensors for the parameters that are being monitored. The engine and airframe unit provides data to the EIS, which displays the data for the ENGINE page described on the following pages.

(Continued Next Page)

## **ENGINE** (Continued)

### **ENGINE INSTRUMENTS** (Continued)

#### **RPM (TACHOMETER)**

Engine speed (RPM) is shown by the tachometer indicator found on all EIS pages. The tachometer indicator uses a circular scale with moving pointer and a digital value. The pointer moves through a range from 0 to 3000 RPM. The numerical RPM value is displayed in increments of 10 RPM in white numerals below the pointer.

The normal engine speed operating limit (top of green arc) changes with altitude. For standard-day conditions, between sea level and 5000 feet, 2500 RPM is the upper limit of the normal operating range. From 5000 feet to 10,000 feet, 2600 RPM is the top of the normal range. And above 10,000 feet, 2700 RPM is the upper limit of the normal operating range.

When engine speed is 2780 RPM or more, the pointer, digital value, and label (RPM) turn red to show engine speed is more than the limit. The digital value and label (RPM) will flash. The engine speed (tachometer) is displayed in the same configuration and location on the LEAN and SYSTEM pages. If engine speed becomes 2780 RPM or more, while on the LEAN or SYSTEM page, the display will return to the ENGINE page.

A speed sensor, mounted on the engine tachometer drive accessory pad, provides a digital signal to the engine and airframe unit which processes and outputs the RPM data to the EIS. A red X through the RPM indicator shows the indicating system is inoperative.

(Continued Next Page)

## **ENGINE** (Continued)

### **ENGINE INSTRUMENTS** (Continued)

#### **FUEL FLOW**

Fuel flow is shown on the ENGINE page by the FFLOW GPH horizontal indicator. The indicator range is from 0 to 20 gallons per hour (GPH) with 2 GPH graduations, with a green band from 0 to 12 GPH. A white pointer shows the measured fuel flow.

A digital value for FFLOW GPH is included on both the EIS LEAN and SYSTEM pages.

The fuel flow transducer is located in the engine fuel injection system between the fuel/air control unit (servo) and the fuel distribution manifold (flow divider). The transducer provides a signal to the engine display that is processed and shown as fuel flow (FFLOW) on the EIS pages. A red X through the indicator means the indicating system is inoperative.

#### **OIL PRESSURE**

Engine oil pressure is shown on the ENGINE page by the OIL PRES horizontal indicator. The indicator range is 0 to 120 PSI with a red band from 0 to 20 PSI, a green band from 50 to 90 PSI (normal operating range) and a red band from 115 to 120 PSI. A white pointer indicates actual oil pressure. Oil pressure is shown numerically on the SYSTEM page.

When oil pressure is 0 to 20 PSI or 115 to 120 PSI, the pointer, digital value, and label (OIL PRES) will change to red to show that oil pressure is outside normal limits. If oil pressure exceeds either the upper or lower limit while on the LEAN or SYSTEM page, the EIS will return to the ENGINE page.

When the engine speed (RPM) is in the green arc and the oil temperature is in the green band, the oil pressure should be in the green band. If oil pressure is below the green band or above the green band, adjust the engine speed to maintain adequate oil pressure. When engine speed is at idle or near idle, the oil pressure indication must be above the lower red band. With the engine at normal operating oil temperature, and engine speed at or close to idle, oil pressure below the green band, but above the lower red band, is acceptable.

(Continued Next Page)

## **ENGINE** (Continued)

### **ENGINE INSTRUMENTS** (Continued)

#### **OIL PRESSURE** (Continued)

In cold weather, the oil pressure will initially be high (close to the upper red band when the engine is started). As the engine and oil warm up, the oil pressure will come down into the green band range.

The oil pressure transducer, connected to the engine forward oil pressure port, provides a signal to the engine display that is processed and shown as oil pressure. A separate low oil pressure switch causes an OIL PRESSURE annunciation on the PFD when oil pressure is 0 to 20 PSI. A red X through the oil pressure indicator means that the indicating system is inoperative.

#### **OIL TEMPERATURE**

Engine oil temperature is shown on the ENGINE page by the OIL TEMP horizontal indicator. The indicator range is from 75°F to 250°F with a green band (normal operating range) from 100°F to 245°F and a red band from 245°F to 250°F. A white pointer indicates actual oil temperature. Oil temperature is displayed numerically on the SYSTEM page.

When oil temperature is in the red band, 245°F to 250°F, the pointer and OIL TEMP turn red and flash to show oil temperature is higher than the limit. If oil temperature becomes hotter than 245°F while on the LEAN or SYSTEM page, the display will default to the ENGINE page.

The oil temperature sensor is installed in the engine oil filter adapter and provides a signal to the engine display that is processed and shown as oil temperature. A red X through the indicator shows that the indicating system is inoperative.

(Continued Next Page)

## **ENGINE** (Continued)

### **ENGINE INSTRUMENTS** (Continued)

#### **CYLINDER HEAD TEMPERATURE**

Cylinder head temperature (CHT) for all four cylinders are shown on the LEAN page. The cylinder with the hottest CHT is indicated by a cyan bar graph. The indicator range is from 100°F to 500°F with a normal operating range from 200°F to 500°F and a warning range (red line) at 500°F. When the CHT is 500°F or hotter, the bar segments, CHT label and °F digital value will change to red to show that the CHT is greater than the limit.

A thermocouple is installed in each cylinder head and provides a signal to the engine display that is processed and shown as CHT on the EIS LEAN page. The LEAN page will show a red X over any cylinder that has a probe or wiring failure.

#### **EXHAUST GAS TEMPERATURE**

Exhaust gas temperature (EGT) is shown on the ENGINE page by the EGT horizontal indicator. The indicator range is from 1250°F to 1650°F with graduations every 50°F. The white pointer indicates relative EGT with the number of the hottest cylinder displayed inside the pointer. If a cylinder EGT probe or wiring failure occurs for the hottest EGT, the next hottest EGT will be displayed.

The EGT for all four cylinders is shown on the LEAN page of the EIS. The hottest cylinder is indicated by the cyan bar graph. The EGT for a particular cylinder may be shown by using the CYL SLCT softkey to select the desired cylinder. Automatic indication of the hottest cylinder will resume a short time after the CYL SLCT is last selected. The LEAN page will show a red X over a cylinder that has a probe or wiring failure.

A thermocouple is installed in the exhaust pipe of each cylinder which measures EGT and provides a signal to the engine display that is processed and shown as EGT on the EIS LEAN page.

(Continued Next Page)

## **ENGINE** (Continued)

### **NEW ENGINE BREAK-IN AND OPERATION**

The engine run-in was accomplished at the factory and is ready for the full range of use. It is suggested that cruising be accomplished at 75% power as much as practicable until a total of 50 hours has accumulated or oil consumption has stabilized. This will ensure proper seating of the piston rings.

### **ENGINE LUBRICATION SYSTEM**

The engine utilizes a full pressure, wet sump type lubrication system with aviation grade oil as the lubricant. The capacity of the engine sump, located on the bottom of the engine, is eight quarts with one additional quart contained in the engine oil filter. Oil is drawn from the sump through a filter screen on the end of a pickup tube to the engine driven oil pump. Oil from the pump passes through a full-flow oil filter, a pressure relief valve at the rear of the right oil gallery, and a thermostatically controlled remote oil cooler. Oil from the remote cooler is then circulated to the left oil gallery. The engine parts are then lubricated by oil from the galleries. After lubricating the engine, the oil returns to the sump by gravity. The filter adapter in the full-flow filter is equipped with a bypass valve which will cause lubricating oil to bypass the filter in the event the filter becomes plugged, or the oil temperature is extremely cold.

An oil dipstick/filler tube is located at the right rear of the engine case. The oil dipstick/filler tube is accessed through a door located on the right side of the engine cowling. The engine should not be operated on less than five quarts of oil. To minimize loss of oil through the breather, fill to eight quarts for normal flights of less than three hours. For extended flight, fill to eight quarts (dipstick indication only). For engine oil grade and specifications, refer to Section 8 of this POH.

(Continued Next Page)

## **ENGINE** (Continued)

### **IGNITION AND STARTER SYSTEM**

Engine ignition is provided by two engine driven magnetos, and two spark plugs in each cylinder. The left magneto fires the upper left and lower right spark plugs, and the right magneto fires the lower left and upper right spark plugs. Normal operation is conducted with both magnetos due to the more complete burning of the fuel/air mixture with dual ignition.

Ignition and starter operation is controlled by a rotary-type switch located on the left switch and control panel. The MAGNETOS switch is labeled clockwise, OFF, R, L, BOTH, and START. The engine should be operated on both magnetos (BOTH position) except for magneto checks. The R and L positions are for checking purposes and emergency use only. When the MAGNETOS switch is rotated to the spring-loaded START position, with the MASTER switch in the ON position, the starter contactor is closed and the starter, now energized, will crank the engine. When the switch is released, it will automatically return to the BOTH position.

### **AIR INDUCTION SYSTEM**

The engine air induction system receives ram air through an intake on the lower front portion of the engine cowling. The intake is covered by an air filter which removes dust and other foreign matter from the induction air. Airflow passing through the filter enters an air box, which is equipped with a spring-loaded alternate air door. If the air induction filter should become blocked, suction created by the engine will open the door and draw unfiltered air from inside the lower cowl area. An open alternate air door will result in an approximate 10% power loss at full throttle. After passing through the air box, induction air enters a fuel/air control unit under the engine, and is then ducted to the engine cylinders through intake manifold tubes.

(Continued Next Page)

## **ENGINE** (Continued)

### **EXHAUST SYSTEM**

Exhaust gas from each cylinder passes through a riser assembly to a common muffler, located below the engine, and then overboard through a single tailpipe. Outside air is supplied to a shroud constructed around the outside of the muffler to form a heating chamber. The air heated by the shroud is then supplied to the cabin.

### **FUEL INJECTION SYSTEM**

The engine is equipped with a fuel injection system. The system is comprised of an engine driven fuel pump, fuel/air control unit, fuel manifold, fuel flow indicator, and air-bleed type injector nozzles.

Fuel is delivered by the engine driven fuel pump to the fuel/air control unit. The fuel/air control unit correctly proportions the fuel flow to the induction air flow. After passing through the control unit, induction air is delivered to the cylinders through the intake manifold tubes and metered fuel is delivered to a fuel manifold (flow divider). The fuel manifold, through spring tension on a diaphragm and valve, evenly distributes the fuel to an air-bleed type injector nozzle in the intake valve chamber of each cylinder. A turbine-type fuel flow transducer mounted between the fuel/air control unit and the fuel distribution unit produces a digital signal that displays fuel flow on the EIS pages.

### **COOLING SYSTEM**

Ram air for engine cooling enters through two intake openings in the front of the engine cowling. The cooling air is directed from above the engine, around the cylinders and other areas of the engine by baffling, and then exits through an opening at the bottom aft edge of the engine cowling.

A winterization kit is available for the airplane. Refer to Section 9, Supplement 4 for description and operating information.

### **PROPELLER**

The airplane is equipped with a two bladed, fixed pitch, one-piece forged aluminum alloy propeller which is anodized to retard corrosion. The propeller is 76 inches in diameter.

## FUEL SYSTEM

The airplane fuel system, refer to Figure 7-6, consists of two vented integral fuel tanks (one tank in each wing), three-position selector valve, fuel reservoir tank, electrically-driven auxiliary fuel pump, fuel shutoff valve, and a fuel strainer. The engine-mounted portion of the system consists of the engine driven fuel pump, a fuel/air control unit, fuel flow transducer, a fuel distribution valve (flow divider) and fuel injection nozzles.

### WARNING

**UNUSABLE FUEL LEVELS FOR THIS AIRPLANE WERE DETERMINED IN ACCORDANCE WITH FEDERAL AVIATION REGULATIONS. FAILURE TO OPERATE THE AIRPLANE IN COMPLIANCE WITH FUEL LIMITATIONS SPECIFIED IN SECTION 2 MAY FURTHER REDUCE THE AMOUNT OF FUEL AVAILABLE IN FLIGHT.**

### FUEL QUANTITY DATA IN U.S. GALLONS

FUEL TANKS	FUEL LEVEL (QUANTITY EACH TANK)	TOTAL FUEL	TOTAL UNUSABLE	TOTAL USABLE ALL FLIGHT CONDITIONS
Two	Full (28.0)	56.0	3.0	53.0
Two	Reduced (19.0)	38.0	3.0	35.0

Figure 7-5

(Continued Next Page)

## **FUEL SYSTEM** (Continued)

### **FUEL DISTRIBUTION**

Fuel flows by gravity from the two wing tanks to a three-position fuel selector valve, labeled BOTH, RIGHT and LEFT, and on to the fuel reservoir tank. From the fuel reservoir tank, fuel flows through the electrically-driven auxiliary fuel pump, through the fuel shutoff valve, the fuel strainer, and to the engine-driven fuel pump. From the engine-driven fuel pump, fuel is delivered to the fuel/air control unit on the bottom of the engine. The fuel/air control unit (fuel servo) meters fuel flow in proportion to induction air flow. After passing through the control unit, metered fuel goes to a fuel distribution valve (flow divider) located on the top of the engine. From the fuel distribution valve, individual fuel lines are routed to air bleed type injector nozzles located in the intake chamber of each cylinder.

### **FUEL INDICATING SYSTEM**

Fuel quantity is measured by two fuel quantity sensors, one in each fuel tank, and is displayed on the EIS pages. The indicators are marked in gallons of fuel (GAL). An empty tank is displayed on the fuel quantity indicator (FUEL QTY GAL) as a red line on the far left of the indicator scale, and the number 0. When an indicator shows an empty tank, approximately 1.5 gallons of unusable fuel remain in the tank. The indicators should not be relied upon for accurate readings during skids, slips or unusual attitudes.

The fuel quantity indicator shows the fuel available in the tank up to the limit of the sensor measurement range. At this level, additional fuel may be added to completely fill the tank, but no additional movement of the indicator will result. The limit for sensor measurement range is approximately 24 gallons and is indicated by the maximum limit of the green band. When the fuel level decreases below the maximum limit of the fuel sensor, the fuel quantity indicator will display fuel quantity measured in each tank. A visual check of each wing tank fuel level must be performed prior to each flight. Compare the visual fuel level and indicated fuel quantity to accurately estimate usable fuel.

(Continued Next Page)

## **FUEL SYSTEM** (Continued)

### **FUEL INDICATING SYSTEM** (Continued)

The fuel quantity indicators detect low fuel conditions and incorrect sensor outputs. When fuel quantity is less than 5 gallons indicated (and remains less than this level for more than 60 seconds), LOW FUEL L (left) and/or LOW FUEL R (right) will be displayed in amber on the PFD and a tone will sound. The fuel quantity indicator pointer(s) and indicator label will change from white to steady amber. When fuel quantity reaches the calibrated usable fuel empty level, the LOW FUEL L and/or LOW FUEL R remain amber and the indicator pointer(s) and label change to flashing red.

#### **NOTE**

Takeoff is not recommended if both fuel quantity indicator pointers are in the yellow band range and/or amber LOW FUEL L or LOW FUEL R annunciator is displayed on the PFD.

In addition to low fuel annunciation, the warning logic is designed to report failures with each sensor. If the system detects a failure, the affected fuel indicator will display a red X. A red X through the top part of the indicator indicates a failure associated with the left fuel tank. A red X through the bottom part of the indicator indicates a failure associated with the right fuel tank.

Fuel flow is measured by use of a turbine type transducer mounted on top of the engine between the fuel/air control unit and the fuel distribution unit. This flow meter produces a signal that is displayed as the rate of fuel flow on the FFLOW GPH indicator on the EIS pages. FFLOW GPH is shown as either a horizontal analog indicator or a digital value, depending on the active EIS page.

(Continued Next Page)

## **FUEL SYSTEM** (Continued)

### **FUEL CALCULATIONS**

#### **NOTE**

Fuel calculations do not use the airplane's fuel quantity indicators and are calculated from the last time the fuel was reset.

For fuel consumption information, a fuel used totalizer function is provided on the EIS SYSTEM page as GAL USED. This digital indicator shows total fuel used since last reset of the totalizer. To reset the GAL USED, the EIS SYSTEM page must be active and the RST USED softkey must be selected. GAL USED is calculated after reset using information from the fuel flow transducer signal.

For fuel remaining information, a count down fuel totalizer function is provided on the EIS SYSTEM page as GAL REM. This digital indicator shows calculated fuel remaining since last GAL REM pilot adjustment. To adjust GAL REM, the EIS SYSTEM page must be active and the GAL REM softkey must be selected followed by the appropriate quantity adjustment softkeys. Refer to the Garmin G1000 CRG for details for resetting and adjusting fuel calculations. GAL REM is calculated after pilot adjustment using information from the fuel flow transducer signal.

#### **NOTE**

GAL USED and GAL REM provide no indication of the actual amount of fuel remaining in each tank and should only be used in conjunction with other fuel management procedures to estimate total fuel remaining.

(Continued Next Page)

**FUEL SYSTEM** (Continued)

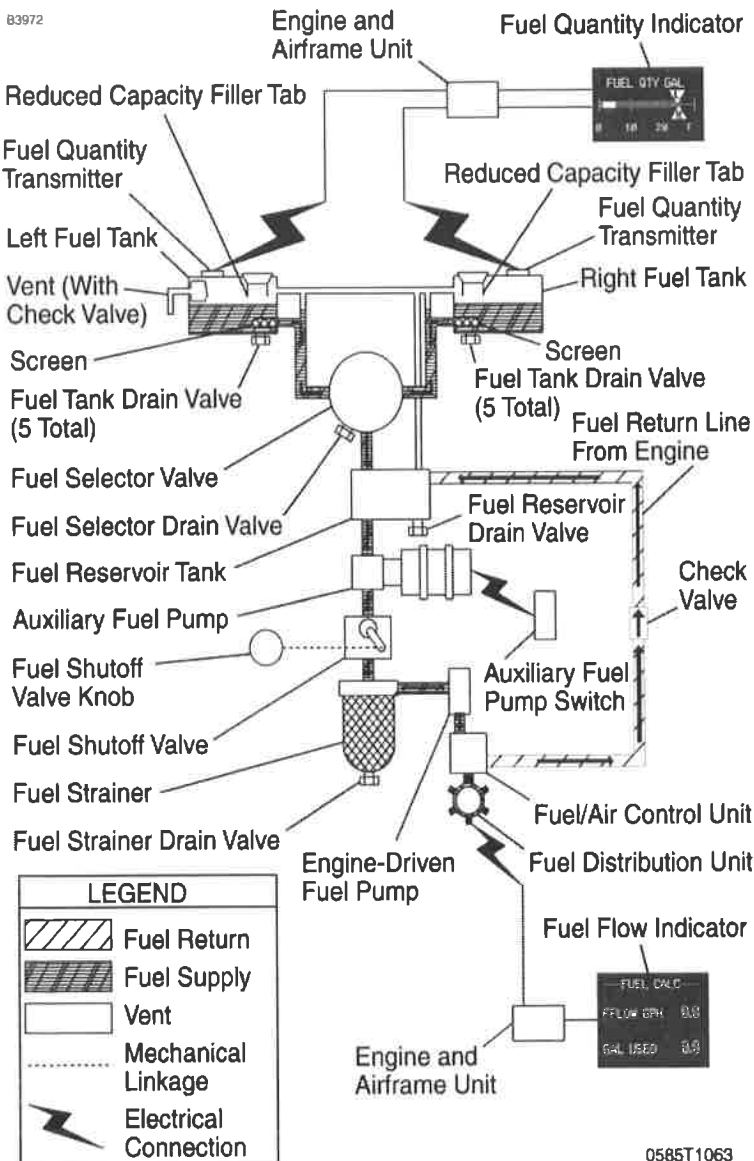

0585T1063

Figure 7-6

## **FUEL SYSTEM** (Continued)

### **AUXILIARY FUEL PUMP OPERATION**

The auxiliary fuel pump is used primarily for priming the engine before starting. Priming is accomplished through the fuel injection system. The engine may be flooded if the auxiliary FUEL PUMP switch is accidentally placed in the ON position for prolonged periods, with MASTER Switch ON and mixture rich, with the engine stopped.

The auxiliary fuel pump is also used for vapor suppression in hot weather. Normally, momentary use will be sufficient for vapor suppression; however, continuous operation is permissible if required. Turning on the auxiliary fuel pump with a normally operating engine-driven fuel pump will result in only a very minor enrichment of the mixture.

It is not necessary to operate the auxiliary fuel pump during normal takeoff and landing, since gravity and the engine-driven fuel pump will supply adequate fuel flow. In the event of failure of the engine-driven fuel pump, use of the auxiliary fuel pump will provide sufficient fuel to maintain flight at maximum continuous power.

Under hot day, high altitude conditions, or conditions during a climb that are conducive to fuel vapor formation, it may be necessary to utilize the auxiliary fuel pump to attain or stabilize the fuel flow required for the type of climb being performed. In this case, turn the auxiliary fuel pump on, and adjust the mixture to the desired fuel flow. If fluctuating fuel flow (greater than 1 GPH) is observed during climb or cruise at high altitudes on hot days, place the auxiliary fuel pump switch in the ON position to clear the fuel system of vapor. The auxiliary fuel pump may be operated continuously in cruise.

(Continued Next Page)

## **FUEL SYSTEM** (Continued)

### **FUEL RETURN SYSTEM**

A fuel return system was incorporated to improve engine operation during extended idle operation in hot weather environments. The major components of the system include an orifice fitting located in the top of the fuel-air control unit (fuel servo), fuel return line, with check valve, and a fuel reservoir tank. The fuel return system is designed to return a metered amount of fuel/vapor back to the fuel reservoir tank. The increased fuel flow, due to the fuel return system, results in lower fuel operating temperatures at the engine inlet, which minimizes the amount of fuel vapor generated in the fuel lines during hot weather operations. Refer to Section 4 for Hot Weather operating information.

### **FUEL VENTING**

Fuel system venting is essential to system operation. Complete blockage of the fuel venting system will result in decreasing fuel flow and eventual engine stoppage. The fuel venting system consists of an interconnecting vent line between the fuel tanks and a check valve equipped overboard vent in the left fuel tank assembly. The overboard vent protrudes from the bottom surface of the left wing, just inboard of the wing strut upper attachment point. The fuel filler caps are vacuum vented; the fuel filler cap vents will open and allow air to enter the fuel tanks in case the overboard vents become blocked.

### **REDUCED TANK CAPACITY**

The airplane may be serviced to a reduced capacity to permit heavier cabin loadings. This is accomplished by filling each tank to the bottom edge of the fuel filler indicator tab, thus giving a reduced fuel load of 17.5 gallons usable in each tank.

(Continued Next Page)

## **FUEL SYSTEM** (Continued)

### **FUEL SELECTOR VALVE**

The fuel selector is a three-position selector valve, labeled BOTH, RIGHT and LEFT. The fuel selector valve should be in the BOTH position for takeoff, climb, landing, and maneuvers that involve prolonged slips or skids of more than 30 seconds. Operation on either LEFT or RIGHT fuel tank is reserved for level cruising flight only.

#### **NOTE**

- When the fuel selector valve is placed in the BOTH position, while in cruise flight, unequal fuel flow from each tank may occur if the wings are not maintained exactly level. Unequal fuel flow can be detected by one fuel tank indicating more fuel than the other on the L FUEL and R FUEL indicators. The resulting fuel imbalance can be corrected by turning the fuel selector valve to the fuel tank indicating the highest fuel quantity. Once the L FUEL and R FUEL indicators have equalized, position the fuel selector valve to the BOTH position.
- It is not practical to measure the time required to consume all of the fuel in one tank, and, after switching to the opposite tank, expect an equal duration from the remaining fuel. The airspace in both fuel tanks is interconnected by a vent line and, therefore, some sloshing of fuel between tanks can be expected when the tanks are nearly full and the wings are not level.
- When the fuel tanks are 1/4 tank or less, prolonged uncoordinated flight, such as slips or skids, can uncover the fuel tank outlets causing fuel starvation and engine stoppage. Therefore, if operating with one fuel tank dry or operating on either LEFT or RIGHT tank with 1/4 tank or less, do not allow the airplane to remain in uncoordinated flight for periods in excess of 30 seconds.

(Continued Next Page)

## **FUEL SYSTEM** (Continued)

### **FUEL DRAIN VALVES**

The fuel system is equipped with drain valves to provide a means for the examination of fuel in the system for contamination and grade. The system should be examined before each flight and after each refueling, by using the sampler cup provided to drain fuel from each wing tank sump, the fuel reservoir tank sump, the fuel selector valve drain and the fuel strainer sump. If any evidence of fuel contamination is found, it must be eliminated in accordance with the preflight inspection checklist and the discussion in Section 8. If takeoff weight limitations for the next flight permit, the fuel tanks should be filled after each flight to prevent condensation.

### **BRAKE SYSTEM**

The airplane has a single-disc, hydraulically-actuated brake on each main landing gear wheel. Each brake is connected, by a hydraulic line, to a master cylinder attached to each of the pilot's rudder pedals. The brakes are operated by applying pressure to the top of either the left (pilot's) or right (copilot's) set of rudder pedals, which are interconnected. When the airplane is parked, both main wheel brakes may be set by utilizing the parking brake which is operated by a handle under the left side of the instrument panel. To apply the parking brake, set the brakes with the rudder pedals, pull the handle aft, and rotate it 90° down.

For maximum brake life, keep the brake system properly maintained, and minimize brake usage during taxi operations and landings.

Some of the symptoms of impending brake failure are: gradual decrease in braking action after brake application, noisy or dragging brakes, soft or spongy pedals, and excessive travel and weak braking action. If any of these symptoms appear, the brake system is in need of immediate attention. If, during taxi or landing roll, braking action decreases, let up on the pedals and then reapply the brakes with heavy pressure. If the brakes become spongy or pedal travel increases, pumping the pedals should build braking pressure. If one brake becomes weak or fails, use the other brake sparingly while using opposite rudder, as required, to offset the good brake

## **ELECTRICAL SYSTEM**

The airplane is equipped with a 28-volt direct current (DC) electrical system, Refer to Figure 7-7. A belt-driven 60 ampere alternator powers the system. A 24-volt main storage battery is located inside the engine cowling on the left firewall. The alternator and main battery are controlled through the MASTER switch found near the top of the pilot's switch panel.

Power is supplied to most electrical circuits through two primary buses (ELECTRICAL BUS 1 and ELECTRICAL BUS 2), with an essential bus and a crossfeed bus connected between the two primary buses to support essential equipment.

The system is equipped with a secondary or standby battery located between the firewall and the instrument panel. The STBY BATT switch controls power to or from the standby battery. The standby battery is available to supply power to the essential bus in the event that alternator and main battery power sources have both failed.

The primary buses are supplied with power whenever the MASTER switch is turned on, and are not affected by starter or external power usage. Each primary bus is also connected to an avionics bus through a circuit breaker and the AVIONICS BUS 1 and BUS 2 switches. Each avionics bus is powered when the MASTER switch and the corresponding AVIONICS switch are in the ON position.

### **CAUTION**

**BOTH BUS 1 AND BUS 2 AVIONICS SWITCHES SHOULD BE TURNED OFF TO PREVENT ANY HARMFUL TRANSIENT VOLTAGE FROM DAMAGING THE AVIONICS EQUIPMENT PRIOR TO TURNING THE MASTER SWITCH ON OR OFF, STARTING THE ENGINE OR APPLYING AN EXTERNAL POWER SOURCE.**

The airplane includes a power distribution module, located on the left forward side of the firewall, to house all the relays used in the airplane electrical system. The Alternator Control Unit (ACU), main battery current sensor, and the external power connector are also housed within the module.

(Continued Next Page)



**ELECTRICAL SYSTEM (Continued)**

B22080

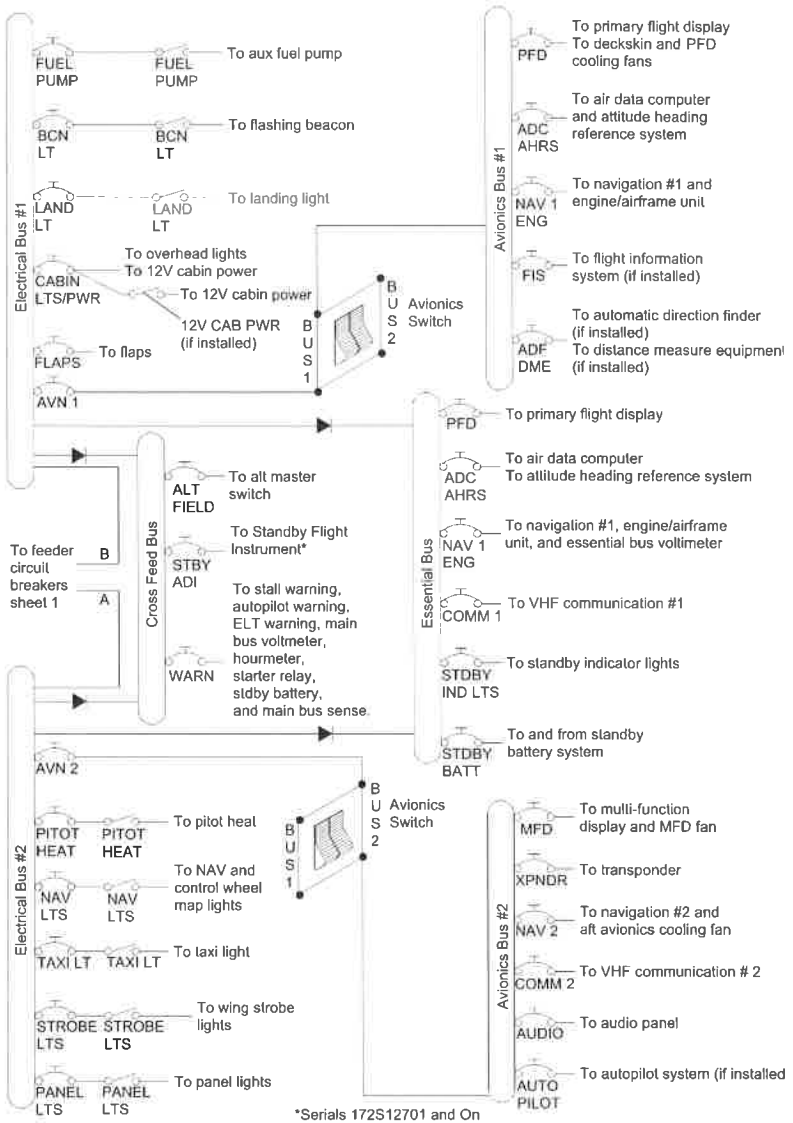
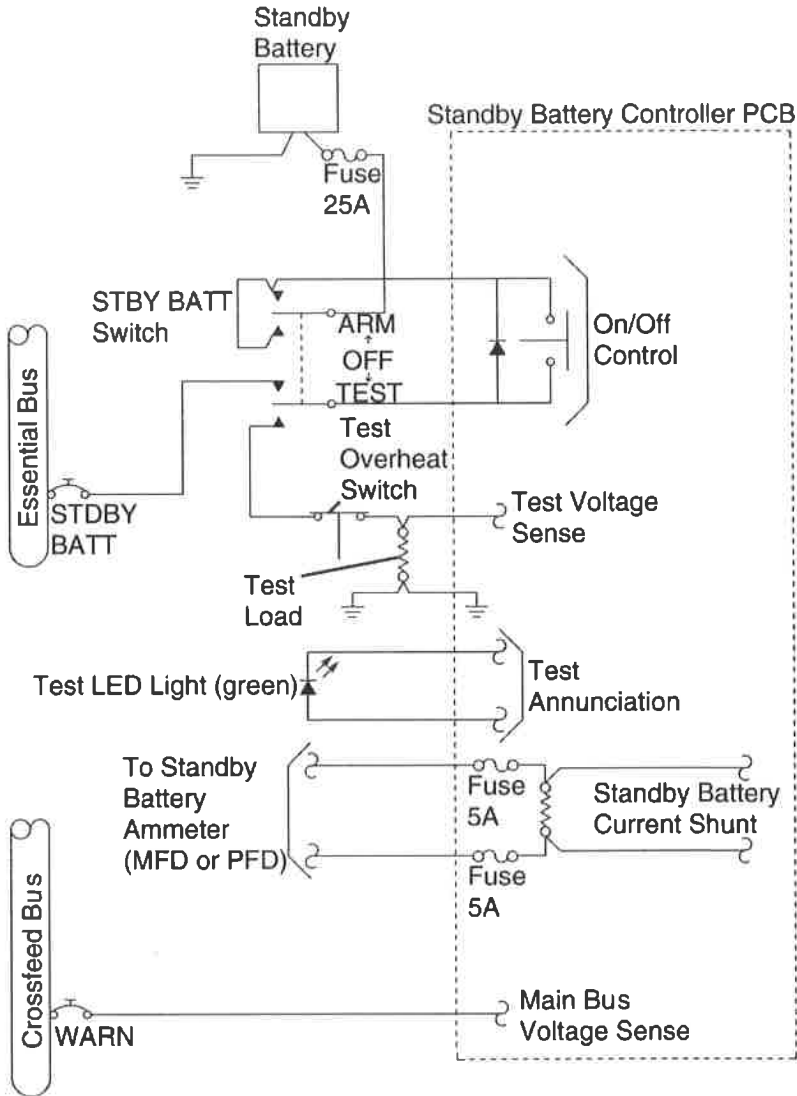

Figure 7-7\* (Sheet 2)

### ELECTRICAL SYSTEM (Continued)

B3766



0770T1519

Figure 7-7 (Sheet 3)

## **ELECTRICAL SYSTEM** (Continued)

### **G1000 ANNUNCIATOR PANEL**

All system alerts, cautions and warnings are shown on the right side of the PFD screen adjacent to the vertical speed indicator. The following annunciations are supported:

OIL PRESSURE	LOW VACUUM (if installed)
LOW FUEL L	LOW FUEL R
LOW VOLTS	HIGH VOLTS
STBY BATT	CO LVL HIGH

Refer to the Garmin G1000 CRG Appendix A for more information on system annunciations.

### **MASTER SWITCH**

The MASTER switch is a two-pole, rocker-type switch. The BAT side of the switch controls the main battery electrical power to the airplane. The ALT side of the switch controls the alternator system.

In normal operation, both sides of the switch (ALT and BAT) are ON simultaneously; however, the BAT side of the switch may be selected separately as necessary. The ALT side of the switch can not be set to ON without the BAT side of the switch also being set to ON.

If the alternator system fails, the MASTER switch may be set in the OFF position to preserve main battery capacity for later in the flight. With the MASTER switch OFF and the STBY BATT switch in the ARM position, the standby battery will power the essential bus for a limited time. Time remaining may be estimated by monitoring essential bus voltage. At 20 Volts, the standby battery has little or no capacity remaining.

(Continued Next Page)

## **ELECTRICAL SYSTEM** (Continued)

### **STANDBY BATTERY SWITCH**

The STBY BATT master switch is a three position (ARM-OFF-TEST) switch that tests and controls the standby battery system. The energy level of the battery shall be checked before starting the engine. Refer to Section 4, by placing the switch in the momentary TEST position and observing the correct illumination of the TEST lamp found to the right of the switch. Energy level tests after starting engine are not recommended.

Placing the switch in the ARM position during the engine start cycle allows the standby battery to help regulate and filter essential bus voltage during the start cycle. The switch is set to the ARM position during normal flight operation to allow the standby battery to charge and to be ready to power the essential bus in the event of alternator and main battery failure. Placing the switch in the OFF position disconnects the standby battery from the essential bus. Operation with the STBY BATT switch in the OFF position prevents the standby battery from charging and from automatically providing power should an electrical system failure occur.

### **AVIONICS SWITCH**

The AVIONICS switch is a two-pole rocker-type switch that controls electrical power to AVIONICS BUS 1 and BUS 2. Placing either side of the rocker switch in the ON position supplies power to the corresponding avionics bus. Both sides of the AVIONICS switch should be placed in the OFF position before turning the MASTER switch ON or OFF, starting the engine, or applying an external power source.

(Continued Next Page)

## **ELECTRICAL SYSTEM** (Continued)

### **ELECTRICAL SYSTEM MONITORING AND ANNUNCIATIONS**

#### **BUS VOLTAGE (VOLTMETERS)**

Voltage indication (VOLTS) for the main and essential buses is provided at the bottom of the EIS bar, along the left margin of the MFD or PFD, labeled M BUS E. Main bus voltage is shown numerically below the M. Essential bus voltage is displayed numerically below the E. The main bus voltage is measured at the WARN circuit breaker on the crossfeed bus. The essential bus voltage is measured at the NAV1 ENG circuit breaker on the essential bus.

Normal bus voltages with the alternator operating shall be about 28.0 volts. When the voltage for either main or essential buses is above 32.0 volts, the numerical value and VOLTS text turns red. This warning indication, along with the HIGH VOLTS annunciation, is an indication that the alternator is supplying too high of a voltage. The ALT MASTER Switch should immediately be positioned to OFF (Refer to Section 3, Emergency Procedures, HIGH VOLTS ANNUNCIATOR COMES ON).

When the voltage for either main or essential buses is below 24.5 volts, the numeric value and VOLTS text turns red. This warning indication, along with the LOW VOLTS annunciation, is an indication that the alternator is not supplying all the power that is required by the airplane. Indicated voltages between 24.5 and 28.0 volts may occur during low engine RPM conditions. Refer to note under LOW VOLTAGE ANNUNCIATION.

(Continued Next Page)

## **ELECTRICAL SYSTEM** (Continued)

### **ELECTRICAL SYSTEM MONITORING AND ANNUNCIATIONS** (Continued)

#### **AMMETERS**

Current indication (AMPS) for both the main and standby batteries is provided at the bottom of the EIS bar, along the left margin of the MFD or PFD, labeled M BATT S. Main battery current is numerically displayed below the M. Main battery current greater than -1.5 amps is shown in white. Standby battery current is displayed numerically below the S. A positive current value (shown in white) indicates that the battery is charging. A negative current value (shown in amber) indicates that the battery is discharging. In the event the alternator is not functioning or the electrical load exceeds the output of the alternator, the main battery ammeter indicates the main battery discharge rate.

In the event that standby battery discharge is required, normal steady state discharge should be less than 4.0 amps. The STBY BATT annunciator will come on when discharge rates are greater than 0.5 amps for more than 10 seconds. After engine start, with the STBY BATT switch in the ARM position, the standby battery ammeter should indicate a charge showing correct charging of the standby battery system.

#### **STANDBY BATTERY ANNUNCIATION**

The STBY BATT annunciator will come on when discharge rates are greater than 0.5 amps for more than 10 seconds. This caution announcement is an indication that the alternator and the main battery are not supplying the power that is required by the essential bus. If the condition causing the caution can not be resolved, flight should be terminated as soon as practicable.

(Continued Next Page)

## **ELECTRICAL SYSTEM** (Continued)

### **ELECTRICAL SYSTEM MONITORING AND ANNUNCIATIONS** (Continued)

#### **LOW VOLTAGE ANNUNCIATION**

A signal from the ACU, located inside the power distribution module, provides the trigger for a red LOW VOLTS annunciation shown on the PFD. LOW VOLTS is displayed when the main bus voltage measured in the power distribution module is below 24.5 volts. The LOW VOLTS warning annunciation is an indication that the alternator is not supplying the power that is required by the airplane. If the conditions causing the LOW VOLTS warning can not be resolved, nonessential electrical loads should be eliminated and the flight should be terminated as soon as practicable.

#### **NOTE**

During low RPM operation, with a high electrical load on the system, such as during a low RPM taxi, the LOW VOLTS annunciation may come on, the bus voltage values may turn red, and main battery ammeter discharge indications may occur. Under these conditions, increase RPM or decrease electrical loads to reduce demand on the battery.

In the event an overvoltage condition (or other alternator fault) occurs, the ACU will automatically open the ALT FIELD circuit breaker, removing alternator field current and stopping alternator output. The main battery will then supply current to the electrical system as shown by a discharge (negative number) on the M BATT ammeter. The LOW VOLTS annunciator will come on when the system voltage drops below 24.5 volts. Set the ALT FIELD circuit breaker to the ON position (push in) to energize the ACU. If the warning annunciation goes out and the main battery (M BATT) ammeter indicates positive current, normal alternator charging has resumed. If the annunciator comes on again, or the ALT FIELD circuit breaker opens again, an alternator malfunction has occurred. If the circuit breaker opens again, do not SET it to the ON position again. Have a qualified technician determine the cause and correct the malfunction. Turn off nonessential electrical loads and land as soon as practicable.

(Continued Next Page)

## **ELECTRICAL SYSTEM** (Continued)

### **ELECTRICAL SYSTEM MONITORING AND ANNUNCIATIONS** (Continued)

#### **LOW VOLTAGE ANNUNCIATION** (Continued)

The ALT FIELD circuit breaker may open on occasion during normal engine starts due to transient voltages. Provided that normal alternator output is resumed after the ALT FIELD circuit breaker is reset, these occurrences are considered nuisance events. If the ALT FIELD circuit breaker opens after reset, do not close again. Repeated occurrences indicate a problem with the electrical system that must be corrected by a qualified maintenance technician before flight.

#### **HIGH VOLTAGE ANNUNCIATION**

The HIGH VOLTS annunciator will come on when main or essential bus voltage is above 32.0 volts. This warning annunciation is an indication that the alternator is supplying too high of a voltage. The ALT MASTER switch should immediately be positioned to OFF (Refer to Section 3, Emergency Procedures, HIGH VOLTS ANNUNCIATOR COMES ON).

In the event a HIGH VOLTS condition occurs, the ACU will automatically open the ALT FIELD circuit breaker, removing alternator field current and stopping alternator output. The HIGH VOLTS annunciator is a warning that the ACU automatic alternator shutdown circuit is not operational and an action from the pilot is required to position the ALT MASTER to OFF.

(Continued Next Page)

## **ELECTRICAL SYSTEM** (Continued)

### **CIRCUIT BREAKERS AND FUSES**

Individual system circuit breakers are found on the circuit breaker panel below the pilot's control wheel. All circuit breakers on ESSENTIAL BUS, AVIONICS BUS 1 and AVIONICS BUS 2 are capable of being opened, or disengaged from the electrical system, by pulling straight out on the outer ring for emergency electrical load management. Using a circuit breaker as a switch is discouraged since the practice will decrease the life of the circuit breaker. All circuit breakers on ELECTRICAL BUS 1, ELECTRICAL BUS 2 and CROSSFEED BUS are not capable of being opened or disengaged.

The power distribution module uses three push-to-reset circuit breakers for the electrical bus feeders. A fast blow automotive type fuse is used at the standby battery. The standby battery current shunt circuit uses two field replaceable fuses located on the standby battery controller printed circuit board.

Most Garmin G1000 equipment has internal non-field replaceable fuses. Equipment must be returned to Garmin by an approved service station for replacement.

(Continued Next Page)

## **ELECTRICAL SYSTEM** (Continued) **EXTERNAL POWER RECEPTACLE**

A external power receptacle is integral to the power distribution module and allows the use of an external power source for cold weather starting or for lengthy maintenance work on electrical and avionics equipment. The receptacle is located on the left side of the cowl near the firewall. Access to the receptacle is gained by opening the receptacle door.

### **NOTE**

Set the AVIONICS switches BUS 1 and BUS 2 to OFF if no avionics are required. If maintenance on the avionics equipment is required, a 28 VDC regulated and filtered external power source must be provided to prevent damage to the avionics equipment from transient voltages. Set AVIONICS switches BUS 1 and BUS 2 to OFF before starting the engine.

The following check should be made whenever the engine has been started using external power (after disconnecting the external power source).

1. MASTER Switch (ALT and BAT) - OFF
2. Taxi and Landing Lights
  - For Airplanes Equipped With HID Landing/Taxi Lights**
  - a. TAXI and LAND Light Switches - ON
  - For Airplanes Equipped With LED Landing/Taxi Lights**
  - a. LAND Switch - ON
3. Throttle Control - REDUCE TO IDLE
4. MASTER Switch (ALT and BAT) - ON (with taxi and landing lights turned on)
5. Throttle Control - INCREASE (to approximately 1500 RPM)
6. Main Battery (M BATT) Ammeter - CHECK (Battery charging, Amps Positive)
7. LOW VOLTS Annunciator - CHECK (Verify annunciator is not shown)

### **WARNING**

**IF M BATT AMMETER DOES NOT SHOW POSITIVE CHARGE (+ AMPS), OR LOW VOLTS ANNUNCIATOR DOES NOT GO OFF, REMOVE THE BATTERY FROM THE AIRPLANE AND SERVICE OR REPLACE THE BATTERY BEFORE FLIGHT.**

## LIGHTING SYSTEMS

### EXTERIOR LIGHTING

Exterior lighting consists of navigation lights on the wing tips and the tip of the rudder, landing/taxi lights located on the left wing leading edge, or landing/recognition/taxi lights on left and right wing leading edges if LED lights are installed, a flashing beacon mounted on top of the vertical stabilizer, and a strobe light on each wing tip.

Two courtesy lights are recessed into the lower surfaces of each wing and provide illumination for each cabin door area. The switch for the courtesy lights is found on the pilot's overhead console. The rear dome light and under-wing courtesy lights share the same control switch. Pressing the rear dome light switch will make the lights come on and pressing it again will make the lights go out.

All other exterior lights are operated by switches found on the lighted switch panel to the left of the PFD. Exterior lights are grouped together in the LIGHTS section of the switch panel. To activate the BEACON, LAND (landing light), TAXI (taxi light), NAV, and STROBE light(s), place the switch in the up position. Circuit breakers for the lights are found on the lighted circuit breaker panel on the lower left instrument panel, below the PFD. Circuit breakers are grouped by electrical bus with BEACON and LAND on ELECTRICAL BUS 1 and TAXI or RECOG/TAXI (if installed), NAV and STROBE on ELECTRICAL BUS 2.

LED Landing/Taxi/Recognition lights (if installed) use a three position switch labeled LAND, RECOG/TAXI, OFF. Placing the switch in the LAND (landing lights) (up) position activates all LEDs on the left and right wing leading edge lights and is used during takeoffs and landings as required. Placing the switch in the RECOG/TAXI (Recognition/Taxi lights) (center) position with the airplane on the ground, activates the 6 center LEDs which are covered with a spreader lens in each light. When the airplane is in flight, these 6 center LEDs in each light pulse alternately to provide the recognition mode. Recognition mode should be used during day or night flights to enhance visibility to other airplanes. Since LEDs operate at lower temperatures and have longer service life, there are no concerns that would limit the operational time of these lights either on the ground or in flight.

(Continued Next Page)

## LIGHTING SYSTEMS (Continued)

### EXTERIOR LIGHTING (Continued)

#### NOTE

The strobes, flashing beacon and recognition lights (if installed) should not be used when flying through clouds or overcast; the flashing light reflected from water droplets or particles in the atmosphere, particularly at night, can produce vertigo and loss of orientation.

### INTERIOR LIGHTING

Interior lighting is controlled by a combination of dimmable crew area flood lighting, internally lit switch and circuit breaker panels, avionics panel lighting, standby instrument lighting, pedestal lighting, pilot control wheel map lighting and passenger area flood lighting.

Flood lighting is accomplished using two dimmable lights in the front crew area and one dome light in the rear passenger area. These lights are contained in the overhead console, and are controlled by dimmer controls for the front flood lights, and an on-off type push button switch for the rear dome light. The front flood lights can be rotated to provide directional lighting for the pilot and front passenger. The rear dome light provides for general illumination in the rear cabin area. Rear dome light and courtesy lights, located under the wing, share the same control switch.

Lighting of the switch panel, circuit breaker panel, engine controls and environmental control panel is accomplished by using internally lit LED panels. Rotating the SW/CB PANELS dimmer, found on the switch panel in the DIMMING group, controls the lighting level for both panels. Rotating the dimmer counterclockwise decreases light intensity from the highest level to off.

Pedestal lighting consists of a LED strip light incorporated into the Throttle/Flap Control Lever panel located on the bottom of the center instrument panel and a second LED strip light incorporated into the pedestal directly above the 12 volt cabin power outlet. Rotating the PEDESTAL light dimmer, found on the switch panel in the DIMMING group, controls the pedestal lights. Rotating the dimmer counterclockwise decreases light intensity from the highest level to off.

(Continued Next Page)

## **LIGHTING SYSTEMS** (Continued)

### **INTERIOR LIGHTING** (Continued)

Avionics panel lighting consists of the PFD and MFD bezel and display lighting and audio panel lighting. Rotating the AVIONICS dimmer, found on the switch panel in the DIMMING group, controls the lighting level. Positioning the dimmer control in the off position, by rotating the control knob fully counterclockwise causes the avionics displays to use internal photocells to automatically control the lighting levels. This is the recommended use of the avionics lighting for all day and lower lighting levels where lighting of the avionics bezels and keys is not required. In low to night lighting levels rotating the AVIONICS dimmer control clockwise from the off position places all avionics lighting level control to the AVIONICS dimmer control. This is the recommended use of avionics lighting for night and low lighting conditions to allow the pilot control of the avionics illumination levels as dark adaptation occurs.

Rotating the STBY IND dimmer control, found on the switch panel in the DIMMING group, controls lighting of the standby airspeed indicator, attitude indicator, altimeter and non-stabilized magnetic compass. If the standby flight instrument (GI 275) is installed, it controls the lighting level of the display and non-stabilized magnetic compass. Rotating the dimmer control knob counterclockwise decreases light intensity from the highest level to the minimum level or off. In the minimum level or off position, if the external dimming input fails, or is below the minimum input level, the standby flight instrument automatically controls internal dimming of the display by photocell.

Pilot's chart (map) lighting is accomplished by use of a rheostat and a light assembly, both found on the lower surface of the pilot's control wheel. The light provides downward illumination from the bottom of the control wheel to the pilot's lap area. To operate the light, first turn the NAV light switch ON, and then adjust the map light intensity using the knurled rheostat knob. Rotating the dimmer clockwise (when facing up) increases light intensity, and rotating the dimmer counterclockwise decreases light intensity.

(Continued Next Page)

## **LIGHTING SYSTEMS** (Continued)

### **INTERIOR LIGHTING** (Continued)

Regardless of the light system in question, the most probable cause of a light failure is a burned out bulb. However, in the event any lighting systems fails to come on, check the appropriate circuit breaker. For interior lighting failure check the PANEL LTS circuit breaker, and for exterior lighting failure check the associated light function circuit breaker (i.e. landing light, LAND LT circuit breaker). If the circuit breaker has opened, and there is no obvious indication of a short circuit (smoke or odor), turn the affected lights OFF, reset the circuit breaker, and turn the lights ON again. If the circuit breaker opens again, do not reset until maintenance has been performed.

## **CABIN HEATING, VENTILATING AND DEFROSTING SYSTEM**

The temperature and volume of airflow into the cabin can be regulated by manipulation of the push-pull CABIN HT and CABIN AIR control knobs, Refer to Figure 7-8. Both control knobs are the double button locking-type and permit intermediate control settings.

For cabin ventilation, pull the CABIN AIR control knob full out. To raise the air temperature, pull the CABIN HT control knob out approximately 1/4 to 1/2 inch for a small amount of cabin heat. Additional heat is available by pulling the CABIN HT control knob out farther; maximum heat is available with the CABIN HT control knob pulled full out and the CABIN AIR control knob pushed full in. When no heat is desired in the cabin, the CABIN HT control knob is pushed full in.

Front cabin heat and ventilating air is supplied by outlet holes spaced across a cabin manifold just forward of the pilot's and front passenger's feet. Rear cabin heat and air is supplied by two ducts from the manifold, one extending down each side of the cabin to an outlet just aft of the rudder pedals at floor level. Windshield defrost air is also supplied by two ducts leading from the cabin manifold to defroster outlets near the lower edge of the windshield. Two knobs control sliding valves in either defroster outlet to permit regulation of defroster airflow.

Separate adjustable ventilators supply additional air; one near each upper corner of the windshield supplies air for the pilot and front passenger, and two ventilators are available for the rear cabin area to supply air to the rear seat passengers. There are additional ventilators located in various positions in the cockpit.

**CABIN HEATING, VENTILATION AND DEFROSTING SYSTEM**

B3116

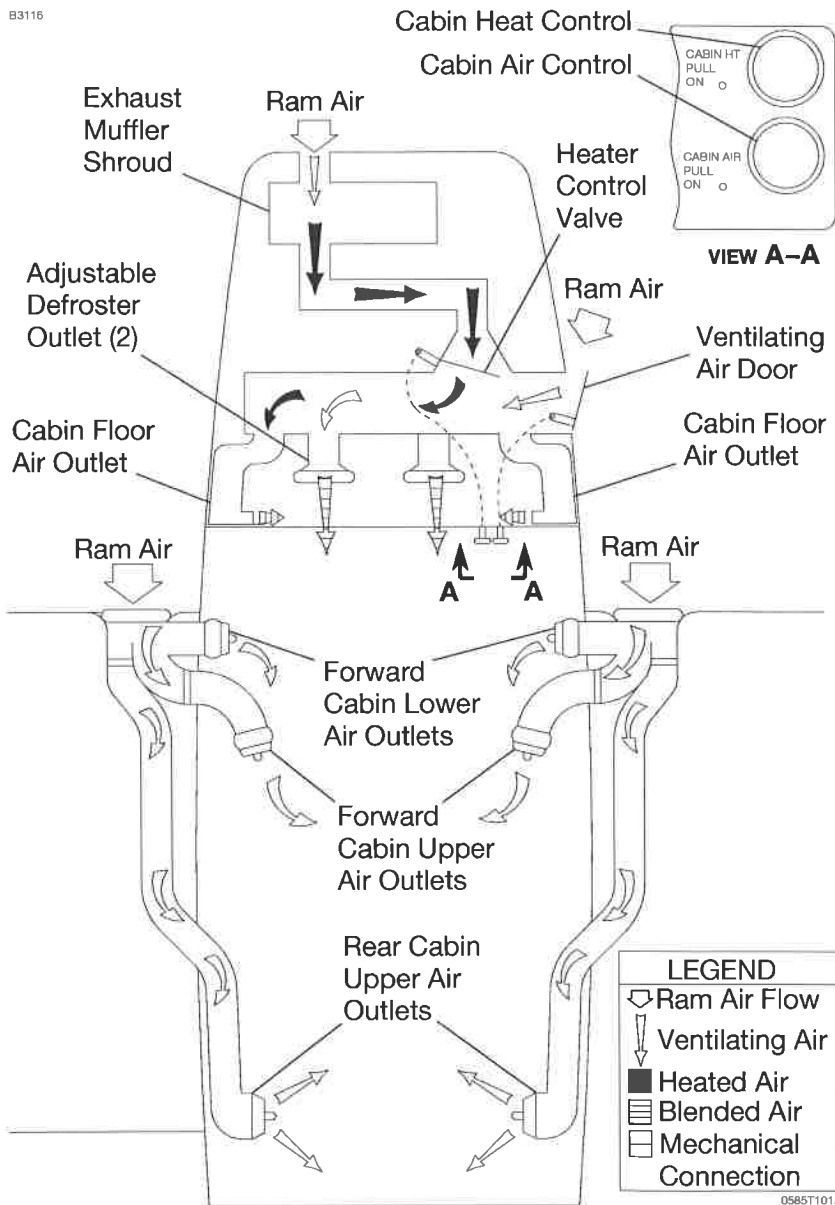

0585T1015

Figure 7-8

## PITOT-STATIC SYSTEM AND INSTRUMENTS

The pitot-static system uses a heated total pressure (pitot) head mounted on the lower surface of the left wing, external static port mounted on the left side of the forward fuselage and associated plumbing to connect the air data computer and the conventional pitot-static instruments to the sources.

The heated pitot system uses an electrical heating element built in the body of the pitot head. The PITOT HEAT control switch is found on the switch panel below the lower left corner of the PFD. The PITOT HEAT circuit breaker is found on the circuit breaker panel at the lower left side of the pilot panel.

A static pressure alternate source valve (ALT STATIC AIR) is located adjacent to the throttle control. The ALT STATIC AIR valve provides static pressure from inside the cabin if the external static pressure source becomes blocked.

If erroneous instrument readings are suspected due to water or ice in the pressure line going to the standard external static pressure source, the alternate static source valve should be pulled on.

Pressures within the cabin will vary with open heaters/vents and windows. Refer to Section 5, Figure 5-1 (Sheet 2), for the Airspeed Calibration, Alternate Static Source correction chart.

## **VACUUM SYSTEM AND INSTRUMENTS** (if installed)

The vacuum system, Refer to Figure 7-9, provides the vacuum necessary to operate the standby attitude indicator. The system consists of one engine-driven vacuum pump, a vacuum regulator, the standby attitude indicator, a vacuum system air filter, and a vacuum transducer. The vacuum transducer provides a signal to the engine display that is processed and displayed as vacuum on the EIS ENGINE page. If available vacuum, from the engine-driven vacuum pump, drops below 3.5 in.hg., the LOW VACUUM annunciator will display in amber on the PFD.

### **ATTITUDE INDICATOR**

The standby attitude indicator is a vacuum-powered gyroscopic instrument, found on the center instrument panel below the MFD. The attitude indicator includes a low-vacuum warning flag (GYRO) that comes into view when the vacuum is below the level necessary for reliable gyroscope operation.

### **VACUUM INDICATOR**

The vacuum indicator is incorporated on the EIS ENGINE page, found along the left side of the PFD during engine start or the left edge of the MFD during normal operation. During reversionary operation, the EIS bar appears along the left side of the operational display.

### **LOW VACUUM ANNUNCIATION**

A low vacuum condition is annunciated along the right side of the PFD by a amber LOW VACUUM annunciator.

**VACUUM SYSTEM** (if installed)

B4016

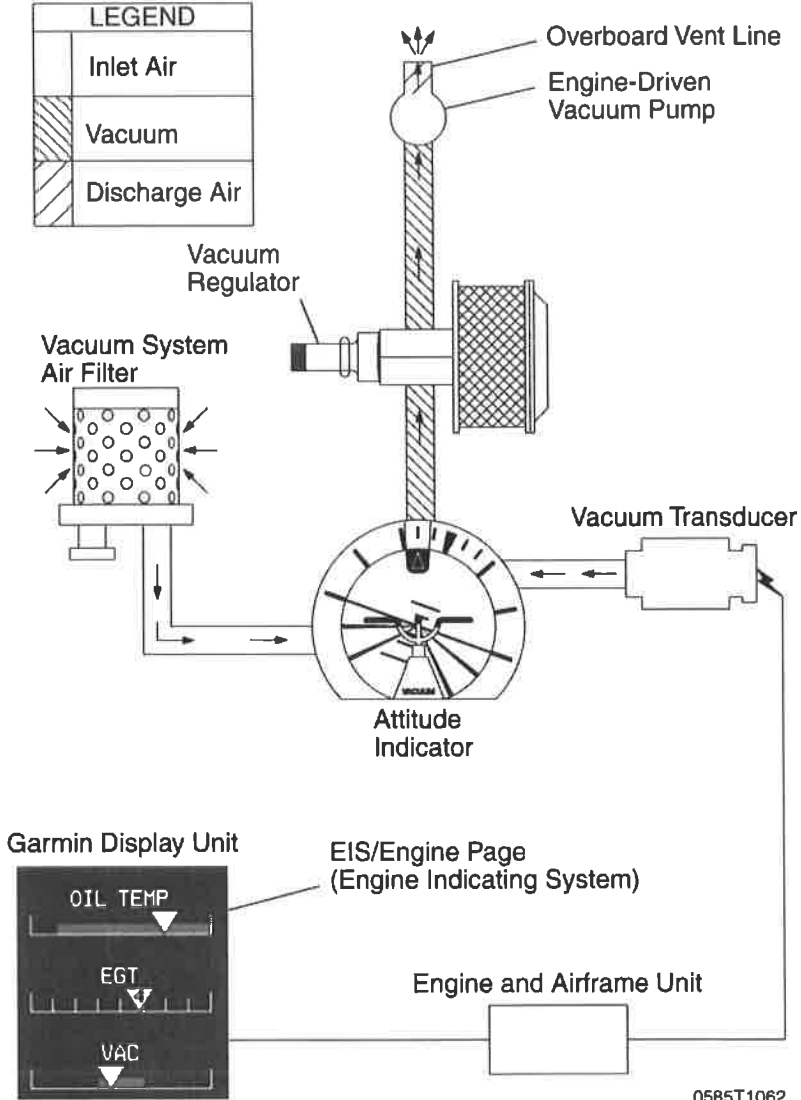

0585T1062

Figure 7-9

## **CLOCK/O.A.T. INDICATOR**

A numerical time or clock window, based on GPS time, and an outside air temperature (O.A.T.) indicator window are provided along the lower edge of the PFD. The O.A.T. indicator uses an air temperature sensor located on top of the cabin.

## **STALL WARNING SYSTEM**

The airplane is equipped with a pneumatic-type stall warning system consisting of an inlet in the leading edge of the left wing, an air-operated horn near the upper left corner of the windshield, and associated plumbing. As the airplane approaches a stall, the low pressure on the upper surface of the wings moves forward around the leading edge of the wings. This low pressure creates a differential pressure in the stall warning system which draws air through the warning horn, resulting in a audible warning at 5 to 10 knots above stall in all flight conditions.

The stall warning system should be checked during the preflight inspection by applying suction to the system either by placing a clean handkerchief over the vent opening and applying suction or using some other type of suction device to activate the warning horn. The system is operational if the warning horn sounds when suction is applied.

## **STANDARD AVIONICS**

The Garmin G1000 Avionics System is an integrated flight control and navigation system. The system combines primary flight instruments, communications, airplane system information and navigational information all displayed on two color displays. The G1000 system consists of the following pieces of equipment:

### **GARMIN DISPLAY UNITS (GDU)**

Two identical units are mounted on the instrument panel. One, located in front of the pilot, is configured as a PFD. A second panel, located to the right, is configured as a MFD.

The PFD displays roll and pitch information, heading and course navigation information, plus altitude, airspeed and vertical speed information to the pilot. The PFD also controls and displays all communication and navigation frequencies as well as displaying warning/status annunciations of airplane systems.

The MFD displays a large scalable, moving map that corresponds to the airplane's current location. Data from other components of the system can be overlaid on this map. Location and direction of movement of nearby aircraft, lightning and weather information can all be displayed on the MFD. The MFD is also the principle display for all of the engine, fuel, and electrical system parameters.

The reversionary mode places the flight information and basic engine information on both the PFD and the MFD. This feature allows the pilot full access to all necessary information should either of the display screens malfunction.

(Continued Next Page)

## **STANDARD AVIONICS** (Continued)

### **AUDIO PANEL (GMA)**

The audio panel for the G1000 system integrates all of the communication and navigation digital audio signals, intercom system and marker beacon controls in one unit. It is installed on the instrument panel between the PFD and the MFD. The audio panel also controls the reversionary mode for the PFD and MFD.

#### **NOTE**

Use of the COM 1/2 function is not approved.

### **INTEGRATED AVIONICS UNIT (GIA)**

Two integrated avionics units are installed in the G1000 system. They are mounted in racks in the tailcone. These units act as the main communications hub linking all of the other peripheral parts to the GDU displays. Each unit contains a GPS receiver, a VHF navigation receiver, VHF communication transceiver and the main system microprocessors. The first GIA unit to acquire a GPS satellite 3-D navigation signal is the active GPS source.

### **ATTITUDE AND HEADING REFERENCE SYSTEM (AHRS) AND MAGNETOMETER (GRS)**

The AHRS provides airplane attitude and flight characteristics information to the G1000 displays and to the integrated avionics units, which is located in the tailcone. The AHRS unit contains accelerometers, tilt sensors and rate sensors that replace spinning mass gyros used in other airplanes. The magnetometer is located inside the left wing panel and interfaces with the AHRS to provide heading information.

(Continued Next Page)

## **STANDARD AVIONICS** (Continued)

### **AIR DATA COMPUTER (GDC)**

The Air Data Computer (ADC) compiles information from the airplane's pitot-static system. The ADC unit is mounted in the tailcone. An outside air temperature probe, mounted on top of the cabin, is connected to the ADC. The ADC calculates pressure altitude, airspeed, true airspeed, vertical speed and outside air temperature.

### **ENGINE MONITOR (GEA)**

The Engine Monitor is responsible for receiving and processing the signals from all of the engine and airframe sensors. It is connected to all of the CHT measuring sensors, EGT sensors, RPM, fuel flow and to the fuel gauging system. This unit transmits this information to the engine display computers.

### **TRANSPONDER (GTX)**

The full-featured Mode S transponder provides Mode A, C and S functions. Control and operation of the transponder is accomplished using the PFD. The transponder unit is mounted in the tailcone avionics racks.

### **XM WEATHER AND RADIO DATA LINK (GDL)**

The XM weather and radio data link provides weather information and digital audio entertainment in the cockpit. The unit is mounted in the tailcone. This unit communicates with the MFD on the high-speed data bus. XM weather and XM radio operate in the S-band frequency range to provide continuous uplink capabilities at any altitude throughout North America. A subscription to the XM satellite radio service is required for the XM weather and radio data link to be used.

(Continued Next Page)

## **STANDARD AVIONICS (Continued)**

### **GFC 700 AUTOMATIC FLIGHT CONTROL SYSTEM (AFCS)** (if installed)

Refer to the Garmin G1000 CRG for more information on system operation.

### **CONTROL WHEEL STEERING (CWS)**

The Control Wheel Steering (CWS) button, located on the pilot's control wheel, immediately disconnects the pitch and roll servos when activated. Large pitch changes while using CWS will cause the airplane to be out of trim. Retrim the airplane as necessary during CWS operation to reduce control forces or large pitch oscillations that may occur after releasing the CWS button.

#### **WARNING**

**WHEN THE AUTOPILOT IS ENGAGED IN NAV, APR OR BC OPERATING MODES, IF THE HSI NAVIGATION SOURCE IS CHANGED MANUALLY, USING THE CDI SOFTKEY OR SBAS IS UNAVAILABLE DURING A LP APPROACH (PRIOR TO FAF), THE NAVIGATION SIGNAL TO THE AUTOPILOT WILL BE INTERRUPTED AND CAUSE THE AUTOPILOT TO REVERT TO ROL MODE OPERATION. NO AURAL ALERT WILL BE PROVIDED. IN ROL MODE, THE AUTOPILOT WILL ONLY KEEP THE WINGS LEVEL AND WILL NOT CORRECT THE AIRPLANE HEADING OR COURSE. SET THE HDG BUG TO THE CORRECT HEADING AND VERIFY/SELECT THE CORRECT NAVIGATION SOURCE ON THE HSI BEFORE ENGAGING THE AUTOPILOT IN ANY OTHER OPERATING MODE.**

(Continued Next Page)

### GFC 700 SYSTEM SCHEMATIC

B8019

G1000 PFD AP/FD Modes and Annunciator G1000 MFD

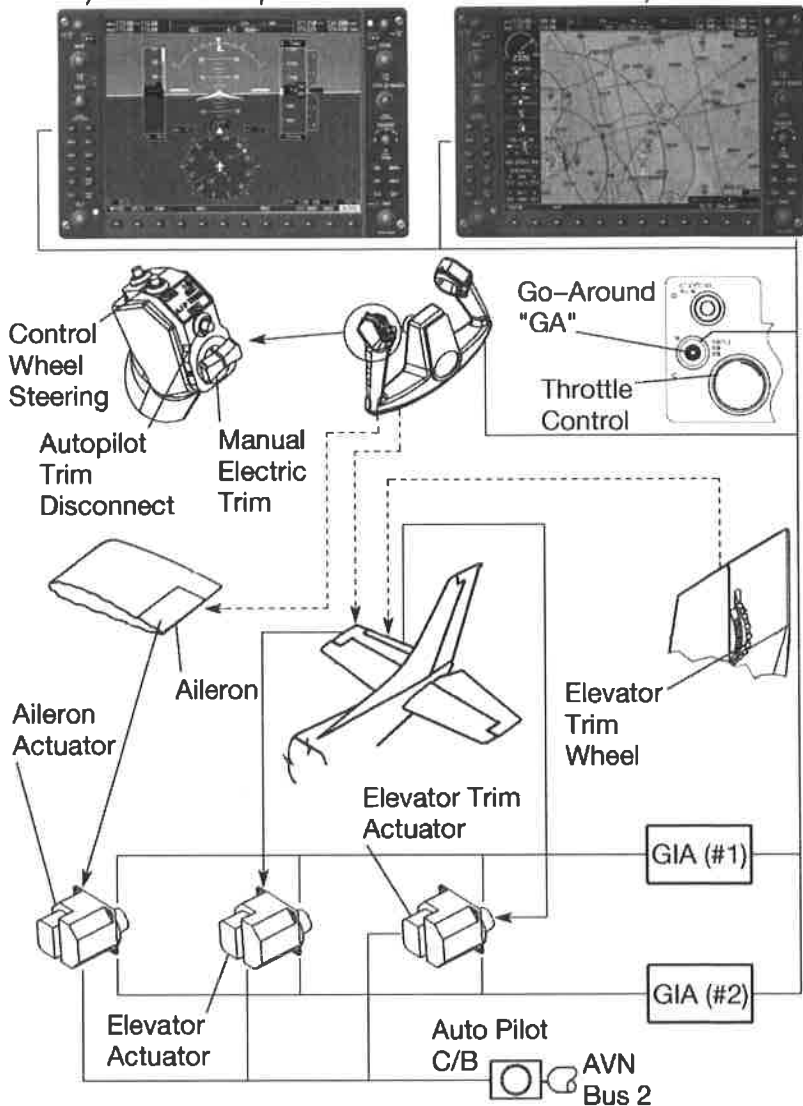

Figure 7-10

## **AVIONICS SUPPORT EQUIPMENT**

Avionics cooling fans, antennas, microphone and headset provisions, power converter and static discharge wicks support the operation of the avionics equipment installations.

### **AVIONICS COOLING FANS**

Four DC electric fans provide forced air and ambient air circulation cooling for the G1000 avionics equipment. A single fan in the tailcone provides forced air cooling to the integrated avionics units and to the transponder. A fan located forward of the instrument panel removes air from between the firewall bulkhead and instrument panel, directing the warm air up at the inside of the windshield. Two additional fans blow air directly onto the heat sinks located on the forward sides of the PFD and MFD.

Power is provided to these fans when the MASTER (BAT) switch and the AVIONICS (BUS 1 and BUS 2) switch are all ON.

#### **NOTE**

None of the cooling fans will operate when the essential bus avionics equipment is being powered by the standby battery.

(Continued Next Page)

## AVIONICS SUPPORT EQUIPMENT (Continued)

### ANTENNAS

Two dual-mode VHF COM/GPS antennas are mounted on the top of the cabin. The COM 1/GPS 1 antenna is mounted on the right side and the COM 2/GPS 2 antenna is mounted on the left side. They are connected to the two VHF communication transceivers and the two GPS receivers in the integrated avionics units.

The GDL antenna is also mounted on the top of the cabin. It provides a signal to the GDL-69A XM Data Link receiver.

A blade-type navigation antenna is mounted on either side of the vertical stabilizer. This antenna provides VOR and glideslope signals to the VHF navigation receivers contained in the integrated avionics units.

The marker beacon antenna is mounted on the bottom of the tailcone. It provides the signal to the marker beacon receiver located in the audio panel.

The transponder antenna is mounted on the bottom of the cabin and is connected to the Mode S transponder by a coaxial transmission cable.

The Bendix/King Distance Measuring Equipment (DME) antenna (if installed) is mounted on the bottom of the tailcone and is connected to the Bendix/King DME receiver by a coaxial cable.

(Continued Next Page)

## **AVIONICS SUPPORT EQUIPMENT** (Continued)

### **MICROPHONE AND HEADSET INSTALLATIONS**

Standard equipment for the airplane includes a hand-held microphone, an overhead speaker, two remote-keyed microphone switches on the control wheels, and provisions for communications headsets at each pilot and passenger station.

The hand-held microphone includes an integral push-to-talk switch. This microphone is plugged in at the center pedestal and is accessible to both the pilot and front passenger. Pressing the push-to-talk switch allows voice transmission on the COM radios.

The overhead speaker is located in the center overhead console. Volume and output for this speaker are controlled through the audio panel.

Each control wheel contains a push-to-talk switch. This switch allows the pilot or front passenger to transmit on the COM radios using remote microphones.

Each seat position of the airplane has provisions for aviation-style headsets. Microphone and headphone jacks are located on each respective sidewall panel for communications between passengers and pilot. The system is designed so that microphones are voice activated. Only the pilot or front passenger can transmit through the COM radios.

#### **NOTE**

To ensure audibility and clarity when transmitting with the hand-held microphone, always hold it as closely as possible to the lips, then press the transmit switch and speak directly into it. Avoid covering the opening on the back side of microphone for optimum noise canceling.

(Continued Next Page)

## **AVIONICS SUPPORT EQUIPMENT** (Continued)

### **AUXILIARY AUDIO INPUT JACK**

An auxiliary audio input jack (AUX AUDIO IN) is located on the center pedestal, Refer to Figure 7-2. It allows entertainment audio devices such as cassette, compact disc, and MP3 players to play music over the airplane's headsets.

The signal from AUX AUDIO IN is automatically muted during radio communications or pilot selection of crew intercom isolation modes located on the audio panel. The AUX key on the audio panel does not control the AUX AUDIO IN signal. For a more complete description and operating instructions of the audio panel, refer to the Garmin G1000 CRG.

Since the entertainment audio input is not controlled by a switch, there is no way to deselect the entertainment source except to disconnect the source at the audio input connector. In the event of a high pilot workload and/or heavy traffic, it is wise to disable the entertainment audio to eliminate a source of distraction for the flight crew.

#### **NOTE**

- Passenger briefing should specify that AUX AUDIO IN (entertainment audio input) and Portable Electronic Device (PED) use is permitted only during the enroute phase of flight.
- Disconnect the cable from the AUX AUDIO IN jack when not in use.
- Use caution with audio cables in the cabin to avoid entangling occupants or cabin furnishings and to prevent damage to cables.

(Continued Next Page)

## **AVIONICS SUPPORT EQUIPMENT** (Continued)

### **12V POWER OUTLET** (if installed)

A power converter, located on the cabin side of the firewall just forward of the right instrument panel, reduces the airplane's 28 VDC power to 12 VDC. This converter provides up to 10 amps of power to operate portable devices such as notebook computers and audio players. The power output connector (POWER OUTLET 12V -10A) is located on the center pedestal, Refer to Figure 7-2.

A switch located on the switch panel labeled CABIN PWR 12V controls the operation of the power outlet.

#### **CAUTION**

- CHARGING OF LITHIUM BATTERIES MAY CAUSE THE LITHIUM BATTERIES TO EXPLODE.
- TAKE CARE TO OBSERVE THE MANUFACTURER'S POWER REQUIREMENTS PRIOR TO PLUGGING ANY DEVICE INTO THE 12 VOLT CABIN POWER SYSTEM CONNECTOR. THIS SYSTEM IS LIMITED TO A MAXIMUM OF 10 AMPS.
- USE CAUTION WITH POWER/ADAPTER CABLES IN THE CABIN TO AVOID ENTANGLING OCCUPANTS OR CABIN FURNISHINGS AND TO PREVENT DAMAGE TO CABLES SUPPLYING LIVE ELECTRIC CURRENT.
- DISCONNECT POWER/ADAPTER CABLES WHEN NOT IN USE.

(Continued Next Page)

## **AVIONICS SUPPORT EQUIPMENT** (Continued)

### **STATIC DISCHARGERS**

Static dischargers are installed at various points throughout the airframe to reduce interference from precipitation static. Under some severe static conditions, loss of radio signals is possible even with static dischargers installed. Whenever possible, avoid known severe precipitation areas to prevent loss of dependable radio signals. If avoidance is impractical, minimize airspeed and anticipate temporary loss of radio signals while in these areas.

Static dischargers lose their effectiveness with age, and therefore, should be checked periodically, at least at every annual inspection, by a qualified technician.

## **CABIN FEATURES**

### **EMERGENCY LOCATOR TRANSMITTER (ELT)**

Refer to Section 9, Supplements 1 or 2 for appropriate ELT operating information.

### **CABIN FIRE EXTINGUISHER**

A portable Halon 1211 (Bromochlorodifluoromethane) fire extinguisher is installed in a holder on the floorboard between the front seats to be accessible in case of fire. The extinguisher is classified 5B:C by Underwriters Laboratories.

The extinguisher should be checked prior to each flight to ensure that the pressure of the contents, as indicated by the gage at the top of the extinguisher, is within the green arc (approximately 125 psi) and the operating lever lock pin is securely in place.

To operate the fire extinguisher:

1. Loosen retaining clamp(s) and remove extinguisher from bracket.
2. Hold extinguisher upright, pull operating ring pin, and press lever while directing the liquid at the base of the fire at the near edge. Progress toward the back of the fire by moving the nozzle rapidly with a side-to-side sweeping motion.

### **WARNING**

**VENTILATE THE CABIN PROMPTLY AFTER SUCCESSFULLY EXTINGUISHING THE FIRE TO REDUCE THE GASES PRODUCED BY THERMAL DECOMPOSITION.**

3. The contents of the cabin fire extinguisher will empty in approximately eight seconds of continuous use.

Fire extinguishers should be recharged by a qualified fire extinguisher agency after each use. After recharging, secure the extinguisher to its mounting bracket.

(Continued Next Page)

## **CABIN FEATURES** (Continued)

### **CARBON MONOXIDE DETECTION SYSTEM**

The carbon monoxide (CO) detection system consist of a single detector located behind the instrument panel, powered by the airplane's DC electrical system and integrated in the Garmin G1000 system with a warning annunciation and alert messages displayed on the PFD.

When the CO detection system senses a CO level of 50 parts-per-million (PPM) by volume or greater the alarm turns on a flashing warning annunciation, CO LVL HIGH, in the annunciation window on the PFD with a continuous tone until the PFD softkey below WARNING is pushed. It then remains on steady until the CO level drops below 50 PPM and automatically resets the alarm.

If the CO system detects a problem within the system that requires service, a CO DET SRVC message is displayed in the alerts window of the PFD. If there is an interface problem between the G1000 system and the CO system a CO DET FAIL message is displayed in the alerts window of the PFD.

## AIRPLANE HANDLING, SERVICE AND MAINTENANCE

### TABLE OF CONTENTS

	Page
Introduction . . . . .	8-3
Identification Plate . . . . .	8-4
Cessna Owner Advisories . . . . .	8-4
United States Airplane Owners . . . . .	8-4
International Airplane Owners . . . . .	8-4
Publications . . . . .	8-5
Airplane File . . . . .	8-6
Airplane Inspection Periods . . . . .	8-7
FAA Required Inspections . . . . .	8-7
Cessna Inspection Programs . . . . .	8-7
Cessna Customer Care Program . . . . .	8-8
Pilot Conducted Preventive Maintenance . . . . .	8-8
Alterations Or Repairs . . . . .	8-9
Ground Handling . . . . .	8-9
Towing . . . . .	8-9
Parking . . . . .	8-9
Tiedown . . . . .	8-10
Jacking . . . . .	8-10
Leveling . . . . .	8-11
Flyable Storage . . . . .	8-11
Servicing . . . . .	8-12
Oil . . . . .	8-13
Oil Specification . . . . .	8-13
Recommended Viscosity For Temperature Range . . . . .	8-13
Capacity Of Engine Sump . . . . .	8-14
Oil And Oil Filter Change . . . . .	8-14

(Continued Next Page)

**TABLE OF CONTENTS** (Continued)

	Page
Fuel .....	8-15
Approved Fuel Grades (And Colors) .....	8-15
Fuel Capacity .....	8-15
Fuel Additives .....	8-16
Fuel Contamination .....	8-20
Landing Gear .....	8-21
Cleaning And Care .....	8-22
Windshield And Windows .....	8-22
Painted Surfaces .....	8-23
Propeller Care .....	8-24
Engine Care .....	8-24
Interior Care .....	8-25/8-26
Avionics Care .....	8-25/8-26

## INTRODUCTION

This section contains factory recommended procedures for proper ground handling and routine care and servicing of your airplane. It also identifies certain inspection and maintenance requirements which must be followed if your airplane is to retain that new airplane performance and dependability. It is important to follow a planned schedule of lubrication and preventive maintenance based on climatic and flying conditions encountered in your local area.

Keep in touch with your local Textron Aviation service facility and take advantage of their knowledge and experience. Your Textron Aviation service facility knows your airplane and how to maintain it, and will remind you when lubrications and oil changes are necessary, as well as other seasonal and periodic services.

The airplane should be regularly inspected and maintained in accordance with information found in the airplane maintenance manual and in company issued service bulletins and service newsletters. All service bulletins pertaining to the airplane by serial number should be accomplished and the airplane should receive repetitive and required inspections. The manufacturer does not condone modifications, whether by Supplemental Type Certificate (STC) or otherwise, unless these certificates are held and/or approved by the manufacturer. Other modifications may void warranties on the airplane since Cessna has no way of knowing the full effect on the overall airplane. Operation of an airplane that has been modified may be a risk to the occupants, and operating procedures and performance data set forth in the POH may no longer be considered accurate for the modified airplane.

## IDENTIFICATION PLATE

All correspondence regarding your airplane should include the Serial Number. The Serial Number, Model Number, Production Certificate Number (PC) and Type Certificate Number (TC) can be found on the Identification Plate, located on the aft left tailcone. The Finish and Trim Plate, which is installed on the lower part of the left forward doorpost, contains a code describing the exterior paint combination of the airplane. The code may be used in conjunction with an applicable Illustrated Parts Catalog if finish and trim information is needed.

## CESSNA OWNER ADVISORIES

Cessna Owner Advisories are sent to Cessna Aircraft FAA Registered owners of record at no charge to inform them about mandatory and/or beneficial airplane service requirements and product changes. Copies of the actual bulletins are available from Textron Aviation service facilities and Textron Aviation Customer Service.

## UNITED STATES AIRPLANE OWNERS

If your airplane is registered in the U.S., appropriate Cessna Owner Advisories will be mailed to you automatically according to the latest airplane registration name and address which you have provided to the FAA. Therefore, it is important that you provide correct and up to date mailing information to the FAA.

If you require a duplicate Owner Advisory to be sent to an address different from the FAA aircraft registration address, please complete and return an Owner Advisory Application (otherwise no action is required on your part).

## INTERNATIONAL AIRPLANE OWNERS

To receive Cessna Owner Advisories, please complete and return an Owner Advisory Application.

Receipt of a valid Owner Advisory Application will establish your Cessna Owner Advisory service for one year, after which you will be sent a renewal notice. It is important that you respond promptly to update your address for this critical service.

## PUBLICATIONS

Various publications and flight operation aids are furnished in the airplane when delivered from the factory. These items are listed below.

- Customer Care Program Handbook
- Pilot's Operating Handbook and FAA Approved Airplane Flight Manual
- Pilot's Checklist
- Passenger Briefing Card

Utilizing your local authorized Textron Aviation service facility is always recommended. To locate the closest facility to you, please visit: [txtav.com/en/service-locator](http://txtav.com/en/service-locator).

To obtain owner advisory information or replacement publications, please contact the Textron Aviation Technical Manual Distribution Center at (316) 517-6215 or email [TMDC@txtav.com](mailto:TMDC@txtav.com). Additional aircraft and publication subscription information may be found at the following website: [ww2.txtav.com/technicalpublications](http://ww2.txtav.com/technicalpublications).

## AIRPLANE FILE

There are miscellaneous data, information and licenses that are a part of the airplane file. The following is a checklist for that file. In addition, a periodic check should be made of the latest Federal Aviation Regulations to ensure that all data requirements are met.

To be displayed in the airplane at all times:

1. Aircraft Airworthiness Certificate (FAA Form 8100-2)
2. Aircraft Registration Certificate (FAA Form 8050-3)
3. Aircraft Radio Station License, (if applicable)

To be carried in the airplane at all times:

1. Current Pilot's Operating Handbook and FAA Approved Airplane Flight Manual
2. Garmin G1000 Cockpit Reference Guide (190-00384-00 Rev. B or subsequent)
3. Weight and Balance, and associated papers (latest copy of the Repair and Alteration Form, FAA Form 337, if applicable)
4. Equipment List

To be made available upon request:

1. Airplane Logbook
2. Engine Logbook

Most of the items listed are required by the United States Federal Aviation Regulations. Since the regulations of other nations may require other documents and data, owners of airplanes not registered in the United States should check with their own aviation officials to determine their individual requirements.

Cessna recommends that these items, plus the Pilot's Checklists, Customer Care Program Handbook and Customer Care Card, be carried in the airplane at all times.

## **AIRPLANE INSPECTION PERIODS**

### **FAA REQUIRED INSPECTIONS**

As required by U.S. Federal Aviation Regulations, all civil aircraft of U.S. registry must undergo a complete inspection (annual) each twelve calendar months. In addition to the required annual inspection, aircraft operated commercially (for hire) must have a complete inspection every 100 hours of operation.

The FAA may require other inspections by the issuance of airworthiness directives applicable to the airplane, engine, propeller and components. It is the responsibility of the owner/operator to ensure compliance with all applicable airworthiness directives, and when the inspections are repetitive, to take appropriate steps to prevent inadvertent noncompliance.

### **CESSNA INSPECTION PROGRAMS**

In lieu of the 100 hour and annual inspection requirements, an airplane may be inspected in accordance with a Progressive Care Inspection Program or a PhaseCard Inspection Program. Both programs offer systems which allow the work load to be divided into smaller operations that can be accomplished in shorter time periods.

The Cessna Progressive Care Inspection Program allows an airplane to be inspected and maintained in four operations. The four operations are recycled each 200 hours and are recorded in a specially provided Aircraft Inspection Log as each operation is conducted.

The PhaseCard Inspection Program offers a parallel system for high-utilization flight operations (approximately 600 flight hours per year). This system utilizes 50 hour intervals (Phase 1 and Phase 2) to inspect high-usage systems and components. At 12 months or 600 flight hours, whichever occurs first, the airplane undergoes a complete (Phase 3) inspection.

Regardless of the inspection method selected, the owner should keep in mind that 14 CFR 43 and 14 CFR 91 establishes the requirement that properly certified agencies or personnel accomplish all required FAA inspections and most of the manufacturer recommended inspections.

(Continued Next Page)

## **AIRPLANE INSPECTION PERIODS** (Continued)

### **CESSNA CUSTOMER CARE PROGRAM**

Specific benefits and provisions of the Cessna Warranty plus other important benefits for you are contained in your Customer Care Program Handbook supplied with your airplane. The Customer Care Program Handbook should be thoroughly reviewed and kept in the airplane at all times.

You will also want to return to your Cessna Service Station either at 50 hours for your first Progressive Care Operation, or at 100 hours for your first 100 hour inspection depending on which program you choose to establish for your airplane. While these important inspections will be performed for you by any Cessna Service Station, in most cases you will prefer to have the Cessna Service Station from whom you purchased the airplane accomplish this work.

### **PILOT CONDUCTED PREVENTIVE MAINTENANCE**

A certified pilot who owns or operates an airplane not used as an air carrier is authorized by 14 CFR 43 to perform limited maintenance on his airplane. Refer to 14 CFR 43 for a list of the specific maintenance operations which are allowed.

#### **NOTE**

Pilots operating airplanes of other than U.S. registry should refer to the regulations of the country of certification for information on preventive maintenance that may be performed by pilots.

A Maintenance Manual must be obtained prior to performing any preventive maintenance to ensure that proper procedures are followed. A Cessna Service Station should be contacted for further information or for required maintenance which must be accomplished by appropriately licensed personnel.

## **ALTERATIONS OR REPAIRS**

It is essential that the FAA be contacted prior to any alterations on the airplane to ensure that airworthiness of the airplane is not violated. Alterations or repairs to the airplane must be accomplished by licensed personnel, utilizing only FAA Approved components and FAA Approved data, such as Cessna Service Bulletins.

## **GROUND HANDLING**

### **TOWING**

The airplane is most easily and safely maneuvered by hand with the tow bar attached to the nosewheel (the tow bar is stowed on the side of the baggage area). When towing with a vehicle, do not exceed the nose gear turning angle of 30° either side of center, or damage to the nose landing gear will result.

### **CAUTION**

**REMOVE ANY INSTALLED RUDDER LOCK BEFORE TOWING.**

If the airplane is towed or pushed over a rough surface during hangaring, watch that the normal cushioning action of the nose strut does not cause excessive vertical movement of the tail and the resulting contact with low hangar doors or structure. A flat nose tire or deflated strut will also increase tail height.

### **PARKING**

When parking the airplane, head into the wind and set the parking brake. Do not set the parking brake during cold weather when accumulated moisture may freeze the brakes, or when the brakes are overheated. Install the control wheel lock and chock the wheels. In severe weather and high wind conditions, tie the airplane down as outlined in the following paragraph.

(Continued Next Page)

## **GROUND HANDLING** (Continued)

### **TIEDOWN**

Proper tiedown procedure is the best precaution against damage to the parked airplane by gusty or strong winds. To tiedown the airplane securely, proceed as follows:

1. Set the parking brake and install the control wheel lock.
2. Install a surface control lock over the fin and rudder.
3. Tie sufficiently strong ropes or chains (700 pounds tensile strength) to the wing, tail and nose tiedown fittings and secure each rope or chain to a ramp tiedown.
4. Install a pitot tube cover.

### **JACKING**

When a requirement exists to jack the entire airplane off the ground, or when wing jack points are used in the jacking operation, refer to the Maintenance Manual for specific procedures and equipment required.

Individual main gear may be jacked by using the jack pad which is incorporated in the main landing gear strut step bracket. When using the individual gear strut jack pad, flexibility of the gear strut will cause the main wheel to slide inboard as the wheel is raised, tilting the jack. The jack must then be lowered for a second jacking operation. Do not jack both main wheels simultaneously using the individual main gear jack pads.

### **CAUTION**

**DO NOT APPLY PRESSURE ON THE ELEVATOR OR HORIZONTAL STABILIZER SURFACES. WHEN PUSHING ON THE TAILCONE, ALWAYS APPLY PRESSURE AT A BULKHEAD TO AVOID BUCKLING THE SKIN.**

If nose gear maintenance is required, the nosewheel may be raised off the ground by pressing down on a tailcone bulkhead, just forward of the horizontal stabilizer, and allowing the tail to rest on the tail tiedown ring.

(Continued Next Page)

## **GROUND HANDLING** (Continued)

### **JACKING** (Continued)

To assist in raising and holding the nosewheel off the ground, ground anchors should be utilized at the tail tiedown point.

#### **NOTE**

Ensure that the nose will be held off the ground under all conditions by means of suitable stands or supports under weight supporting bulkheads near the nose of the airplane.

### **LEVELING**

Longitudinal leveling of the airplane is accomplished by placing a level on leveling screws located on the left side of the tailcone. Deflate the nose tire and/or lower or raise the nose strut to properly center the bubble in the level. Corresponding points on both upper door sills may be used to level the airplane laterally.

### **FLYABLE STORAGE**

Engines in airplanes that are flown every 30 days or less may not achieve normal service life because of internal corrosion. Corrosion occurs when moisture from the air and the products of combustion combine to attack cylinder walls and bearing surfaces during periods when the airplane is not flown.

The minimum recommended operating frequency for the engine is one continuous flight hour (not counting taxi, takeoff and landing time) with oil temperatures of 165°F to 200°F every 30 days or less (depending on location and storage conditions). Airplanes operated close to oceans, lakes, rivers and in humid regions are in greater need of engine preservation than airplanes operated in arid regions. Appropriate engine preservation procedures must be practiced by the owner or operator of the airplane based on present environmental conditions and the frequency of airplane activity.

#### **NOTE**

The engine manufacturer does not recommend pulling the engine through by hand during storage periods.

(Continued Next Page)

## **GROUND HANDLING** (Continued)

### **FLYABLE STORAGE** (Continued)

If the airplane is to remain inactive for more than 30 days, consult the latest revision of Textron Lycoming Service Letter L180 ([www.lycoming.textron.com](http://www.lycoming.textron.com)).

It is recommended when storing the airplane for any period of time to keep fuel tanks full to minimize condensation in tanks. Keep the battery fully charged to prevent the electrolyte from freezing in cold weather. Refer to the Maintenance Manual for proper airplane storage procedures.

## **SERVICING**

In addition to the Preflight Inspection covered in Section 4 of this POH, complete servicing, inspection and test requirements for your airplane are detailed in the Maintenance Manual. The Maintenance Manual outlines all items which require attention at specific intervals plus those items which require servicing, inspection, and/or testing at special intervals.

Since Cessna Service Stations conduct all service, inspection, and test procedures in accordance with applicable Maintenance Manuals, it is recommended that you contact a Cessna Service Station concerning these requirements and begin scheduling your airplane for service at the recommended intervals.

Cessna Progressive Care ensures that these requirements are accomplished at the required intervals to comply with the 100 hour or annual inspection as previously covered.

Depending on various flight operations, your local government aviation agency may require additional service, inspections, or tests. For these regulatory requirements, owners should check with local aviation officials where the airplane is being operated.

For quick and ready reference, quantities, materials and specifications for frequently used service items are as follows.

## OIL

### OIL SPECIFICATION

MIL-L-6082 or SAE J1966 Aviation Grade Straight Mineral Oil: Used when the airplane was delivered from the factory and should be used to replenish the supply during the first 25 hours. This oil should be drained and the filter changed after the first 25 hours of operation. Refill the engine with MIL-L-6082 or SAE J1966 Aviation Grade Straight Mineral Oil and continue to use until a total of 50 hours has accumulated or oil consumption has stabilized.

MIL-L-22851 or SAE J1899 Aviation Grade Ashless Dispersant Oil: Oil conforming to Textron Lycoming Service Instruction No 1014, and all revisions and supplements thereto, **must be used** after first 50 hours or oil consumption has stabilized.

### RECOMMENDED VISCOSITY FOR TEMPERATURE RANGE

Multiviscosity or straight grade oil may be used throughout the year for engine lubrication. Refer to the following table for temperature versus viscosity ranges.

Temperature	MIL-L-6082 or SAE J1966 Straight Mineral Oil SAE Grade	MIL-L-22851 or SAE J1899 Ashless Dispersant Oil SAE Grade
Above 27°C (80°F)	60	60
Above 16°C (60°F)	50	40 or 50
-1°C (30°F) to 32°C (90°F)	40	40
-18°C (0°F) to 21°C (70°F)	30	30, 40 or 20W-40
Below -12°C (10°F)	20	30 or 20W-30
-18°C (0°F) to 32°C (90°F)	20W-50	20W-50 or 15W-50
All Temperatures	---	15W-50 or 20W-50

#### NOTE

When operating temperatures overlap, use the lighter grade of oil.

(Continued Next Page)

## **OIL** (Continued)

### **CAPACITY OF ENGINE SUMP**

The engine has a total capacity of 9 quarts, with the oil filter accounting for approximately 1 quart of that total. The engine oil sump has a capacity of 8 quarts. The engine must not be operated on less than 5 quarts (as measured by the dipstick). For extended flights, the engine should be filled to capacity.

### **OIL AND OIL FILTER CHANGE**

After the first 25 hours of operation, drain the engine oil sump and replace the filter. Refill sump with straight mineral oil and use until a total of 50 hours has accumulated or oil consumption has stabilized; then change to ashless dispersant oil. Ashless dispersant oil (and oil filter) should be changed at time intervals set forth by the engine manufacturer.

#### **NOTE**

During the first 25 hour oil and filter change, a general inspection of the overall engine compartment is required. Items which are not normally checked during a preflight inspection should be given special attention. Hoses, metal lines and fittings should be inspected for signs of oil and fuel leaks, and checked for abrasions, chafing, security, proper routing and support, and evidence of deterioration. Inspect the intake and exhaust systems for cracks, evidence of leakage, and security of attachment. Engine controls and linkages should be checked for freedom of movement through their full range, security of attachment and evidence of wear. Inspect wiring for security, chafing, burning, defective insulation, loose or broken terminals, heat deterioration, and corroded terminals. Check the alternator belt in accordance with Maintenance Manual instructions, and retighten if necessary. A periodic check of these items during subsequent servicing operations is recommended.

## FUEL

### APPROVED FUEL GRADES (AND COLORS)

- 100LL Grade Aviation Fuel (Blue)
- 100 Grade Aviation Fuel (Green)

#### NOTE

Isopropyl alcohol or Diethylene Glycol Monomethyl Ether (DiEGME) may be added to the fuel supply in quantities not to exceed 1% (alcohol) or 0.15% (DiEGME) of total volume. Refer to Fuel Additives in later paragraphs for additional information.

### FUEL CAPACITY

56.0 U.S. Gallons Total: ..... 28.0 U.S. Gallons per tank.

#### NOTE

- To ensure maximum fuel capacity when refueling and minimize crossfeeding, the fuel selector valve should be placed in either the LEFT or RIGHT position and the airplane parked in a wings level, normal ground attitude. Refer to Figure 1-1 for a definition of normal ground attitude.
- Service the fuel system after each flight, and keep fuel tanks full to minimize condensation in the tanks.

(Continued Next Page)

## **FUEL** (Continued)

### **FUEL ADDITIVES**

Strict adherence to recommended preflight draining instructions as called for in Section 4 will eliminate any free water accumulations from the tank sumps. While small amounts of water may still remain in solution in the gasoline, it will normally be consumed and go unnoticed in the operation of the engine.

One exception to this can be encountered when operating under the combined effect of: (1) use of certain fuels, with (2) high humidity conditions on the ground (3) followed by flight at high altitude and low temperature. Under these unusual conditions, small amounts of water in solution can precipitate from the fuel stream and freeze in sufficient quantities to induce partial icing of the engine fuel system.

While these conditions are quite rare and will not normally pose a problem to owners and operators, they do exist in certain areas of the world and consequently must be dealt with, when encountered.

Therefore, to help alleviate the possibility of fuel icing occurring under these unusual conditions, it is permissible to add isopropyl alcohol or Diethylene Glycol Monomethyl Ether (DiEGME) compound to the fuel supply.

The introduction of alcohol or DiEGME compound into the fuel provides two distinct effects: (1) it absorbs the dissolved water from the gasoline and (2) alcohol has a freezing temperature depressant effect.

#### **NOTE**

When using fuel additives, it must be remembered that the final goal is to obtain a correct fuel to additive ratio in the tank, and not just with fuel coming out of the refueling nozzle. For example, adding 15 gallons of correctly proportioned fuel to a tank which contains 20 gallons of untreated fuel will result in a lower than acceptable concentration level to the 35 gallons of fuel which now reside in the tank.

(Continued Next Page)

## **FUEL** (Continued)

### **FUEL ADDITIVES** (Continued)

Alcohol, if used, is to be blended with the fuel in a concentration of 1% by volume. Concentrations greater than 1% are not recommended since they can be detrimental to fuel tank materials.

The manner in which the alcohol is added to the fuel is significant because alcohol is most effective when it is completely dissolved in the fuel. To ensure proper mixing, the following is recommended:

1. For best results, the alcohol should be added during the fueling operation by pouring the alcohol directly on the fuel stream issuing from the fueling nozzle.
2. An alternate method that may be used is to premix the complete alcohol dosage with some fuel in a separate clean container (approximately 2-3 gallon capacity) and then transferring this mixture to the tank prior to the fuel operation.

(Continued Next Page)

### FUEL MIXING RATIO

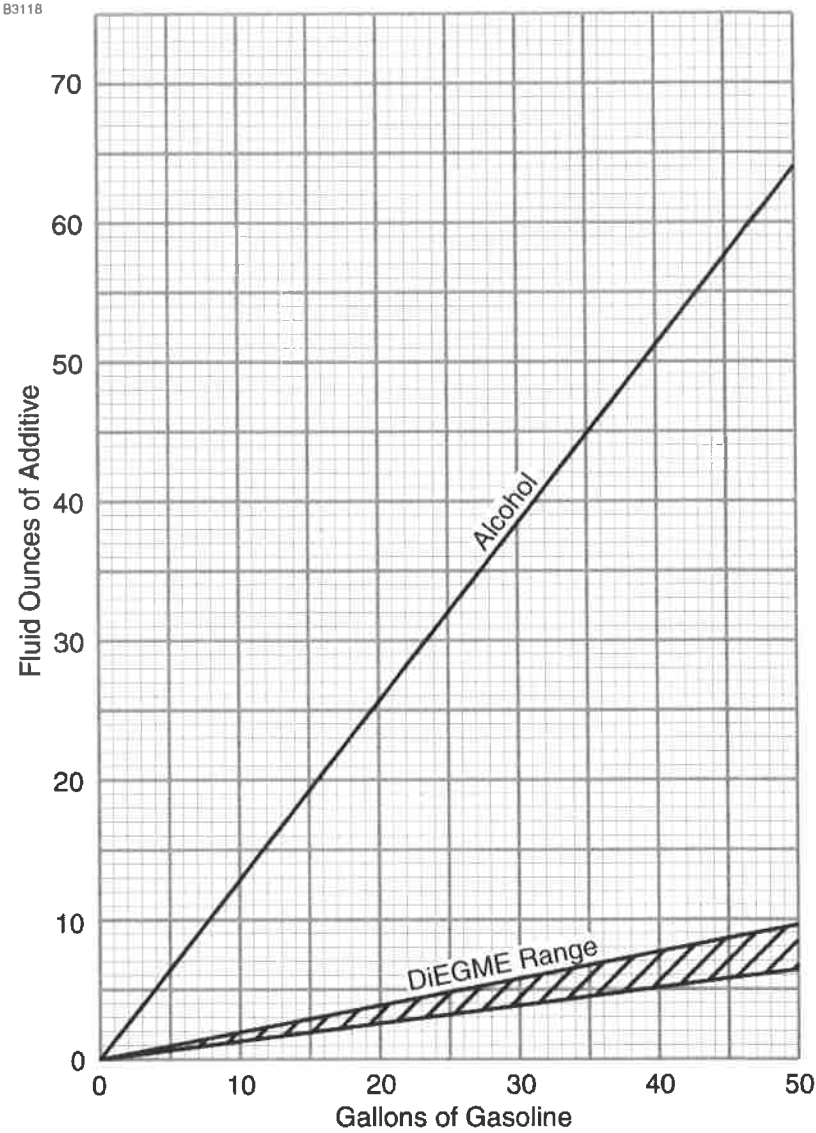

Figure 8-1

## **FUEL** (Continued)

### **FUEL ADDITIVES** (Continued)

Diethylene Glycol Monomethyl Ether (DiEGME) compound must be carefully mixed with the fuel in concentrations between 0.10% (minimum) and 0.15% (maximum) of total fuel volume. Refer to Figure 8-1 for a DiEGME-to-fuel mixing chart.

#### **WARNING**

**ANTI-ICING ADDITIVE IS DANGEROUS TO HEALTH WHEN BREATHED AND/OR ABSORBED INTO THE SKIN.**

#### **CAUTION**

MIXING OF DIEGME WITH FUEL IS EXTREMELY IMPORTANT. A CONCENTRATION IN EXCESS OF THAT RECOMMENDED (0.15% BY VOLUME MAXIMUM) MAY RESULT IN DETRIMENTAL EFFECTS TO THE FUEL TANK AND SEALANT, AND DAMAGE TO O-RINGS AND SEALS USED IN THE FUEL SYSTEM AND ENGINE COMPONENTS. A CONCENTRATION OF LESS THAN THAT RECOMMENDED (0.10% BY TOTAL VOLUME MINIMUM) WILL RESULT IN INEFFECTIVE TREATMENT. USE ONLY BLENDING EQUIPMENT THAT IS RECOMMENDED BY THE MANUFACTURER TO OBTAIN PROPER PROPORTIONING.

Prolonged storage of the airplane will result in a water buildup in the fuel which leeches out the additive. An indication of this is when an excessive amount of water accumulates in the fuel tank sumps. The concentration can be checked using a differential refractometer. It is imperative that the technical manual for the differential refractometer be followed explicitly when checking the additive concentration.

(Continued Next Page)

## FUEL (Continued)

### FUEL CONTAMINATION

Fuel contamination is usually the result of foreign material present in the fuel system, and may consist of water, rust, sand, dirt, microbes or bacterial growth. In addition, additives that are not compatible with fuel or fuel system components can cause the fuel to become contaminated.

Before each flight and after each refueling, use a clear sampler cup and drain at least a cupful of fuel from each fuel tank drain location and from the fuel strainer quick drain valve to determine if contaminants are present, and to ensure the airplane has been fueled with the proper grade of fuel.

If contamination is detected, drain **all** fuel drain points again, including the fuel reservoir tank and fuel selector drain valves, and then gently rock the wings and lower the tail to the ground to move any additional contaminants to the sampling points. Take repeated samples from all fuel drain points until **all** contamination has been removed. If, after repeated sampling, evidence of contamination still exists, the airplane should not be flown. Tanks should be drained and system purged by qualified maintenance personnel. All evidence of contamination must be removed before further flight. If the airplane has been serviced with the improper fuel grade, defuel completely and refuel with the correct grade. Do not fly the airplane with contaminated or unapproved fuel.

In addition, Owners/Operators who are not acquainted with a particular fixed base operator should be assured that the fuel supply has been checked for contamination and is properly filtered before allowing the airplane to be serviced. Fuel tanks should be kept full between flights, provided weight and balance considerations will permit, to reduce the possibility of water condensing on the walls of partially filled tanks.

To further reduce the possibility of contaminated fuel, routine maintenance of the fuel system should be performed in accordance with the airplane Maintenance Manual. Only the proper fuel, as recommended in this POH, should be used, and fuel additives should not be used unless approved by Cessna and the Federal Aviation Administration.

## LANDING GEAR

Consult the following table for servicing information on the landing gear.

COMPONENT	SERVICING CRITERIA
Nose Wheel (5.00-5, 6-Ply Rated Tire)	45.0 PSI
Main Wheel (6.00-6, 6-Ply Rated Tire)	42.0 PSI
Brakes	MIL-H-5606
Nose Gear Shock Strut	MIL-H-5606; 45.0 PSI *

\* Keep strut filled with MIL-H-5606 hydraulic fluid per filling instructions placard, and with no load on the strut, inflate with air to 45.0 PSI. Do not over inflate.

## **CLEANING AND CARE**

### **WINDSHIELD AND WINDOWS**

The plastic windshield and windows should be cleaned with an airplane windshield cleaner. Apply the cleaner sparingly with soft cloths, and rub with moderate pressure until all dirt, oil scum and bug stains are removed. Allow the cleaner to dry, then wipe it off with soft flannel cloths.

#### **CAUTION**

**NEVER USE GASOLINE, BENZENE, ALCOHOL, ACETONE, FIRE EXTINGUISHER, ANTI-ICE FLUID, LACQUER THINNER OR GLASS CLEANER TO CLEAN THE PLASTIC. THESE MATERIALS WILL ATTACK THE PLASTIC AND MAY CAUSE IT TO CRAZE.**

If a windshield cleaner is not available, the plastic can be cleaned with soft cloths moistened with Stoddard solvent to remove oil and grease. Follow by carefully washing with a mild detergent and plenty of water. Rinse thoroughly, then dry with a clean moist chamois.

Do not rub the plastic with a dry cloth since this builds up an electrostatic charge which attracts dust. Waxing with a good commercial wax will finish the cleaning job. A thin, even coat of wax, polished out by hand with clean soft flannel cloths, will fill in minor scratches and help prevent further scratching.

Do not use a canvas cover on the windshield unless freezing rain or sleet is anticipated since the cover may scratch the plastic surface.

(Continued Next Page)

## **CLEANING AND CARE** (Continued)

### **PAINTED SURFACES**

The painted exterior surfaces of your new Cessna have a durable, long lasting finish.

Generally, the painted surfaces can be kept bright by washing with water and mild soap, followed by a rinse with water and drying with cloths or a chamois. Harsh or abrasive soaps or detergents which cause corrosion or scratches should never be used. Remove stubborn oil and grease with a cloth moistened with Stoddard solvent. Take special care to make sure that the exterior graphics are not touched by the solvent. For complete care of exterior graphics, refer to the Maintenance Manual.

To seal any minor surface chips or scratches and protect against corrosion, the airplane should be waxed regularly with a good automotive wax applied in accordance with the manufacturer's instructions. If the airplane is operated in a seacoast or other salt water environment, it must be washed and waxed more frequently to assure adequate protection. Special care should be taken to seal around rivet heads and skin laps, which are the areas most susceptible to corrosion. A heavier coating of wax on the leading edges of the wings and tail and on the cowl nose cap and propeller spinner will help reduce the abrasion encountered in these areas. Reapplication of wax will generally be necessary after cleaning with soap solution or after chemical deicing operations.

When the airplane is parked outside in cold climates and it is necessary to remove ice before flight, care should be taken to protect the painted surfaces during ice removal with chemical liquids. Isopropyl alcohol will satisfactorily remove ice accumulations without damaging the paint. However, keep the isopropyl alcohol away from the windshield and cabin windows since it will attack the plastic and may cause it to craze.

(Continued Next Page)

## **CLEANING AND CARE** (Continued)

### **PROPELLER CARE**

Preflight inspection of propeller blades for nicks, and wiping them occasionally with an oily cloth to clean off grass and bug stains will assure long blade life. Small nicks on the propeller, particularly near the tips and on the leading edges, should be dressed out as soon as possible since these nicks produce stress concentrations, and if ignored, may result in cracks or failure of the propeller blade. Never use an alkaline cleaner on the blades; remove grease and dirt with Stoddard solvent.

### **ENGINE CARE**

The engine may be cleaned, using a suitable solvent, in accordance with instructions in the Maintenance Manual. Most efficient cleaning is done using a spray type cleaner. Before spray cleaning, ensure that protection is afforded for components which might be adversely affected by the solvent. Refer to the airplane Maintenance Manual for proper lubrication of controls and components after engine cleaning. The induction air filter should be replaced when its condition warrants, not to exceed 500 hours.

(Continued Next Page)

## **CLEANING AND CARE** (Continued)

### **INTERIOR CARE**

To remove dust and loose dirt from the upholstery and carpet, clean the interior regularly with a vacuum cleaner.

Blot up any spilled liquid promptly with cleansing tissue or rags. Do not pat the spot; press the blotting material firmly and hold it for several seconds. Continue blotting until no more liquid is taken up. Scrape off sticky materials with a dull knife, then spot clean the area.

Oily spots may be cleaned with household spot removers, used sparingly. Before using any solvent, read the instructions on the container and test it on an obscure place on the fabric to be cleaned. Never saturate the fabric with a volatile solvent; it may damage the padding and backing materials.

Soiled upholstery and carpet may be cleaned with foam type detergent, used according to the manufacturer's instructions. To minimize wetting the fabric, keep the foam as dry as possible and remove it with a vacuum cleaner.

For complete information related to interior cleaning, refer to the Maintenance Manual.

### **AVIONICS CARE**

The Garmin GDU displays have an anti-reflective coating that is very sensitive to skin oils, waxes, ammonia, and abrasive cleaners. Clean the displays as described in the G1000 Cockpit Reference Guide.



## SUPPLEMENTS

### INTRODUCTION

The supplements in this section contain amended operating limitations, operating procedures, performance data and other necessary information for airplanes conducting special operations for both standard and optional equipment installed in the airplane. Operators should refer to each supplement to ensure that all limitations and procedures appropriate for their airplane are observed.

A non FAA Approved Log Of Approved Supplements is provided for convenience only. This log is a numerical list of all FAA Approved supplements applicable to this airplane by name, supplement number and revision level. This log should be used as a checklist to ensure all applicable supplements have been placed in the Pilot's Operating Handbook (POH). Supplements for both standard and installed optional equipment must be maintained to the latest revision. Those supplements applicable to optional equipment which is not installed in the airplane, do not have to be retained.

Each individual supplement contains its own Log of Effective Pages. This log lists the page number and revision level of every page in the supplement. The log also lists the dates on which revisions to the supplement occurred. Supplement page numbers will include an S and the supplement number preceding the page number.

The part number of the supplement provides information on the revision level. Refer to the following example:

172SPHBUS -S1 -00

Revision Level of Supplement

Supplement Number

Cessna 172S, Nav III GFC 700 AFCS,  
U.S. Pilot's Operating Handbook (Serials  
172S10468, 172S10507, 172S10640 and  
172S10656 and On)



## LOG OF APPROVED SUPPLEMENTS

### NOTE

It is the airplane owner's responsibility to make sure that he or she has the latest revision to each supplement of a Pilot's Operating Handbook, and the latest issued "Log Of Approved Supplements". This "Log Of Approved Supplements" was the latest version as of the date it was shipped by the manufacturer; however, some changes may have occurred, and the owner should verify this is the latest, most up-to-date version by contacting the Technical Manual Distribution Center at (316) 517-5800.

Supplement Number	Name	Revision Level	Equipment Installed
1	Artex ME406 Emergency Locator Transmitter (ELT)	0	X
2	Artex C406-N Emergency Locator Transmitter (ELT)	0	_____
3	Bendix/King KR87 Automatic Direction Finder (ADF)	0	_____
4	Winterization Kit	0	_____
5	JAR-OPS Operational Eligibility	0	_____
6	Canadian Certified Airplanes	1	_____
7	Brazilian Certified Airplanes	4	_____
8	Argentine Certified Airplanes	1	_____
9	Observer Seat Kit	0	_____
10	Japanese Registered Airplanes	0	_____
11	Garmin G1000 Synthetic Vision Technology (SVT)	1	_____
12	Garmin GTS 800 Traffic Advisory System (TAS)	0	_____
13	Russian Federation (RF) and Other Commonwealth of Independent States (CIS) Countries	0	_____
14	Right Switch and Circuit Breaker Panel	0	_____

(Continued Next Page)

**LOG OF APPROVED SUPPLEMENTS** (Continued)

Supplement Number	Name	Revision Level	Equipment Installed
15	Max-Viz EVS-600 Enhanced Vision System	0	
16	Ukrainian Certified Airplanes	0	_____
17	Hot Weather Operations	0	_____
18	Reserved		_____
19	Safe Flight SCc AoA System	0	_____
20	ARTEX ELT1000 Emergency Locator Transmitter (ELT)	0	_____

## TABLE OF CONTENTS

### SECTION 9

#### ADDITIONAL STC SUPPLEMENTS

NUMBER	NAME	REVISION NUMBER	SUPPLEMENT NUMBER	EQUIPMENT INSTALLED
3	<i>Bendix/King DME KN63</i>	00	<i>ASR-2008-011- OMA-05a.1-00</i>	X
4	<i>Bendix/King ADF KR87</i>	00	<i>ASR-2008-011- OMA-05a.2-00</i>	X
5	<i>Charterware OBU Flight Logger</i>	01	<i>CS23var-010715- 01-ASM-01</i>	X





# Pilot's Operating Handbook And FAA Approved Airplane Flight Manual SKYHAWK SP

## CESSNA MODEL 172S

### NAV III AVIONICS OPTION - GFC 700 AFCS

Serials 172S10648, 172S10507, 172S10640  
and 172S10656 and On

### SUPPLEMENT 1

### ARTEX ME406

### EMERGENCY LOCATOR TRANSMITTER (ELT)

SERIAL NO.	172S10773
REGISTRATION NO.	OE-DCL

This supplement must be inserted into Section 9 of the Pilot's Operating Handbook and FAA Approved Airplane Flight Manual when the Artex ME406 Emergency Locator Transmitter (ELT) is installed.

**APPROVED BY**

FAA APPROVED UNDER 14 CFR PART 21 SUBPART J  
Cessna Aircraft Co.  
Delegation Option Authorization DCA-852064-CE

*RLS*  
Administrative AR



Member of GAMA

**DATE OF APPROVAL** 20 December 2007

**20 DECEMBER 2007**

COPYRIGHT © 2007  
CESSNA AIRCRAFT COMPANY  
WICHITA, KANSAS, USA

172SPHBUS-S1-00

U.S.

S-1-1

## SUPPLEMENT 1

### ARTEX ME406 EMERGENCY LOCATOR TRANSMITTER (ELT)

Use the Log of Effective Pages to determine the current status of this supplement.

Pages affected by the current revision are indicated by an asterisk (\*) preceding the page number.

<u>Supplement Status</u>	<u>Date</u>
Original Issue	20 December 2007

### LOG OF EFFECTIVE PAGES

---

Page Number	Page Status	Revision Number
S1-1 thru S1-8	Original	0

AmSafe, Inc.  
Inflatable Restraints Division  
1043 N. 47<sup>th</sup> Avenue  
Phoenix, AZ, 85043  
Document No.: E508810  
Revision: D

**FAA APPROVED**  
**AIRPLANE FLIGHT MANUAL SUPPLEMENT**  
to  
**PILOT'S OPERATING HANDBOOK AND**  
**FAA APPROVED AIRPLANE FLIGHT MANUAL**  
for  
**Cessna Aircraft Company**  
**Skyhawk Models: 172R, 172S**  
**Skylane Models 182S, 182T, T182T**  
**Stationair Models 206H, T206H**

**OE-DCL**  
**Airplane Reg. No. \_\_\_\_\_ Airplane S/N: 172S10773**

This supplement must be attached to the FAA-Approved Cessna Airplane Models 172R, 172S, 182S, 182T, T182T, 206H, and T206H associated Pilot's Operating Handbook and FAA Approved Airplane Flight Manual when the Airplane is modified by the installation of AmSafe Aviation Inflatable Restraint (AAIR<sup>®</sup>) System, V23 Version in accordance with STC No. SA01700LA.

The information contained herein supplements or supersedes the basic manual only in those areas listed herein. For limitations, procedures, and performance information not contained in this supplement, consult the associated Pilot's Operating Handbook and FAA Approved Airplane Flight Manual.

**FAA APPROVED**   
**Manager, Flight Test Branch, ANM-160L**  
**Federal Aviation Administration**  
**Los Angeles Aircraft Certification Office**  
**Transport Airplane Directorate**

Date June 28, 2007

**LOG OF REVISIONS**

REV	NO	EFFECTED PAGES	DATE	DESCRIPTION	FAA APPROVAL
JR		Title (1)	11-24-04	Initial Release	<u>Original signed P. Power</u> Manager, Flight Test Branch, ANM-160L Federal Aviation Administration Los Angeles Aircraft Certification Office Transport Airplane Directorate  Date: <u>November 24, 2004</u>
		Log Page (2)	11-24-04		
		3	11-24-04		
		4	11-24-04		
A		Log Page (2)	12-21-04	Added information in SECTION 1 and a limitation in SECTION 2, Corrected Moment Arm for system installations in all models.	<u>Original signed by P. Power</u> Manager, Flight Test Branch, ANM-160L Federal Aviation Administration Los Angeles Aircraft Certification Office Transport Airplane Directorate  Date: <u>December 21, 2004</u>
		3	12-21-04		
		4	12-21-04		
B		Log Page (2)	4-14-05	Added weight and balance information summary for Models 172, 182, and 206 without rear bench seat AAIR Systems.	<u>Original signed by P. Power</u> Manager, Flight Test Branch, ANM-160L Federal Aviation Administration Los Angeles Aircraft Certification Office Transport Airplane Directorate  Date: <u>April 14, 2005</u>
		4	4-14-05		
C		Log Page (2)	10-26-05	Section 6 – changed paragraph to explain alternate calculation concerning new EMA.  Added weight and balance information summary for Model 206 additional kits and added alternate summaries for all models with new, lighter EMA in parenthesis.	<u>Original signed by P. Power</u> Manager, Flight Test Branch, ANM-160L Federal Aviation Administration Los Angeles Aircraft Certification Office Transport Airplane Directorate  Date: <u>October 26, 2005</u>
		4	10-26-05		
		5 - Added	10-26-05		
D		Title (1)	6-28-07	Updated Title by removing POH part numbers and added Title and page to footer.  Section 2 – First paragraph – deleted part numbers from first sentence and deleted reference to part numbers above in last sentence. Third paragraph – sentence was "The restraint in an empty co-pilot or passenger seat must not ..." Added warning label for orientation of airbag and information on additional Child Seat Buckle for Middle Seats of 206.  Section 6 – deleted bolded empty weight in all summaries and deleted last paragraph.  Whole Document – updated changed Company name from AMSAFE, Inc. to AmSafe, Inc. Unless proper name, aircraft was replaced with airplane.	<u>[Signature]</u> Manager, Flight Test Branch, ANM-160L Federal Aviation Administration Los Angeles Aircraft Certification Office Transport Airplane Directorate  Date: <u>June 28, 2007</u>
		Log Page (2)	6-28-07		
		3	6-28-07		
		4	6-28-07		
		5	6-28-07		
		5	6-28-07		

**SECTION 1 GENERAL**

The AAIR V23 is a self-contained, modular, three-point restraint system that improves protection from serious head-impact injury during a survivable airplane crash by inclusion of an inflatable airbag to the lapbelt portion of the three-point restraint. An unbuckled restraint airbag will not inflate.

**SECTION 2 LIMITATIONS**

A child safety seat shall not be used with the V23 AAIR System in the front seat (co-pilot). A child safety seat may be used in the rear seat positions only by attaching the child seat with an auxiliary child seat buckle. The standard inflatable restraint buckle cannot be used to secure a child safety seat.

The Auxiliary Child Seat Buckle adapter secures a Child Safety Seat to either left or right positions of the Rear Seat for all models and the Middle Seats for Model 206 (see warning label below). For the Rear Seats, it is typically stored under the cushion and is found in the center of the seat adjacent to the standard AAIR End-Release Buckle Assembly. For the Middle Seats of Model 206, it is attached at the same attachment point as the metal strap AAIR End-release Buckle Assy and may be stored under the seat cushion. Both these Child Seat Buckle adapters are identifiable by part number below and attach to the Airbag Belt portion of the Seatbelt Airbag Assembly (see diagram).

It is recommended that the restraint in an empty co-pilot or passenger seat not be buckled to prevent inflation of the lapbelt airbag in the unoccupied seat.



Representative Seatbelt Warning Label  
 Note: Label side of belt goes towards occupant.

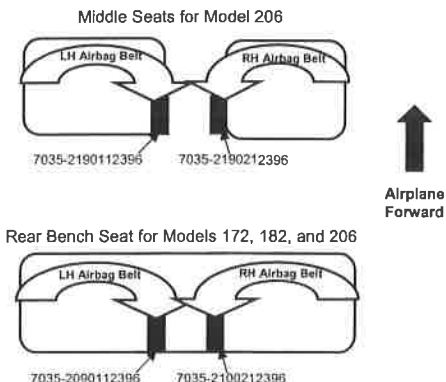

### SECTION 3 EMERGENCY PROCEDURES

No Change

### SECTION 4 NORMAL PROCEDURES

To activate the system, join (buckle) the three-point restraint in the same manner as any other three-point seatbelt. An empty co-pilot or passenger seat restraint must not be buckled.

### SECTION 5 PERFORMANCE

No Change

### SECTION 6 WEIGHT AND BALANCE/EQUIPMENT LIST

For complete information of the AAIR V23 System effect on weight and balance loading to the airplane, please refer to AmSafe Aviation's, Weight and Balance Information Report, Document No. E508952.

In the summary that follows, Empty Weights and Moments are given for AAIR Systems with the current EMA, P/N 508358-409 and the new, lighter-weight EMA, P/N 508358-421, useful for loading and Center of Gravity calculations. Those expressed in parentheses were calculated using the new, lighter EMA, P/N 508358-421.

#### Models 172R, 172S – with optional rear seat bench AAIR System

<u>Weight-lbs.</u>	<u>Arm-in.</u>	<u>Moment-in. lbs.</u>	
7.638	57.928	442.454	AAIR System Difference Added (EMA, P/N 508358-409)
(7.338)		(425.075)	AAIR System Difference Added (EMA, P/N 508358-421)

#### Models 172R, 172S – without optional rear seat bench AAIR System

<u>Weight-lbs.</u>	<u>Arm-in.</u>	<u>Moment-in. lbs.</u>	
3.848	45.397	174.686	AAIR System Difference Added (EMA, P/N 508358-409)
(3.698)		(167.871)	AAIR System Difference Added (EMA, P/N 508358-421)

#### Models 182S, 182T, T182T – with rear seat bench AAIR System

<u>Weight-lbs.</u>	<u>Arm-in.</u>	<u>Moment-in. lbs.</u>	
7.638	57.682	440.578	AAIR System Difference Added (EMA, P/N 508358-409)
(7.338)		(423.270)	AAIR System Difference Added (EMA, P/N 508358-421)

#### Models 182S, 182T, T182T – without rear seat bench AAIR System

<u>Weight-lbs.</u>	<u>Arm-in.</u>	<u>Moment-in. lbs.</u>	
3.848	41.798	160.838	AAIR System Difference Added (EMA, P/N 508358-409)
(3.698)		(154.569)	AAIR System Difference Added (EMA, P/N 508358-421)

#### Models 206H, T206H – with optional rear seat bench AAIR System

<u>Weight-lbs.</u>	<u>Arm-in.</u>	<u>Moment-in. lbs.</u>	
11.54	69.782	805.284	AAIR System Difference Added (EMA, P/N 508358-409)
(11.090)		(773.882)	AAIR System Difference Added (EMA, P/N 508358-421)

#### Models 206H, T206H – without optional rear seat bench AAIR System

<u>Weight-lbs.</u>	<u>Arm-in.</u>	<u>Moment-in. lbs.</u>	
7.75	53.852	417.350	AAIR System Difference Added (EMA, P/N 508358-409)
(7.450)		(401.197)	AAIR System Difference Added (EMA, P/N 508358-421)

AmSafe, Inc.  
Inflatable Restraints Division  
1043 N. 47<sup>th</sup> Avenue  
Phoenix, AZ, 85043  
Document No.: E508810  
Revision: D

AFM Supplement for  
AmSafe Aviation Inflatable Restraint  
On Cessna 172,182, and 206  
STC SA01700LA

**Models 206H, T206H – Pilot/Co-Pilot Seat Only AAIR System**

<u>Weight-lbs.</u>	<u>Arm-in.</u>	<u>Moment-in.lbs.</u>	
2.575	44.583	114.802	AAIR System Difference Added (EMA, P/N 508358-409)
(2.425)		108.113)	AAIR System Difference Added (EMA, P/N 508358-421)

**Models 206H, T206H – Middle Seat Only AAIR System**

<u>Weight-lbs.</u>	<u>Arm-in.</u>	<u>Moment-in.lbs.</u>	
3.875	65.382	253.356	AAIR System Difference Added (EMA, P/N 508358-409)
(3.725)		(243.547)	AAIR System Difference Added (EMA, P/N 508358-421)



Avionik Straubing GmbH  
 Flugplatz Wallmuehle  
 Flugplatzstraße 5  
 94348 Atting



DOA EASA.21J.046

Phone: +49 (0) 9429 9424-0  
 Fax: +49 (0) 9429 9424-24  
 eMail: entwicklung@avionik.de  
 www.avionik.de

ENGINEERING O/N°:	ASR-2008-011	AIRCRAFT SERIAL N°:	172S-10773
CRAFT	Cessna	AIRCRAFT MODEL:	172R,172S
MANUFACTURER:			

DOA-Center:	AVIONIK STRAUBING GmbH	Installation Center:	
DOA #:	EASA.21J.046	Repair Station #:	DE 145.0010
Address:	Flugplatz Wallmuehle 94348 Atting GERMANY	Address:	AVIONIK STRAUBING FLUGPLATZ WALLMUEHLE D-94348 ATTING TEL: 09429/9424-0, FAX: 09429/9424-24

## Operating Manual

DME

Bendix/King KN63

Aircraft Manufacturer: Cessna

Aircraft Model: 172R,172S

Aircraft Serial N°: 172S-10773

This document and the Manuals referenced herein must be carried in the aircraft at all times. They describe the operating procedures for the Bendix/King KN63 when it has been installed in accordance with Bendix/King KN63 Installation Manual P/N 006-00176-0004 Rev.4 and AVIONIK STRAUBING GmbH Order N° ASR-2008-011.

For aircraft with an Approved Airplane Flight Manual, this document serves as the Operating Manual for the Bendix/King KN63. For aircraft that do not have an approved Flight Manual, this document serves as the Approved Operating Manual for the Bendix/King KN63.

**The technical content of this Operating Manual is approved under the authority of EASA DOA 21J.046**







### Section I: General

1. The KN63 is a remote mounted, 200channel DME. All tuning is done electronically; using a single crystal, digital, frequency synthesizer. Range, speed, and time-to-station are measured digitally.
2. The KN63 is designed to operate with the panel mounted G1000 master indicator. The indicator receives DME range, speed, and time-to-station as digital serial data from the KN63.

### Section II: Limitations

No Change

### Section III: Emergency Procedure

No Change

### Section IV: Normal Procedures

1. In the Off position, the indicator and the remote mounted DME are all turned off. In N1 position, the DME is channeled from the NAV 1 control head. In N2 position, the DME is channeled from the NAV 2 control head. In Hold position, the DME is channeled to the last selected NAV 1 or NAV 2 frequency. To prevent the display of false information, the G1000 will display dashes and the KN 63 will stay in "search" whenever power is turned on or momentarily interrupted in frequency Hold mode.
2. The G1000 simultaneously display DME range, speed, and time-to-station.
3. When the KN 63 is locked to a ground station, range is displayed to the nearest 0.1 nautical mile from 0 to 99.9 nautical miles and to the nearest 1 nautical mile from 100 to 389 nautical miles. Ground speed is displayed to the nearest knot from 0 to 999 knots. Time-to-station is displayed to the nearest minute from 0 to 99 minutes. The indicators also show 99 minutes for any computed time-to-station greater than 99 minutes. When the KN 63 is in search mode, dashes are displayed instead of range, speed, and time-to-station.

### Section V: Performance

No Change

### Section VI: Weight and Balance

See current weight and balance data

### Section VII: Airplane and System Description

No Change



Avionik Straubing GmbH  
 Flugplatz Wallmuehle  
 Flugplatzstraße 5  
 94348 Atting



DOA EASA.21J.046

Phone: +49 (0) 9429 9424-0  
 Fax: +49 (0) 9429 9424-24  
 eMail: entwicklung@avionik.de  
 www.avionik.de

ENGINEERING O/N°:	ASR-2008-011	AIRCRAFT SERIAL N°:	172S16773
AIRCRAFT MANUFACTURER:	Cessna	AIRCRAFT MODEL:	172R,172S

DOA-Center:	AVIONIK STRAUBING GmbH	Installation Center:	
DOA #:	EASA.21J.046	Repair Station #:	DE.148.0010
Address:	Flugplatz Wallmuehle 94348 Atting GERMANY	Address:	AVIONIK STRAUBING FLUGPLATZ WALLMUEHLE D-94348 ATTING TEL 09429/9424-0, FAX 9424-24

## Operating Manual

ADF

Bendix/King KR87

Aircraft Manufacturer: Cessna  
 Aircraft Model: 172R,172S  
 Aircraft Serial N°: 172S16773

This document and the Manuals referenced herein must be carried in the aircraft at all times. They describe the operating procedures for the Bendix/King KR87 when it has been installed in accordance with Bendix/King KR87 Installation Manual P/N 006-00184-0006 Rev.6 and AVIONIK STRAUBING GmbH Order N° ASR-2008-011.

For aircraft with an Approved Airplane Flight Manual, this document serves as the Operating Manual for the Bendix/King KR87. For aircraft that do not have an approved Flight Manual, this document serves as the Approved Operating Manual for the Bendix/King KR87.

**The technical content of this Operating Manual is approved under the authority of EASA DOA 21J.046**







### Section I: General

KR87 Automatic Direction Finder is a digitally tuned solid state receiver which provides bearing information to station in the 200 KHz to 1799 KHz frequency band and which also provides audio reception to enable the pilot to identify station and listen to transcribed weather broadcasts or commercial radio station in the AM broadcast band.

### Section II: Limitations

No Change

### Section III: Emergency Procedure

No Change

### Section IV: Normal Procedures

The King KR87 features a gas-discharge display that displays the active ADF frequency in the left window. The right window will display either the standby frequency or a flight timer or programmable elapsed timer. The flight timer will keep track of the total flight time, while the independent programmable elapsed timer can be reset to count up from zero or preset to a value and count down to zero.

#### OPERATING MODES:

- Antenna mode is selected and annunciated when the ADF button is in the out position. ANT provides improved audio reception from the station tuned and is usually used for identification. The Bearing 1 Information is displayed to the lower left of the HSI and includes the bearing source (ADF) if selected. The Bearing 2 Information is displayed to the lower right of the HSI and includes the bearing source (ADF) if selected.
- DF mode is selected and annunciated when the ADF button is in the depressed position. ADF activated the bearing pointer in the G1000 indicator, causing it to move without hesitation to point in the direction of the station relative to aircraft heading.

### Section V: Performance

No Change

### Section VI: Weight and Balance

See current weight and balance data

### Section VII: Airplane and System Description

No Change





**charterware UG (haftungsbeschränkt)**

Otmar Ripp, Tel: +49 6502 9385667

*otmar.ripp@charterware.net*

**Doc No.: CS23var-010715-01-ASM-01, Rev.01**

# **Aircraft Flight Manual Supplement**

**Aircraft Interface for Flight Logger  
Charterware OBU**

**in**

**Aircraft Type and Model:** Cessna 172S OE-DCL

**Serial No.:** 172S 10773

**This Aircraft Flight Manual Supplement is approved by EASA under  
Approval No.:** 10054165



## **Section I: General**

This document describes an electrical interface (jack) mounted in the right half of the front panel. That jack is dedicated to connect a Charterware flight logger also called OBU (OnBoardUnit). The flight logger itself is not part of this installation. That device has to be handled as a PED. The pilot/operator must make sure that the applicable European respectively national operating rules (and the associated guidance material) are met.

## **Section II: Limitations**

Do not use the interface jack for other purposes than connecting a Charterware flight logger OBU

## **Section III: Emergency Procedures**

no change to basic flight manual

## **Section IV: Abnormal Procedures**

- in case of interference between the flight logger and aircraft instruments:
  - Pull the Sub-D connector out of the front panel mounted jack.

## **Section V: Normal Procedures**

Additional items for pre-flight check:

Ensure that the flight logger and its associated wiring is properly stowed and fixed.  
Check the flight logger plug for proper connection to the jack. Tighten the screws of the Sub-D connector only by hand without gloves. Do not use screwdrivers or other tools! Ensure that the plug can be removed immediately if necessary (see IV).

## **Section VI: Performance**

no change to basic flight manual

## **Section VII: Weight and Balance**

no change to basic flight manual

## **Section VIII: Technical Description**

For details concerning the flight logger see Charterware document User's Manual OBU.  
For details concerning the installation see Charterware Installation and Continued Airworthiness Manual **CS23var-010715-01-INM-01Rev.01**.  
For an installation example see annex 1.

**Annex 1: Example Photographs of the mounted Flight Logger**



Figure 1.1.: Jack for OBU Logger mounted within metallic faceblade of an instrument slot

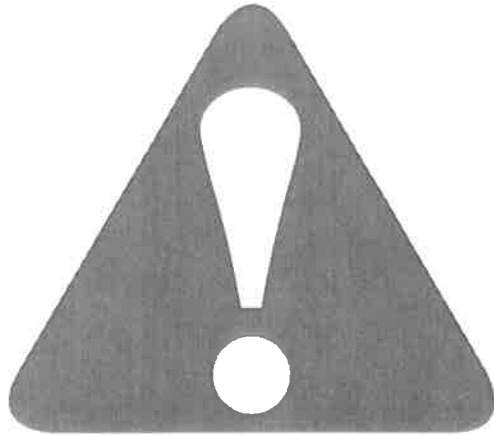

Figure 1.2.: OBU Logger during a flight in a typical Cockpit on Top Environment



TEXTRON AVIATION

# Pilot Safety and Warning Supplements



The information contained in this document is not intended to supersede the Owner's Manual or Pilot's Operating Handbook applicable to a specific airplane. If there is a conflict between this Pilot Safety and Warning Supplement and either the Owner's Manual or Pilot's Operating Handbook to a specific airplane, the Owner's Manual or Pilot's Operating Handbook shall take precedence. This publication replaces the original issue D5099-13 and the D5139-13 1 June 1998 Reissue in their entirety.

COPYRIGHT © 1998  
Cessna Aircraft Company  
Wichita, Kansas USA

 Member of GAMA

D5139-1-13

Original Issue - 2 October 1985  
Reissue - 1 June 1998  
Reissue 2 - 28 September 2018



**CONTENTS**

Supplement

**INTRODUCTION****FLIGHT CONSIDERATIONS**

Physiological . . . . .	1
Checklists . . . . .	2
Aircraft Loading . . . . .	3
Single Engine Flight Information (Multi-engine Airplanes) . . . . .	4
Pilot Proficiency . . . . .	5
Fuel Management . . . . .	6
Airframe Icing . . . . .	7
Weather . . . . .	8

**SYSTEM OPERATIONAL CONSIDERATIONS**

Restraint Systems . . . . .	9
Fuel System Contamination . . . . .	10
Fuel Pump Operation . . . . .	11
Auxiliary Fuel Tanks . . . . .	12
Instrument Power . . . . .	13
Alternate Air System . . . . .	14
Carbon Monoxide . . . . .	15
Turbocharger . . . . .	16
In-Flight Fires . . . . .	17
In-Flight Opening of Doors . . . . .	18
Autopilots and Electric Trim Systems . . . . .	19

**MAINTENANCE CONSIDERATIONS**

Maintenance . . . . .	20
Seat and Restraint Systems . . . . .	21
Exhaust and Fuel Systems . . . . .	22
Retractable Landing Gear . . . . .	23
Pressurized Airplanes . . . . .	24
Potential Hazards . . . . .	25



## INTRODUCTION

---

Pilots should know the information contained in the airplane's operating handbook, placards and checklists, and be familiar with service/maintenance publications, including service letters and bulletins, to ensure maximum safe utilization of the airplane. When the airplane was manufactured, it was equipped with a Pilot's Operating Handbook, Flight Manual, and/or Owner's Manual. If a handbook or manual is missing, a replacement should be obtained by contacting a Cessna Authorized Service Station.

In an effort to re-emphasize subjects that are generally known to most pilots, safety and operational information has been provided in the following Pilot Safety and Warning Supplements. As outlined in the table of contents, the Supplements are arranged numerically to make it easier to locate a particular Supplement. Supplement coverage is classified in three (3) categories: Flight Considerations, System Operational Considerations, and Maintenance Considerations. Most of the information relates to all Cessna airplanes, although a few Supplements are directed at operation of specific configurations such as multi-engine airplanes, pressurized airplanes, or airplanes certified for flight into known icing conditions.

Day-to-day safety practices play a key role in achieving maximum utilization of any piece of equipment.

### WARNING

**IT IS THE RESPONSIBILITY OF THE PILOT TO ENSURE THAT ALL ASPECTS OF PREFLIGHT PREPARATION ARE CONSIDERED BEFORE A FLIGHT IS INITIATED. ITEMS WHICH MUST BE CONSIDERED INCLUDE, BUT ARE NOT NECESSARILY LIMITED TO, THE FOLLOWING:**

- **PILOT PHYSICAL CONDITION AND PROFICIENCY**
- **AIRPLANE AIRWORTHINESS**
- **AIRPLANE EQUIPMENT APPROPRIATE FOR THE FLIGHT**
- **AIRPLANE LOADING AND WEIGHT AND BALANCE**
- **ROUTE OF THE FLIGHT**
- **WEATHER DURING THE FLIGHT**
- **FUEL QUANTITY REQUIRED FOR THE FLIGHT, INCLUDING ADEQUATE RESERVES**

(Continued Next Page)

**WARNING (CONTINUED)**

- **AIR TRAFFIC CONTROL AND EN-ROUTE NAVIGATION FACILITIES**
- **FACILITIES AT AIRPORTS OF INTENDED USE**
- **ADEQUACY OF AIRPORT (RUNWAY LENGTH, SLOPE, CONDITION, ETC.)**
- **LOCAL NOTICES, AND PUBLISHED NOTAMS**

**FAILURE TO CONSIDER THESE ITEMS COULD RESULT IN AN ACCIDENT CAUSING EXTENSIVE PROPERTY DAMAGE AND SERIOUS OR EVEN FATAL INJURIES TO THE PILOT, PASSENGERS, AND OTHER PEOPLE ON THE GROUND.**

The following Pilot Safety and Warning Supplements discuss in detail many of the subjects which must be considered by a pilot before embarking on any flight. Knowledge of this information is considered essential for safe, efficient operation of an airplane.

Proper flight safety begins long before the takeoff. A pilot's attitude toward safety and safe operation determines the thoroughness of the preflight preparation, including the assessment of the weather and airplane conditions and limitations. The pilot's physical and mental condition and proficiency are also major contributing factors. The use of current navigation charts, the Aeronautical Information Manual, NOTAMs, airport data, weather information, Advisory Circulars and training information, etc., is important. Individuals often develop their own personal methods for performing certain flight operations; however, it is required that these do not conflict with the limitations or recommended operating procedures for a specific airplane.

The pilot should know the Emergency Procedures for the airplane, since there may not be time to review the checklist in an emergency situation. It is essential that the pilot review the entire operating handbook to retain familiarity. He or she should maintain a working knowledge of the limitations of his or her airplane. When the pilot deliberately or inadvertently operates the airplane outside the limitations, he or she is violating Federal Aviation Regulations and may be subject to disciplinary actions.

Cessna does not support modifications to Cessna airplanes, whether by Supplemental Type Certificate or otherwise, unless these certificates are approved by Cessna. Such modifications, although approved by the FAA, may void any and all Cessna warranties on the airplane since Cessna may not know the full effects on the overall airplane. Cessna does not and has not tested and approved all such modifications by other companies. Maintenance and operating procedures and performance data provided by Cessna may no longer be accurate for the modified airplane.

Airplanes require maintenance on a regular basis. As a result, it is essential that the airplane be regularly inspected and repaired when parts are worn or damaged in order to maintain flight safety. Information for the proper maintenance of the airplane is found in the airplane Service/Maintenance Manual, Illustrated Parts Catalog, and in company-issued Service Information Letters or Service Bulletins, etc. Pilots should assure themselves that all recommendations for product changes or modifications called for by Service Bulletins, etc., are accomplished and that the airplane receives repetitive and required inspections.

Much of the subject matter discussed in the following Supplements has been derived from various publications of the U.S. Government. Since these documents contain considerably more information and detail than is contained here, it is highly recommended that the pilot also read them in order to gain an even greater understanding of the subjects related to flight safety. These publications include the following:

### **AERONAUTICAL INFORMATION MANUAL (AIM)**

This Federal Aviation Administration (FAA) manual is designed to provide airmen with basic flight information and Air Traffic Control (ATC) procedures for use in the National Airspace System (NAS). It also contains items of interest to pilots concerning health and medical facts, factors affecting flight safety, a pilot/controller glossary of terms used in the Air Traffic Control System, and information on safety, accident and hazard reporting. This manual can be purchased at retail dealers, or on a subscription basis from the Superintendent of Documents, U.S. Government Printing Office, Washington, D.C. 20402.

### **NOTICES TO AIRMEN (Class II)**

This is a publication containing current Notices to Airmen (NOTAMs) which are considered essential to the safety of flight as well as supplemental data affecting the other operational publications listed here. It also includes current Flight Data Center (FDC) NOTAMs, which are regulatory in nature, issued to establish restrictions to flight or amend charts or published Instrument Approach Procedures. This publication is issued every 14 days and is available by subscription from the Superintendent of Documents.

### **AIRPORT FACILITY DIRECTORY, ALASKA and PACIFIC CHART SUPPLEMENTS**

These publications contain information on airports, communications, navigation aids, instrument landing systems, VOR receiver checks, preferred routes, FSS/Weather Service telephone numbers, Air Route Traffic Control Center (ARTCC) frequencies, and various other pertinent special notices essential to air navigation. These publications are available by subscription from the National Ocean Service (NOS), NOAA N/ACC3 Distribution Division, Riverdale, Maryland 20737, telephone 1-800-638-8972 FAX (301) 436-6829.

**FEDERAL AVIATION REGULATIONS (FARs)**

The FAA publishes the FARs to make readily available to the aviation community the regulatory requirements placed upon them. These regulations are sold as individual parts by the Superintendent of Documents. The more frequently amended parts are sold by subscription service with subscribers receiving changes automatically as they are issued. Less active parts are sold on a single-sale basis. Changes to single-sale parts will be sold separately as issued. Information concerning these changes will be furnished by the FAA through its Status of Federal Aviation Regulations, AC 00-44II.

**ADVISORY CIRCULARS (ACs)**

The FAA issues ACs to inform the aviation public of non regulatory material of interest. Advisory Circulars are issued in a numbered subject system corresponding to the subject areas of the Federal Aviation Regulations. AC 00-2.11, Advisory Circular Checklist contains a listing of ACs covering a wide range of subjects and how to order them, many of which are distributed free-of-charge.

AC 00-2.11 is issued every four months and is available at no cost from: U.S. Department of Transportation, Distribution requirements Section, SVC 121.21, Washington, DC 20590. The checklist is also available via the Internet at <http://www.faa.gov/abc/ac-chklist/actoc.htm>.

## PHYSIOLOGICAL

---

### FATIGUE

Fatigue continues to be one of the most treacherous hazards to flight safety. It generally slows reaction times and causes errors due to inattention, and it may not be apparent to a pilot until serious errors are made. Fatigue is best described as either acute (short-term) or chronic (long-term). As a normal occurrence of everyday living, acute fatigue is the tiredness felt after long periods of physical and/or mental strain, including strenuous muscular effort, immobility, heavy mental workload, strong emotional pressure, monotony, and lack of sleep. In addition to these common causes, the pressures of business, financial worries, and unique family problems can be important contributing factors. Consequently, coordination and alertness, which are vital to safe pilot performance, can be reduced. Acute fatigue can be prevented by adequate rest and sleep, as well as regular exercise and proper nutrition.

Chronic fatigue occurs when there is insufficient time for full recovery between periods of acute fatigue. Performance continues to degrade and judgment becomes impaired so that unwarranted risks may be taken. Recovery from chronic fatigue requires a prolonged period of rest. If a pilot is markedly fatigued prior to a given flight, he or she should not fly. To prevent cumulative fatigue effects during long flights, pilots should conscientiously make efforts to remain mentally active by making frequent visual and radio navigation position checks, estimates of time of arrival at the next check point, etc.

### STRESS

Stress from the pressures of everyday living can impair pilot performance, often in very subtle ways. Difficulties can occupy thought processes enough to markedly decrease alertness. Distractions can also interfere with judgment to the point that unwarranted risks are taken, such as flying into deteriorating weather conditions to keep on schedule. Stress and fatigue can be an extremely hazardous combination.

It is virtually impossible to leave stress on the ground. Therefore, when more than usual difficulties are being experienced, a pilot should consider delaying flight until these difficulties are satisfactorily resolved.

### EMOTION

Certain emotionally upsetting events, including a serious argument, death of a family member, separation or divorce, loss of job, or financial catastrophe can seriously impair a pilot's ability to fly an airplane safely. The emotions of anger, depression, and anxiety from such events not

only decrease alertness but may also lead to taking unnecessary risks. Any pilot who experiences an emotionally upsetting event should not fly until satisfactorily recovered from the event.

## **ILLNESS**

A pilot should not fly with a known medical condition or a change of a known medical condition that would make the pilot unable to meet medical certificate standards. Even a minor illness suffered in day-to-day living can seriously degrade performance of many piloting skills vital to safe flight. An illness may produce a fever and other distracting symptoms that can impair judgment, memory, alertness, and the ability to make decisions. Even if the symptoms of an illness are under adequate control with a medication, the medication may adversely affect pilot performance, and invalidate his or her medical certificate.

The safest approach is not to fly while suffering from any illness. If there is doubt about a particular illness, the pilot should contact an Aviation Medical Examiner for advice.

## **MEDICATION**

Pilot performance can be seriously degraded by both prescribed and over-the-counter medications. Many medications, such as tranquilizers, sedatives, strong pain relievers, and cough suppressant preparations, have primary effects that may impair judgment, memory, alertness, coordination, vision, and ability to make decisions. Other medications, such as antihistamines, blood pressure drugs, muscle relaxants, and agents to control diarrhea and motion sickness, have side effects that may impair the body's critical functions. Any medications that depress the nervous system, such as a sedative, tranquilizer or antihistamine, can make a pilot more susceptible to hypoxia.

FARs prohibit pilots from flying while using any medication that affects their faculties in any way contrary to safety. The safest advice is to not fly while taking medications, unless approved to do so by an Aviation Medical Examiner. The condition for which the drug is required may itself be very hazardous to flying, even when the symptoms are suppressed by the drug. A combination of medications may cause adverse effects that do not result from a single medication.

## **ALCOHOL**

Do not fly while under the influence of alcohol. Flying and alcohol are definitely a lethal combination. FARs prohibit pilots from flying within 8 hours after consuming any alcoholic beverage or while under the influence of alcohol. A pilot may still be under the influence 8 hours after drinking a moderate amount of alcohol. Therefore, an excellent

practice is to allow at least 24 hours between "bottle and throttle," depending on the amount of alcoholic beverage consumed.

Extensive research has provided a number of facts about the hazards of alcohol consumption and flying. As little as one ounce of liquor, one bottle of beer, or four ounces of wine can impair flying skills, with the alcohol consumed in these drinks being detectable in the breath and blood for at least three hours. Alcohol also renders a pilot much more susceptible to disorientation and hypoxia. In addition, the after effects of alcohol increase the level of fatigue significantly.

There is simply no way of alleviating a hangover. Remember that the human body metabolizes alcohol at a fixed rate, and no amount of coffee or medications will alter this rate. Do not fly with a hangover, or a "masked hangover" (symptoms suppressed by aspirin or other medication). A pilot can be severely impaired for many hours by hangover.

## **DRINKING THE RIGHT FLUIDS**

One of the main sources of pilot and passenger complaints stems from the relatively lowered humidity during air travel encountered at altitude particularly on extended flights. Even though an individual may not be physically active, body water is continuously expired from the lungs and through the skin. This physiological phenomenon is called insensible perspiration or insensible loss of water.

The loss of water through the skin, lungs, and kidneys never ceases. Water loss is increased with exercise, fever, and in some disease conditions such as hyperthyroidism. Combating the effects of insensible water loss during flight requires frequent water intake. Unless this is done, dehydration will occur and this causes interference with blood circulation, tissue metabolism, and excretion of the kidneys. Water is vital for the normal chemical reaction of human tissue. It is also necessary for the regulation of body temperature and as an excretory medium.

Beginning a flight in a rested, healthy condition is of prime importance. Proper water balance through frequent fluid intake relieves the adverse effects produced by insensible water loss in an atmosphere of lowered humidity. Typical dehydration conditions are: dryness of the tissues and resulting irritation of the eyes, nose, and throat as well as other conditions previously mentioned plus the associated fatigue relating to the state of acidosis (reduced alkalinity of the blood and the body tissues). A person reporting for a flight in a dehydrated state will more readily notice these symptoms until fluids are adequately replaced. Consumption of coffee, tea, cola, and cocoa should be minimized since these drinks contain caffeine. In addition, tea contains a related drug, theophylline, while cocoa (and chocolate) contain theobromine, of the same drug group. These drugs, besides having a diuretic effect, have a marked stimulating effect and can cause an increase in pulse rate,

elevation of blood pressure, stimulation of digestive fluid formation, and irritability of the gastrointestinal tract.

## **HYPOXIA**

Hypoxia, in simple terms, is a lack of sufficient oxygen to keep the brain and other body tissues functioning properly. Wide individual variation occurs with respect to susceptibility to and symptoms of hypoxia. In addition to progressively insufficient oxygen at higher altitudes, anything interfering with the blood's ability to carry oxygen can contribute to hypoxia (e.g., anemias, carbon monoxide, and certain drugs). Also, alcohol and various other drugs decrease the brain's tolerance to hypoxia. A human body has no built-in alarm system to let the pilot know when he is not getting enough oxygen. It is difficult to predict when or where hypoxia will occur during a given flight, or how it will manifest itself.

Although a deterioration in night vision occurs at a cabin pressure altitude as low as 5000 feet, other significant effects of altitude hypoxia usually do not occur in a normal healthy pilot below 12,000 feet. From 12,000 to 15,000 feet of altitude, judgment, memory, alertness, coordination, and ability to make decisions are impaired, and headache, drowsiness, dizziness, and either a sense of well-being (euphoria) or belligerence occurs. The effects appear following increasingly shorter periods of exposure to increasing altitude. In fact, a pilot's performance can seriously deteriorate within 15 minutes at 15,000 feet. At cabin pressures above 15,000 feet, the periphery of the visual field grays out to a point where only central vision remains (tunnel vision). A blue coloration (cyanosis) of the fingernails and lips develops and the ability to take corrective and protective action is lost in 20 to 30 minutes at 18,000 feet and 5 to 12 minutes at 20,000 feet, followed soon thereafter by unconsciousness.

The altitude at which significant effects of hypoxia occur can be lowered by a number of factors. Carbon monoxide inhaled in smoking or from exhaust fumes, lowered hemoglobin (anemia), and certain medications can reduce the oxygen-carrying capacity of the blood to the degree that the amount of oxygen provided to body tissues will already be equivalent to the oxygen provided to the tissues when exposed to a cabin pressure altitude of several thousand feet. Small amounts of alcohol and low doses of certain drugs, such as antihistamines, tranquilizers, sedatives, and analgesics can, through their depressant action, render the brain much more susceptible to hypoxia. Extreme heat and cold, fever, and anxiety increase the body's demand for oxygen, and hence, its susceptibility to hypoxia.

Current regulations require that pilots use supplemental oxygen after 30 minutes of exposure to cabin pressure altitudes between 12,500 and 14,000 feet and immediately upon exposure to cabin pressure altitudes above 14,000 feet. Every occupant of the airplane must be

provided with supplemental oxygen at cabin pressure altitudes above 15,000 feet.

Hypoxia can be prevented by avoiding factors that reduce tolerance to altitude, by enriching the air with oxygen from an appropriate oxygen system, and by maintaining a comfortable, safe cabin pressure altitude. For optimum protection, pilots are encouraged to use supplemental oxygen above 10,000 feet during the day, and above 5000 feet at night.

### **NOTE**

When using oxygen systems that do not supply "pressure breathing", 100% oxygen cannot maintain proper blood oxygen level above 25,000 feet altitude. Pilot's must be familiar with limitations of the airplane oxygen system.

Pilots are encouraged to attend physiological training and susceptibility testing in a high-altitude chamber to experience and make note of their own personal reactions to the effects of hypoxia. These chambers are located at the FAA Civil Aeromedical Institute and many governmental and military facilities. Knowing before hand what your own early symptoms of hypoxia are will allow a greater time margin for taking corrective action. The corrective action, should symptoms be noticed, is to use supplemental oxygen and/or decrease cabin altitude. These actions must not be delayed.

### **SMOKING**

Smokers are slightly resistant to the initial symptoms of hypoxia. Because of this, smokers risk the possibility of delayed detection of hypoxia. Pilots should avoid any detrimental factors, such as second hand smoke, which can cause such insensitivity. The small merit of hypoxic tolerance in smokers will do more harm than good by rendering them insensitive and unaware of the hypoxic symptoms.

Smoking in the cabin of the airplane exposes other passengers to high concentrations of noxious gas and residue. Furthermore, many of the systems of the airplane are contaminated and deteriorated by long-term exposure to smoking residue. Due to the large number of known dangers and hazards, as well as those which are still the subject of research, it is strongly recommended that smoking not take place in flight.

### **WARNING**

**SMOKING WHILE OXYGEN SYSTEMS ARE IN USE  
CREATES AN EXTREME FIRE HAZARD.**

## **HYPERVENTILATION**

Hyperventilation, or an abnormal increase in the volume of air breathed in and out of the lungs, can occur subconsciously when a stressful situation is encountered in flight. As hyperventilation expels excessive carbon dioxide from the body, a pilot can experience symptoms of light headedness, suffocation, drowsiness, tingling in the extremities, and coolness -- and react to them with even greater hyperventilation. Incapacitation can eventually result. Uncoordination, disorientation, painful muscle spasms, and finally, unconsciousness may ultimately occur.

The symptoms of hyperventilation will subside within a few minutes if the rate and depth of breathing are consciously brought back under control. The restoration of normal carbon dioxide levels in the body can be hastened by controlled breathing in and out of a paper bag held over the nose and mouth.

Early symptoms of hyperventilation and hypoxia are similar. Moreover, hyperventilation and hypoxia can occur at the same time. Therefore, if a pilot is using oxygen when symptoms are experienced, the oxygen system should be checked to assure that it has been functioning effectively before giving attention to rate and depth of breathing.

## **EAR BLOCK**

As an airplane climbs and the cabin pressure decreases, trapped air in the middle ear expands and escapes through the eustachian tube to the nasal passages, thus equalizing with the pressure in the cabin. During descent, cabin pressure increases and some air must return to the middle ear through the eustachian tube to maintain equal pressure. However, this process does not always occur without effort. In most cases it can be accomplished by swallowing, yawning, tensing the muscles in the throat or, if these do not work, by the combination of closing the mouth, pinching the nose closed, and attempting to blow gently through the nostrils (Valsalva maneuver).

Either an upper respiratory infection, such as a cold or sore throat, or a nasal allergic condition can produce enough congestion around the eustachian tube to make equalization difficult. Consequently, the difference in pressure between the middle ear and the airplane cabin can build up to a level that will hold the eustachian tube closed, making equalization difficult, if not impossible. This situation is commonly referred to as an "ear block." An ear block produces severe pain and loss of hearing that can last from several hours to several days. Rupture of the ear drum can occur in flight or after landing. Fluid can accumulate in the middle ear and become infected. If an ear block is experienced and does not clear shortly after landing, a physician should be consulted. Decongestant sprays or drops to reduce congestion usually do not provide adequate protection around the eustachian tubes. Oral decongestants have side effects that can

significantly impair pilot performance. An ear block can be prevented by not flying with an upper respiratory infection or nasal allergic condition.

## **SINUS BLOCK**

During climb and descent, air pressure in the sinuses equalizes with the airplane cabin pressure through small openings that connect the sinuses to the nasal passages. Either an upper respiratory infection, such as a cold or sinusitis, or a nasal allergic condition can produce enough congestion around the openings to slow equalization, and as the difference in pressure between the sinus and cabin increases, eventually the openings plug. This "sinus block" occurs most frequently during descent.

A sinus block can occur in the frontal sinuses, located above each eyebrow, or in the maxillary sinuses, located in each upper cheek. It will usually produce excruciating pain over the sinus area. A maxillary sinus block can also make the upper teeth ache. Bloody mucus may discharge from nasal passages. A sinus block can be prevented by not flying with an upper respiratory infection or nasal allergic condition. If a sinus block does occur and does not clear shortly after landing, a physician should be consulted.

## **VISION IN FLIGHT**

Of all the pilot's senses, vision is the most critical to safe flight. The level of illumination is the major factor to adequate in-flight vision. Details on flight instruments or aeronautical charts become difficult to discern under dimly lit conditions. Likewise, the detection of other aircraft is much more difficult under such conditions.

In darkness, vision becomes more sensitive to light, a process called dark adaptation. Although exposure to total darkness for at least 30 minutes is required for complete dark adaptation, a pilot can achieve a moderate degree of dark adaptation within 20 minutes under dim red lighting. Since red light severely distorts colors, especially on aeronautical charts, and can cause serious difficulty in focusing the eyes on objects inside the cabin, its use is advisable only where optimum outside night vision is necessary. Even so, white flight station lighting must be available when needed for map and instrument reading, especially while under IFR conditions. Dark adaptation is impaired by exposure to cabin pressure altitudes above 5000 feet, carbon monoxide inhaled in smoking and from exhaust fumes, deficiency of vitamin A in the diet, and by prolonged exposure to bright sunlight. Since any degree of dark adaptation is lost within a few seconds of viewing a bright light, pilots should close one eye when using a light to preserve some degree of night vision. In addition, use of sunglasses during the day will help speed the process of dark adaptation during night flight.

## **SCUBA DIVING**

A pilot or passenger who flies shortly after prolonged scuba diving could be in serious danger. Anyone who intends to fly after scuba diving should allow the body sufficient time to rid itself of excess nitrogen absorbed during diving. If not, decompression sickness (commonly referred to as the "bends"), due to dissolved gas, can occur even at low altitude and create a serious in-flight emergency. The recommended waiting time before flight to cabin altitudes of 8000 feet or less is at least 12 hours after diving which has not required controlled ascent (non-decompression diving), and at least 24 hours after diving which has required a controlled ascent (decompression diving). The waiting time before flight to cabin pressure altitudes above 8000 feet should be at least 24 hours after any scuba diving.

## **AEROBATIC FLIGHT**

Pilots planning to engage in aerobatic maneuvers should be aware of the physiological stresses associated with accelerative forces during such maneuvers. Forces experienced with a rapid push-over maneuver will result in the blood and body organs being displaced toward the head. Depending on the forces involved and the individual tolerance, the pilot may experience discomfort, headache, "red-out", and even unconsciousness. Forces experienced with a rapid pull-up maneuver result in the blood and body organs being displaced toward the lower part of the body away from the head. Since the brain requires continuous blood circulation for an adequate oxygen supply, there is a physiological limit to the time the pilot can tolerate higher forces before losing consciousness. As the blood circulation to the brain decreases as a result of the forces involved, the pilot will experience "narrowing" of visual fields, "gray-out", "black-out", and unconsciousness.

Physiologically, humans progressively adapt to imposed strains and stresses, and with practice, any maneuver will have a decreasing effect. Tolerance to "G" forces is dependent on human physiology and the individual pilot. These factors include the skeletal anatomy, the cardiovascular architecture, the nervous system, blood make-up, the general physical state, and experience and recency of exposure. A pilot should consult an Aviation Medical Examiner prior to aerobatic training and be aware that poor physical condition can reduce tolerance to accelerative forces.

## CHECKLISTS

---

### CONSISTENT USE

Airplane checklists are available for those persons who do not wish to use the operating handbook on every flight. These checklists contain excerpts from the operating handbook written for that particular airplane and are designed to remind pilots of the minimum items to check for safe operation of the airplane, without providing details concerning the operation of any particular system. Checklists should be used by the pilot and not placed in the seat pocket and forgotten. Even pilots who consistently carry the checklists tend to memorize certain areas and intentionally overlook these procedural references. Consequently, in time, these individuals find that operating something as complex as an airplane on memory alone is practically impossible, and eventually, could find themselves in trouble because one or more important items are overlooked or completely forgotten. The consistent use of all checklists is required for the safe operation of an airplane.

#### NOTE

Abbreviated checklists can be used in place of the airplane operating manual. However, they should be used only after the pilot becomes familiar with the airplane operating manual, and thoroughly understands the required procedures for airplane operation.

### CONTRIBUTIONS TO SAFETY

Most large airplanes in the transport category are flown by consistent use of all checklists. Experience has shown that pilots who consistently use checklists on every flight maintain higher overall proficiency, and have better safety records. The pilot should not become preoccupied inside the cockpit and fail to remain alert for situations outside the airplane.

### CHECKLIST ARRANGEMENT (ORGANIZATION OF ITEMS)

Abbreviated checklists are written in a concise form to provide pilots with a means of complying with established requirements for the safe operation of their airplane. The checklists are usually arranged by "Item" and "Condition" headings. The item to be checked is listed with the desired condition stated. Key words or switch and lever positions are usually emphasized by capitalization in the "Condition" column. The checklist may also contain supplemental information pertinent to the operation of the airplane, such as performance data, optional equipment operation, etc., that the pilot might routinely use.

## EMERGENCY CHECKLISTS

Emergency checklists are provided for emergency situations peculiar to a particular airplane design, operating or handling characteristic. Pilots should periodically review the airplane operating handbook to be completely familiar with information published by the manufacturer concerning the airplane. Emergency situations are never planned and may occur at the worst possible time. During most emergency conditions, there will not be sufficient time to refer to an emergency checklist; therefore, it is essential that the pilot commit to memory those emergency procedures that may be shown in **bold-face** type or outlined with a black border, within the emergency procedures section in operating handbooks or equivalent hand-held checklists. These items are essential for continued safe flight. After the emergency situation is under control, the pilot should complete the checklist in its entirety, in the proper sequence, and confirm that all items have been accomplished. It is essential that the pilot review and know published emergency checklists and any other emergency procedures. Familiarity with the airplane and its systems and a high degree of pilot proficiency are valuable assets if an emergency should arise.

## **AIRPLANE LOADING**

---

### **AIRPLANE CENTER-OF-GRAVITY RANGE**

Pilots should never become complacent about the weight and balance limitations of an airplane, and the reasons for these limitations. Since weight and balance are vital to safe airplane operation, every pilot should have a thorough understanding of airplane loading, with its limitations, and the principles of airplane balance. Airplane balance is maintained by controlling the position of the center-of-gravity. Overloading, or misloading, may not result in obvious structural damage, but could do harm to hidden structure or produce a dangerous situation in the event of an emergency under those conditions. Overloading, or misloading may also produce hazardous airplane handling characteristics.

There are several different weights to be considered when dealing with airplane weight and balance. These are defined in another paragraph in this supplement. Airplanes are designed with predetermined structural limitations to meet certain performance and flight characteristics and standards. Their balance is determined by the relationship of the center-of-gravity (C.G.) to the center of lift. Normally, the C.G. of an airplane is located slightly forward of the center of lift. The pilot can safely use the airplane flight controls to maintain stabilized balance of the airplane as long as the C.G. is located within specified forward and aft limits. The allowable variation of the C.G. location is called the center-of-gravity range. The exact location of the allowable C.G. range is specified in the operating handbook for that particular airplane.

### **LOCATING THE LOAD**

It is the responsibility of the pilot to ensure that the airplane is loaded properly. Operation outside of prescribed weight and balance limitations could result in an accident and serious or fatal injury.

To determine the center-of-gravity (C.G.) of an airplane, a pilot must have an understanding of the three terms used in weight and balance calculations. These terms are weight, moment, and arm. The principles associated with these terms are applied to each occupant, piece of cargo or baggage, the airplane itself, and all the fuel to determine the overall C.G. of the airplane.

The weight of an object should be carefully determined or calculated. All weights must be measured in the same units as the aircraft empty weight. The arm is the distance that the weight of a particular item is located from the reference datum line or the imaginary vertical line from which all horizontal distances are measured for balance purposes (refer to examples in Figure 1).

The word "moment", as used in airplane loading procedures, is the product of the weight of the object multiplied by the arm.

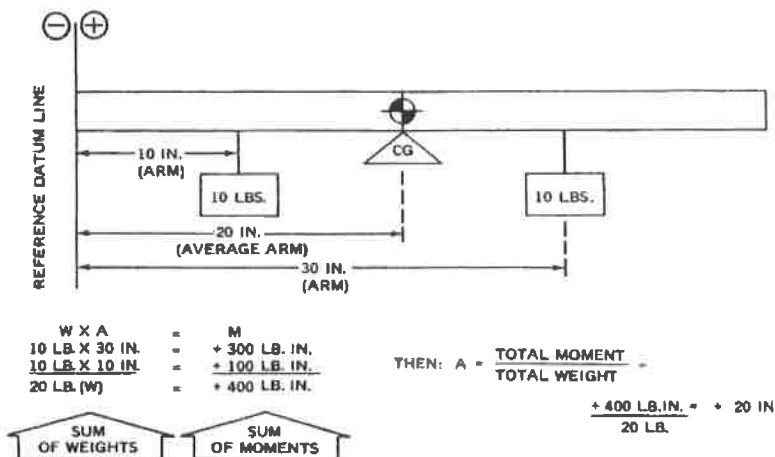

Figure 1. Computing the Center-of-Gravity

Pilots can remember and use the relationship of these terms most easily by arranging them in a mathematical triangle:



weight × arm = moment  
moment ÷ weight = arm  
moment ÷ arm = weight

The relative position of any two terms indicates the mathematical process (multiplication or division) required to compute the third term.

A loading graph or loading tables, a center-of-gravity limits chart and/or a center-of-gravity moment envelope chart, as well as a sample loading problem are provided in most airplane operating handbooks. By following the narrative directions, the pilot can determine the correct airplane C.G. for any configuration of the airplane. If the position of the load is different from that shown on the loading graph or in the loading tables, additional moment calculations, based on the actual weight and C.G. arm (fuselage station) of the item being loaded, must be performed.

## **LOAD SECURITY**

In addition to the security of passengers, it is the pilot's responsibility to determine that all cargo and/or baggage is secured before flight. When required, the airplane may be equipped with tie-down rings or fittings for the purpose of securing cargo or baggage in the baggage compartment or cabin area. The maximum allowable cargo loads to be carried are determined by cargo weight limitations, the type and number of tie-downs used, as well as by the airplane weight and C.G. limitations. Always carefully observe all precautions listed in the operating handbook concerning cargo tie-down.

Pilots should assist in ensuring seat security and proper restraint for all passengers. Pilots should also advise passengers not to put heavy or sharp items under occupied seats since these items may interfere with the seats' energy absorption characteristics in the event of a crash.

Optional equipment installed in the airplane can affect loading, and the airplane center-of-gravity. Under certain loading conditions in tricycle gear airplanes, it is possible to exceed the aft C.G. limit, which could cause the airplane to tip and allow the fuselage tailcone to strike the ground while loading the airplane. The force of a tail ground strike could damage internal structure, resulting in possible interference with elevator control system operation.

## **EFFECTS OF LOADING ON THE FLIGHT**

Weight and balance limits are placed on airplanes for three principal reasons: first, the effect of the weight on the primary and secondary structures; second, the effect on airplane performance; and third, the effect on flight controllability, particularly in stall and spin recovery.

A knowledge of load factors in flight maneuvers and gusts is important for understanding how an increase in maximum weight affects the characteristics of an airplane. The structure of an airplane subjected to a load factor of 3 Gs, must be capable of withstanding an added load of three hundred pounds for each hundred pound increase in weight. All Cessna airplanes are analyzed and tested for flight at the maximum authorized weight, and within the speeds posted for the type of flight to be performed. Flight at weights in excess of this amount may be possible, but loads for which the airplane was not designed may be imposed on all or some part of the structure.

An airplane loaded to the rear limit of its permissible center-of-gravity range will respond differently than when it is loaded near the forward limit. The stall characteristics of an airplane change as the airplane load changes, and stall characteristics become progressively better as center-of-gravity moves forward. Distribution of weight can also have a significant effect on spin characteristics. Forward location of the C.G. will usually make it more difficult to obtain a spin. Conversely, extremely aft C.G. locations will tend to promote lengthened recoveries since a

more complete stall can be achieved. Changes in airplane weight as well as its distribution can have an effect on spin characteristics since increases in weight will increase inertia. Higher weights may delay recoveries.

An airplane loaded beyond the forward C.G. limit will be nose heavy, and can be difficult to rotate for takeoff or flare for landing. Airplanes with tail wheels can be nosed over more easily.

### **LOAD AND LATERAL TRIM**

Some airplanes have a maximum limit for wing fuel lateral imbalance and/or a maximum wing locker load limitation. These limitations are required for one or both of two primary reasons. The first is to ensure that the airplane will maintain certain roll responses mandated by its certification. The other is to prevent overheating and interruption of lateral trim on certain types of autopilots caused by the excessive work required to maintain a wings level attitude while one wing is heavier than the other. Pilots should carefully observe such limitations and keep the fuel balance within the limits set forth in the respective operating handbook.

### **WEIGHT AND BALANCE TERMINOLOGY**

The following list is provided in order to familiarize pilots and owners with the terminology used in calculating the weight and balance of Cessna airplanes. (Some terminology listed herein is defined and used in Pilot's Operating Handbooks only.)

Arm	The horizontal distance from the reference datum to the center-of-gravity (C.G.) of an item.
Basic Empty Weight	The standard empty weight plus the weight of installed optional equipment.
C.G. Arm	The arm obtained by adding the airplane's individual moments and dividing the sum by the total weight.
C.G. Limits	The extreme center-of-gravity locations within which the airplane must be operated at a given weight.

Center-of-Gravity (C.G.)	The point at which an airplane or item of equipment would balance if suspended. Its distance from the reference datum is found by dividing the total moment by the total weight of the airplane or item of equipment.
MAC	The mean aerodynamic chord of a wing is the chord of an imaginary airfoil which throughout the flight range will have the same force vectors as those of the wing.
Maximum Landing Weight	The maximum weight approved for the landing touchdown.
Maximum Ramp Weight	The maximum weight approved for ground maneuvers. It includes the weight of start, taxi and run up fuel.
Maximum Takeoff Weight	The maximum weight approved for the start of the takeoff roll.
Maximum Zero Fuel Weight	The maximum weight exclusive of usable fuel.
Moment	The product of the weight of an item multiplied by its arm. (Moment divided by a constant is used to simplify balance calculations by reducing the number of digits.)
Payload	The weight of occupants, cargo, and baggage.
Reference Datum	An imaginary vertical plane from which all horizontal distances are measured for balance purposes.
Standard Empty Weight	The weight of a standard airplane, including unusable fuel, full operating fluids and full engine oil. In those manuals which refer to this weight as Licensed Empty Weight, the weight of engine oil is not included and must be added separately in weight and balance calculations.
Station	A location along the airplane fuselage given in terms of the distance from the reference datum.

Tare	The weight of chocks, blocks, stands, etc., used when weighing an airplane, and is included in the scale readings. Tare is deducted from the scale reading to obtain the actual (net) airplane weight.
Unusable Fuel	The quantity of fuel that cannot be safely used in flight.
Usable Fuel	The fuel available for flight planning.
Useful Load	The difference between ramp weight and the basic empty weight.

## **SINGLE ENGINE FLIGHT INFORMATION (MULTI-ENGINE AIRPLANES)**

---

### **INTRODUCTION**

The following discussion is intended primarily for pilots of propeller-driven, light twin-engine airplanes, powered by reciprocating engines and certified under CAR Part 3 or FAR Part 23. This discussion is not intended to apply to specific models, but is intended, instead, to give general guidelines or recommendations for operations in the event of an engine failure during flight.

### **SINGLE ENGINE TAKEOFF AND CLIMB**

Each time a pilot considers a takeoff in a twin-engine airplane, knowledge is required of the Minimum Control Speed ( $V_{MC}$ ) for that particular airplane. Knowledge of this speed, is essential to ensure safe operation of the airplane in the event an engine power loss occurs during the most critical phases of flight, the takeoff and initial climb.

$V_{MC}$  is the minimum flight speed at which the airplane is directionally and laterally controllable as determined in accordance with Federal Aviation Regulations. Airplane certification conditions include: one engine becoming inoperative and windmilling; not more than a 5-degree bank toward the operative engine; takeoff power on the operative engine; landing gear retracted; flaps in the takeoff position; and the most critical C.G. (center of gravity). A multi-engine airplane must reach the minimum control speed before full control deflections can counteract the adverse rolling and/or yawing tendencies associated with one engine inoperative and full power operation on the other engine. The most critical time for an engine failure is during a two or three second period, late in the takeoff, while the airplane is accelerating to a safe speed.

Should an engine failure be experienced before liftoff speed is reached, the takeoff must be aborted. If an engine failure occurs immediately after liftoff, but before the landing gear is retracted, continue takeoff while retracting gear. Abort takeoff only if sufficient runway is available. This decision should be made before the takeoff is initiated.

The pilot of a twin-engine airplane must exercise good judgment and take prompt action in the decision whether or not to abort a takeoff attempt following an engine failure, since many factors will influence the decision.

Some of these factors include: runway length, grade and surface condition (i.e., slippery, dry, etc.), field elevation, temperature, wind speed and direction, terrain or obstructions in the vicinity of the runway,

airplane weight and single engine climb capability under the prevailing conditions, among others. The pilot should abort the takeoff, following an engine-out, even if the airplane has lifted off the runway, if runway conditions permit. However, under limited circumstances (i.e., short runway with obstructions) the pilot may have to continue the takeoff following a liftoff and an engine-out.

While it may be possible to continue the takeoff at light weights and with favorable atmospheric conditions following an engine failure just after liftoff, long distances are required to clear even small obstacles. Distances required to clear an obstacle are reduced under more favorable combinations of weight, headwind component, or obstacle height.

The pilot's decision to continue the takeoff after an engine failure should be based on consideration of either the single engine best angle-of-climb speed ( $V_{XSE}$ ) if an obstacle is ahead, or the single engine best rate-of-climb speed ( $V_{YSE}$ ) when no obstacles are present in the climb area. Once the single engine best angle-of-climb speed is reached, altitude becomes more important than airspeed until the obstacle is cleared. On the other hand, the single engine best rate-of-climb speed becomes more important when there are no obstacles ahead. Refer to the Owners Manual, Flight Manual or Pilot's Operating Handbook for the proper airspeeds and procedures to be used in the event of an engine failure during takeoff. Refer to the warning placard "To Continue Flight With An Inoperative Engine" in the airplane's operating handbook and/or on the instrument panel for additional information.

Should an engine failure occur at or above these prescribed airspeeds, the airplane, within the limitations of its single engine climb performance, should be maneuvered to a landing. After the airplane has been "cleaned up" following an engine failure (landing gear and wing flaps retracted and the propeller feathered on the inoperative engine), it may be accelerated to its single engine best rate-of-climb speed. If immediate obstructions so dictate, the single engine best angle-of-climb speed may be maintained until the obstacles are cleared. In no case should the speed be allowed to drop below single engine best angle-of-climb speed unless an immediate landing is planned, since airplane performance capabilities will deteriorate rapidly as the airspeed decreases. After clearing all immediate obstacles, the airplane should be accelerated slowly to its single engine best rate-of-climb speed and the climb continued to a safe altitude which will allow maneuvering for a return to the airport for landing.

To obtain single engine best climb performance with one engine inoperative, the airplane must be flown in a 3 to 5 degree bank toward the operating engine. The rudder is used to maintain straight flight, compensating for the asymmetrical engine power. The ball of the

turn-and-bank indicator should not be centered, but should be displaced about 1/2 ball width toward the operating engine.

The propeller on the inoperative engine must be feathered, the landing gear retracted, and the wing flaps retracted for continued safe flight. Climb performance of an airplane with a propeller windmilling usually is nonexistent. Once the decision to feather a propeller has been made, the pilot should ensure that the propeller feathers properly and remains feathered. The landing gear and wing flaps also cause a severe reduction in climb performance and both should be retracted as soon as possible (in accordance with the operating handbook limitations).

The following general facts should be used as a guide if an engine failure occurs during or immediately after takeoff:

1. Discontinuing a takeoff upon encountering an engine failure is advisable under most circumstances. Continuing the takeoff, if an engine failure occurs prior to reaching single engine best angle-of-climb speed and landing gear retraction, is not advisable.
2. Altitude is more valuable to safety immediately after takeoff than is airspeed in excess of the single engine best angle-of-climb speed.
3. A windmilling propeller and extended landing gear cause a severe drag penalty and, therefore, climb or continued level flight is improbable, depending on weight, altitude and temperature. Prompt retraction of the landing gear (except Model 337 series), identification of the inoperative engine, and feathering of the propeller is of utmost importance if the takeoff is to be continued.
4. Unless touchdown is imminent, in no case should airspeed be allowed to fall below single engine best angle-of-climb speed even though altitude is lost, since any lesser speed will result in significantly reduced climb performance.
5. If the requirement for an immediate climb is not present, allow the airplane to accelerate to the single engine best rate-of-climb speed since this speed will always provide the best chance of climb or least altitude loss.

## **SINGLE ENGINE CRUISE**

Losing one engine during cruise on a multi-engine airplane causes little immediate problem for a proficient, properly trained pilot. After advancing power on the operating engine and retrimming the airplane to maintain altitude, if possible the pilot should attempt to determine if the cause of the engine failure can be corrected in flight prior to feathering the propeller. The magneto/ignition switches should be checked to see if they are on, and the fuel flow and fuel quantity for the

affected engine should also be verified. If the engine failure was apparently caused by fuel starvation, switching to another fuel tank and/or turning on the auxiliary fuel pump (if equipped) or adjusting the mixture control may alleviate the condition. It must be emphasized that these procedures are not designed to replace the procedural steps listed in the emergency procedures section of the airplane operating handbook, but are presented as a guide to be used by the pilot if, in his or her judgment, corrective action should be attempted prior to shutting down a failing or malfunctioning engine. Altitude, terrain, weather conditions, weight, and accessibility of suitable landing areas must all be considered before attempting to determine and/or correct the cause of an engine failure. In any event, if an engine fails in cruise and cannot be restarted, a landing at the nearest suitable airport is recommended.

## **SINGLE ENGINE APPROACH AND LANDING OR GO-AROUND**

An approach and landing with one engine inoperative on a multi-engine airplane can easily be completed by a proficient, properly trained pilot. However, the pilot must plan and prepare the airplane much earlier than normal to ensure success. While preparing, fuel should be scheduled so that an adequate amount is available for use by the operative engine. All cross feeding should be completed during level flight above a minimum altitude of 1000 feet AGL.

During final approach, the pilot should maintain the single engine best rate-of-climb speed or higher, until the landing is assured. An attempt should be made to keep the approach as normal as possible, considering the situation. Landing gear should be extended on downwind leg or over the final approach fix, as applicable. Flaps should be used to control the descent through the approach.

Consideration should be given to a loss of the other engine or the necessity to make an engine inoperative go-around. Under certain combinations of weight, temperature and altitude, neither level flight nor a single engine go-around may be possible. Do not attempt an engine inoperative go-around after the wing flaps have been extended beyond the normal approach or the published approach flap setting, unless enough altitude is available to allow the wing flaps to be retracted to the normal approach or the published approach flap setting, or less.

## PILOT PROFICIENCY

---

### AIRSPEED CONTROL

Flying other than published airspeeds could put the pilot and airplane in an unsafe situation. The airspeeds published in the airplane's operating handbook have been tested and proven to help prevent unusual situations. For example, proper liftoff speed puts the airplane in the best position for a smooth transition to a climb attitude. However, if liftoff is too early, drag increases and consequently increases the takeoff ground run. This procedure also degrades controllability of multi-engine airplanes in the event an engine failure occurs after takeoff. In addition, early liftoff increases the time required to accelerate from liftoff to either the single-engine best rate-of-climb speed ( $V_{YSE}$ ) or the single-engine best angle-of-climb speed ( $V_{XSE}$ ) if an obstacle is ahead. On the other hand, if liftoff is late, the airplane will tend to "leap" into the climb. Pilots should adhere to the published liftoff or takeoff speed for their particular airplane.

The pilot should be familiar with the stall characteristics of the airplane when stalled from a normal 1 G stall. Any airplane can be stalled at any speed. The absolute maximum speed at which full aerodynamic control can be safely applied is listed in the airplane's operating handbook as the maneuvering speed. Do not make full or abrupt control movements above this speed. To do so could induce structural damage to the airplane.

### TRAFFIC PATTERN MANEUVERS

There have been incidents in the vicinity of controlled airports that were caused primarily by pilots executing unexpected maneuvers. Air Traffic Control (ATC) service is based upon observed or known traffic and airport conditions. Air Traffic Controllers establish the sequence of arriving and departing airplanes by advising them to adjust their flight as necessary to achieve proper spacing. These adjustments can only be based on observed traffic, accurate pilot radio reports, and anticipated airplane maneuvers. Pilots are expected to cooperate so as to preclude disruption of the traffic flow or the creation of conflicting traffic patterns. The pilot in command of an airplane is directly responsible for and is the final authority as to the operation of his or her airplane. On occasion, it may be necessary for a pilot to maneuver an airplane to maintain spacing with the traffic he or she has been sequenced to follow. The controller can anticipate minor maneuvering such as shallow "S" turns. The controller cannot, however, anticipate a major maneuver such as a 360-degree turn. This can result in a gap in the landing interval and more importantly, it causes a chain reaction which may result in a conflict with other traffic and an interruption of the sequence established by the tower or approach controller. The pilot

should always advise the controller of the need to make any maneuvering turns.

## **USE OF LIGHTS**

Aircraft position (navigation) and anti-collision lights are required to be illuminated on aircraft operated at night. Anti-collision lights, however, may be turned off when the pilot in command determines that, because of operating conditions, it would be in the interest of safety to do so. For example, strobe lights should be turned off on the ground when they adversely affect ground personnel or other pilots, and in flight when there are adverse reflections from clouds.

To enhance the "see-and-avoid" concept, pilots are encouraged to turn on their rotation beacon any time the engine(s) are operating, day or night. Pilots are further encouraged to turn on their landing lights when operating within ten miles of any airport, day or night, in conditions of reduced visibility and areas where flocks of birds may be expected (i.e., coastal areas, around refuse dumps, etc.). Although turning on airplane lights does enhance the "see-and-avoid" concept, pilots should not become complacent about keeping a sharp lookout for other airplanes. Not all airplanes are equipped with lights and some pilots may not have their lights turned on. Use of the taxi light, in lieu of the landing light, on some smaller airplanes may extend the landing light service life.

Propeller and jet blast forces generated by large airplanes have overturned or damaged several smaller airplanes taxiing behind them. To avoid similar results, and in the interest of preventing upsets and injuries to ground personnel from such forces, the FAA recommends that air carriers and commercial operators turn on their rotating beacons anytime their airplane engine(s) are operating. All other pilots, using airplanes equipped with rotating beacons, are also encouraged to participate in this program which is designed to alert others to the potential hazard. Since this is a voluntary program, exercise caution and do not rely solely on the rotating beacon as an indication that airplane engines are operating.

## **PARTIAL PANEL FLYING**

All pilots, and especially instrument rated pilots, should know the emergency procedures for partial instrument panel operation included in their respective operating handbook, as well as any FAA training material on the subject. Routine periodic practice under simulated instrument conditions with a partial instrument panel can be very beneficial to a pilot's proficiency. In this case, the pilot should have a qualified safety pilot monitoring the simulated instrument practice.

If a second vacuum system is not installed and a complete vacuum system failure occurs during flight, the vacuum-driven directional indicator and the attitude indicator will be disabled, and the pilot will have to control the airplane by reference to the turn coordinator or the

turn and bank indicator, the magnetic compass and pitot-static instruments, if he or she flies into instrument meteorological conditions. If an autopilot is installed, it too will be affected, and should not be used. The following instructions assume that only the electrically-powered turn coordinator is operative and that the pilot is not completely proficient in instrument flying.

### **EXECUTING A 180° TURN IN CLOUDS**

Upon inadvertently entering a cloud(s), an immediate plan should be made to turn back as follows:

1. Note compass heading.
2. Note the time in both minutes and seconds.
3. When the seconds indicate the nearest half-minute, initiate a standard rate left turn, holding the turn coordinator (or turn and bank indicator if installed) symbolic airplane wing opposite the lower left wing index mark for 60 seconds. Then roll back to level flight by leveling the miniature airplane.
4. Assure level flight through and after the turn by referencing the altimeter, VSI, and airspeed indicator. Altitude may be maintained with cautious use of the elevator controls.
5. Check accuracy of turn by observing the compass heading which should be the reciprocal of the original heading.
6. If necessary, adjust heading primarily with skidding motions rather than rolling motions so that the compass will read more accurately.
7. Maintain altitude and airspeed by cautious application of elevator control. Avoid over-controlling by keeping the hands off the control wheel as much as possible and steering only with the rudder.

### **EMERGENCY DESCENT THROUGH CLOUDS**

If conditions preclude reestablishment of VFR flight by a 180° turn, a descent through a cloud deck to VFR conditions may be appropriate. If possible, obtain ATC clearance for an emergency descent. To guard against a spiral dive, choose an easterly or westerly heading to minimize compass card swings due to changing bank angles. In addition, keep hands off the control wheel and steer a straight course with rudder control by monitoring the turn and bank or turn coordinator. Occasionally check the compass heading and make minor corrections to hold an approximate course. Before descending into the clouds, set up a stabilized let-down condition as follows:

1. Extend the landing gear (if applicable).
2. Reduce power to set up a 500 to 800 ft/min rate of descent.
3. Adjust mixture(s) as required for smooth engine operation.

4. Adjust elevator or stabilizer, rudder and aileron trim controls for a stabilized descent.
5. Keep hands off the control wheel. Monitor turn and bank or turn coordinator and make corrections by rudder alone.
6. Check trend of compass card movement and make cautious corrections with rudder inputs to stop turn.
7. Upon breaking out of the clouds, resume normal cruising flight.

### **RECOVERY FROM A SPIRAL DIVE**

If a spiral dive is encountered while in the clouds, proceed as follows:

1. Retard the throttle(s) to idle.
2. Stop the turn by using coordinated aileron and rudder control to align the symbolic airplane in the turn coordinator with the horizontal reference line, or center the turn needle and ball of the turn and bank indicator.
  - a. With a significant airspeed increase or altitude loss while in the spiral, anticipate that the aircraft will pitch nose-up when the wings are level. Take care not to over stress the airframe as a result of this nose-up pitching tendency.
3. Cautiously apply control wheel back pressure (if necessary) to slowly reduce the airspeed.
4. Adjust the elevator or stabilizer trim control to maintain a constant glide airspeed.
5. Keep hands off the control wheel, using rudder control to hold a straight heading. Use rudder trim to relieve unbalanced rudder force, if present.
6. If the power-off glide is of sufficient duration, adjust the mixture(s), as required.
7. Upon breaking out of the clouds, resume normal cruising flight.

### **USE OF LANDING GEAR AND FLAPS**

A review of airplane accident investigation reports indicates a complacent attitude on the part of some pilots toward the use of checklists for landing gear and wing flap operation. The main confession of most pilots involved in involuntary gear-up landings is that they "forgot" to lower the gear prior to landing. Consistent use of the Before Landing Checklist would have alerted these pilots and prevented a potentially hazardous situation. Other causes of gear-up landings have been attributed to poor judgment, such as not leaving the landing gear extended while performing several landings while remaining in the traffic pattern. The following recommendations will lessen the possibility of a gear-up landing.

1. Never move the landing gear control switch, handle, or lever while the airplane is on the ground.

2. Do not deliberately disable any landing gear warning device or light unless indicated otherwise in the operating handbook.
3. Apply brakes before retraction of the landing gear to stop wheel rotation.
4. After takeoff, do not retract the landing gear until a positive rate of climb is indicated.
5. When selecting a landing gear position, whether up or down, allow the landing gear to complete the initial cycle to the locked position before moving the control switch, handle, or lever in the opposite direction.
6. Never exceed the published landing gear operating speed ( $V_{LO}$ ) while the landing gear is in transit or the maximum landing gear extended speed ( $V_{LE}$ ).
7. Prepare for landing early in the approach so that trim adjustments after lowering landing gear or flaps will not compromise the approach.
8. Leave landing gear extended during consecutive landings when the airplane remains in the traffic pattern unless traffic pattern speeds exceed the Maximum Landing Gear Extended Speed ( $V_{LE}$ ).

A rare, but serious problem that may result from a mechanical failure in the flap system is split wing flaps. This phenomenon occurs when the wing flap position on one wing does not agree with the flap position on the opposite wing, causing a rolling tendency. Split flaps can be detected and safely countered if flap control movement is limited to small increments during inflight operations from full down to full up and full up to full down. If a roll is detected during flap selection, reposition the flap selector to the position from which it was moved and the roll should be eliminated. Depending on the experience and proficiency of the pilot, the rolling tendencies caused by a split flap situation may be controlled with opposite aileron (and differential power for multi-engine aircraft). Some documented contributing factors to split flaps are:

1. Pilots exceeding the Maximum Flap Extended ( $V_{FE}$ ) speed for a given flap setting.
2. Mechanical failure.
3. Improper maintenance.

## ILLUSIONS IN FLIGHT

Many different illusions can be experienced in flight. Some can lead to spatial disorientation (See related information in following pages). Others can lead to landing errors. Illusions rank among the most common factors cited as contributing to fatal airplane accidents.

Various complex motions and forces and certain visual scenes encountered in flight can create illusions of motion and position when visual references deteriorate, and the pilot is not trained to rely and fly

by reference to the flight instruments. Spatial disorientation from these illusions can be prevented by learning to rely on the flight instruments, disregard sensory information and only use reliable visual references.

An abrupt correction of banked attitude, which has been entered too slowly to stimulate the motion sensing system in the middle ear, can create the illusion of banking in the opposite direction. The disoriented pilot will roll the airplane back to its original dangerous attitude or, if level flight is maintained, will feel compelled to lean in the perceived vertical plane until this illusion subsides. This phenomenon is usually referred to as the "leans" and the following illusions fall under this category.

1. **Coriolis illusion** - An abrupt head movement in a prolonged constant-rate turn that has ceased stimulating the motion sensing system can create the illusion of rotation or movement on an entirely different axis. The disoriented pilot will maneuver the airplane into a dangerous attitude in an attempt to stop this illusion of rotation. This most overwhelming of all illusions in flight may be prevented by not making sudden, extreme head movements, particularly while making prolonged constant-rate turns under IFR conditions.
2. **Graveyard spin** - A proper recovery from a spin that has ceased stimulating the motion sensing system can create the illusion of spinning in the opposite direction. The disoriented pilot will return the airplane to its original spin.
3. **Graveyard spiral** - An observed loss of altitude during a coordinated constant-rate turn that has ceased stimulating the motion sensing system can create the illusion of being in a descent with the wings level. In this case, the disoriented pilot will pull back on the controls, tightening the spiral and increasing the normal load factor on the airplane.
4. **Somatogravic illusion** - A rapid acceleration during takeoff can create the illusion of being in a nose up attitude. The disoriented pilot will push the airplane into a nose low, or dive attitude. A rapid deceleration by a quick reduction of the throttle(s) can have the opposite effect, with the disoriented pilot pulling the airplane into a nose up, or stall attitude.
5. **Inversion illusion** - An abrupt change from climb to straight and level flight can create the illusion of tumbling backwards. The disoriented pilot will push the airplane abruptly into a nose low attitude, possibly intensifying this illusion.
6. **Elevator illusion** - An abrupt upward vertical acceleration, usually caused by an updraft, can create the illusion of being in a climb. The disoriented pilot will push the airplane into a nose low attitude. An abrupt downward vertical acceleration, usually caused by a downdraft, has the opposite effect, with the disoriented pilot pulling the airplane into a nose up attitude.

7. **False horizon** - Sloping cloud formations, an obscured horizon, a dark scene spread with ground lights and stars, and certain geometric patterns of ground light can create illusions of not being aligned correctly with the horizon. The disoriented pilot will place the airplane in a dangerous attitude.
8. **Autokinesis** - In the dark, a static light will appear to move about when stared at for many seconds. The disoriented pilot will lose control of the airplane in attempting to align it with the light.

Various surface features and atmospheric conditions encountered during landing can create illusions of incorrect height above and distance away from the runway threshold. Landing errors from these illusions can be prevented by: anticipating them during approaches, aerial visual inspection of unfamiliar airports before landing, using an electronic glide slope or visual approach slope indicator (VASI) system when available, and maintaining optimum proficiency in landing procedures. The following illusions apply to this category.

1. **Runway width illusion** - A narrower than usual runway can create the illusion that the airplane is at a higher altitude than it actually is. The pilot who does not recognize this illusion will tend to fly a lower approach, with the risk of striking objects along the approach path, or land short. A wider than usual runway can have the opposite effect, with the risk of flaring high and landing hard or overshooting the runway.
2. **Runway and terrain slopes illusion** - An up sloping runway, up sloping terrain, or both, can create the illusion that the airplane is at a higher altitude than it actually is. The pilot who does not recognize this illusion will fly a lower approach. A down sloping runway, down sloping approach terrain, or both, can have the opposite effect.
3. **Featureless terrain illusion** - An absence of ground features, as when landing over water, darkened areas and terrain made featureless by snow, can create the illusion that the airplane is at a higher altitude than it actually is. The pilot who does not recognize this illusion will tend to fly a lower approach.
4. **Atmospheric illusion** - Rain on the windshield can create an illusion of greater height, and a greater distance from the runway. The pilot who does not recognize this illusion will tend to fly a lower approach. Penetration of fog can create the illusion of pitching up. The pilot who does not recognize this illusion will steepen the approach, often quite abruptly.

5. **Ground lighting illusions** - Lights along a straight path, such as a road, and even lights on trains, can be mistaken for runway and approach lights. Bright runway and approach lighting systems, especially where few lights illuminate the surrounding terrain, may create the illusion of less distance to the runway. The pilot who does not recognize this illusion will tend to fly a higher approach. Conversely, the pilot overflying terrain which has few lights to provide height clues may make a lower than normal approach.

## **SPATIAL DISORIENTATION**

Spatial disorientation is the confusion of the senses affecting balance, which occurs when a person is deprived of the normal clues upon which he or she depends for "indexing" a sense of balance. Loss of control can result from the pilot unable to understand what the airplane is doing. These clues include, most prominently, his or her visual reference to the earth's horizon and celestial bodies, and his or her acceptance of the force of gravity as acting vertically. When flying an airplane, the pilot may have all outside visual references obscured by clouds or complete darkness, and his interpretation of the direction of gravity may become confused by forces imposed on his or her body by centrifugal force, accelerations of maneuvering, and turbulence, which may act in any direction.

Spatial disorientation usually leads to vertigo, but is not necessarily identical to it. Vertigo is an uncertain feeling of disorientation, turning, or imbalance, which is usually accompanied by feelings of dizziness or incipient nausea.

During instrument flight, the attitude of the airplane must be determined from the gyro horizon ("attitude indicator") with cross-reference to other flight instruments.

Sometimes during conditions of low visibility, the supporting senses conflict with what is seen or what the pilot believes he sees. When this happens, there is a definite susceptibility to disorientation. The degree of disorientation varies considerably with individual pilots, their proficiency, and the conditions which induced the problem. Complete disorientation, even for a short period of time, can render a pilot incapable of controlling an airplane, to the extent that he cannot maintain level flight, or even prevent fatal turns and diving spirals.

Lack of effective visual reference is common on over-water flights at night, and in low visibility conditions over land. Other contributing factors to disorientation and vertigo are reflections from outside lights, and cloud reflections of beams from rotating beacons or strobe lights.

It is important that all pilots understand the possibility of spatial disorientation, and the steps necessary to minimize the loss of control as a result of it. The following basic items should be known to every pilot:

1. Obtain training and maintain proficiency in the control of an airplane by reference to instruments before flying in visibility of less than three miles.
2. Refer to the attitude instruments frequently when flying at night or in reduced visibility conditions.
3. To maintain competency in night operations, practice should include operations in the traffic pattern, subject to the confusion caused by reflections of ground lights, as well as the control of an airplane by reference to instruments.
4. Familiarization with the meteorological conditions which may lead to spatial disorientation is important. These include smoke, fog, haze, and other restrictions to visibility.
5. Familiarity with local areas and commonly used flight routes assists in the avoidance of disorientation by permitting the pilot to anticipate and look for prominent terrain features.
6. The most important precaution for avoiding disorientation is the habit of thoroughly checking the weather before each flight, while enroute, and near the destination.

A pilot without the demonstrated competence to control an airplane by sole reference to instruments has little chance of surviving an unintentional flight into IFR conditions. Tests conducted by the U.S. Air Force, using qualified instrument pilots, indicate that it may take as long as 35 seconds to establish full control by reference to instruments after disorientation during an attempt to maintain VFR flight in IFR weather. Instrument training and certification and ongoing recurrent training in accordance with FAR Part 61, are designed to provide the pilot with the skills needed to maintain control solely by reference to flight instruments and the ability to ignore the false kinesthetic sensations inherent with flight when no outside references are available.

## **MOUNTAIN FLYING**

A pilot's first experience of flying over mountainous terrain (particularly if most of his or her flight time has been over flatlands) could be a never-to-be-forgotten experience if proper planning is not done and if the pilot is not aware of potential hazards. Those familiar section lines in some regions are not present in the mountains. Flat, level fields for forced landings are practically nonexistent; abrupt changes in wind direction and velocity may occur; severe updrafts and downdrafts are common during high wind conditions, particularly near or above abrupt changes of terrain, such as cliffs or rugged areas; and clouds can build up with startling rapidity. Mountain flying need not be hazardous if you follow the recommendations below:

1. For pilots with little or no mountain flying experience, always get dual instruction from a qualified flight instructor to become familiar with conditions which may be encountered before flying in mountainous terrain.
2. Plan your route to avoid topography which would prevent a safe forced landing. The route should be near populated areas and well known mountain passes. Sufficient altitude should be maintained to permit gliding to a safe landing in the event of engine failure.
3. Always file a flight plan.
4. Don't fly a light airplane when the winds aloft, at your proposed altitude, exceed 35 miles per hour. Expect the winds to be of much greater velocity over mountain passes than reported a few miles from them. Approach mountain passes with as much altitude as possible. Downdrafts of from 1500 to 2000 feet per minute are not uncommon on the leeward (downwind) side.
5. Severe turbulence can be expected near or above changes in terrain, especially in high wind conditions.
6. Some canyons run into a dead end. Don't fly so far into a canyon that you get trapped. Always be able to make a 180-degree turn, or if canyon flying is necessary, fly down the canyon (toward lower terrain), not up the canyon (toward higher terrain).
7. Plan the trip for the early morning hours. As a rule, the air starts to get turbulent at about 10 a.m., and grows steadily worse until around 4 p.m., then gradually improves until dark.
8. When landing at a high altitude airfield, the same indicated airspeed should be used as at low elevation fields. Due to the less dense air at altitude, this same indicated airspeed actually results in a higher true airspeed, a faster landing speed, and a longer landing distance. During gusty wind conditions, which often prevail at high altitude fields, a "power approach" is recommended. Additionally; due to the faster ground speed and reduced engine performance at altitude, the takeoff distance will increase considerably over that required at lower altitudes.

## **OBSTRUCTIONS TO FLIGHT**

Pilots should exercise extreme caution when flying less than 2000 feet above ground level (AGL) because of the numerous structures (radio and television antenna towers) exceeding 1000 feet AGL, with some extending higher than 2000 feet AGL. Most truss type structures are supported by guy wires. The wires are difficult to see in good weather and can be totally obscured during periods of dusk and reduced visibility. These wires can extend approximately 1500 feet horizontally from a structure; therefore, all truss type structures should be avoided by at least 2000 feet, horizontally and vertically.

Overhead transmission and utility lines often span approaches to runways and scenic flyways such as lakes, rivers, and canyons. The supporting structures of these lines may not always be readily visible and the wires may be virtually invisible under certain conditions. Most of these installations do not meet criteria which determine them to be obstructions to air navigation and therefore, do not require marking and/or lighting. The supporting structures of some overhead transmission lines are equipped with flashing strobe lights. These lights indicate wires exist between the strobe equipped structures.



## **FUEL MANAGEMENT**

---

### **POOR TECHNIQUES**

Poor fuel management is often the cause of aircraft accidents. Some airplane accident reports have listed such poor fuel management techniques as switching to another fuel tank after the before takeoff runup was completed, and then experiencing engine problems on takeoff. Other reports tell of pilots switching fuel tanks at a critical point on the approach to a landing and inadvertently selecting an empty tank when there is not enough time to compensate for the subsequent loss of power. Flying low during day crosscountry, or moderately low at night, can be hazardous if a fuel tank runs dry. Too much altitude may be lost during the time it takes to discover the reason for power loss, select a different fuel tank, and restart the engine. Pilots should be thoroughly familiar with the airplane fuel system and tank switching procedures. Furthermore, it is an unsafe technique to run a fuel tank dry as a routine procedure, although there are exceptions. Any sediment or water not drained from the fuel tank could be drawn into the fuel system and cause erratic operation or even total power loss.

### **FUELING THE AIRCRAFT**

The aircraft should be on level ground during all fueling operations, since filling the tanks when the aircraft is not level may result in a fuel quantity less than the maximum capacity. Rapid filling of a fuel tank, without allowing time for air in the tank to escape, may result in a lower fuel quantity. Some single engine aircraft that allow simultaneous use of fuel from more than one tank have fuel tanks with interconnected vent lines. If the tanks are filled with fuel and the aircraft allowed to sit with one wing lower than the other, fuel may drain from the higher tank to the lower and subsequently out the fuel vent. This will result in loss of fuel. This fuel loss may be prevented by placing the fuel selector in a position other than "both".

Some Cessna single-engine airplanes have long, narrow fuel tanks. If your airplane is so equipped, it may be necessary to partially fill each tank alternately, and repeat the sequence as required to completely fill the tanks to their maximum capacity. This method of fueling helps prevent the airplane from settling to a wing-low attitude because of increased fuel weight in the fullest wing tank.

It is always the responsibility of the pilot-in-command to ensure sufficient fuel is available for the planned flight. Refer to the airplane operating handbook for proper fueling procedures.

## UNUSABLE FUEL

Unusable fuel is the quantity of fuel that cannot safely be used in flight. The amount of unusable fuel varies with airplane and fuel system design, and the maximum amount is determined in accordance with Civil or Federal Aviation Regulations (CARs or FARs). Unusable fuel is always included in the airplane's licensed or basic empty weight for weight and balance purposes. Unusable fuel should never be included when computing the endurance of any airplane.

## FUEL PLANNING WITH MINIMUM RESERVES

Airplane accidents involving engine power loss continue to reflect fuel starvation as the primary cause or a contributing factor. Some of these accidents were caused by departing with insufficient fuel onboard to complete the intended flight. Fuel exhaustion in flight can mean only one thing - a forced landing with the possibility of serious damage, injury, or death.

A pilot should not begin a flight without determining the fuel required and verifying its presence onboard. To be specific, during VFR conditions, do not take off unless there is enough fuel to fly to the planned destination (considering wind and forecast weather conditions), assuming the airplane's normal cruising airspeed, fly after that for at least 30 minutes during the day, or at least 45 minutes at night.

Departure fuel requirements are a little different when operating under IFR conditions. Do not depart an airport on an IFR trip unless the airplane has enough fuel to complete the flight to the first airport of intended landing (considering weather reports and forecasts) and fly from that airport to the planned alternate airport, and afterwards still fly at least 45 minutes at normal cruising speed.

## FLIGHT COORDINATION VS. FUEL FLOW

The shape of most airplane wing fuel tanks is such that, in certain flight maneuvers, the fuel may move away from the fuel tank supply outlet. If the outlet is uncovered, fuel flow to the engine may be interrupted and a temporary loss of power might result. Pilots can prevent inadvertent uncovering of the tank outlet by having adequate fuel in the tank selected and avoiding maneuvers such as prolonged uncoordinated flight or sideslips which move fuel away from the feed lines.

It is important to observe the uncoordinated flight or sideslip limitations listed in the respective operating handbook. As a general rule, limit uncoordinated flight or sideslip to 30 seconds in duration when the fuel level in the selected fuel tank is 1/4 full or less. Airplanes are usually considered in a sideslip anytime the turn and bank "ball" is more than one quarter ball out of the center (coordinated flight) position. The amount of usable fuel decreases with the severity of the sideslip in all cases.

## **FUEL SELECTION FOR APPROACH/LANDING**

On some single-engine airplanes, the fuel selector valve handle is normally positioned to the BOTH position to allow symmetric fuel feed from each wing fuel tank. However, if the airplane is not kept in coordinated flight, unequal fuel flow may occur. The resulting wing heaviness may be corrected during flight by turning the fuel selector valve handle to the tank in the "heavy" wing. On other single-engine airplanes, the fuel selector has LEFT ON or RIGHT ON positions, and takeoffs and landings are to be accomplished using fuel from the fuller tank.

Most multi-engine airplanes have fuel tanks in each wing or in wing tip tanks, and it is advisable to feed the engines symmetrically during cruise so that approximately the same amount of fuel will be left in each side for descent, approach, and landing. If fuel has been consumed at uneven rates between the two wing tanks because of prolonged single-engine flight, fuel leak or siphon, or improper fuel servicing, it is desirable to balance the fuel load by operating both engines from the fuller tank. However, as long as there is sufficient fuel in both wing tanks, even though they may have unequal quantities, it is important to switch the left and right fuel selectors to the left and right wing tanks, respectively, feeling for the detent, prior to the approach. This will ensure that adequate fuel flow will be available to each operating engine if a go-around is necessary. In the case of single-engine operation, operate from the fuller tank, attempting to have a little more fuel in the wing on the side with the operating engine prior to descent.

On all multi-engine airplanes equipped with wing tip fuel tanks, the tip tanks are the main fuel tanks on the tank selector valve controls. Refer to Supplement 12 of this Pilot Safety and Warning Supplements Manual and the applicable airplane operating handbook.



## **AIRFRAME ICING**

---

Pilots should monitor weather conditions while flying and should be alert to conditions which might lead to icing. Icing conditions should be avoided when possible, even if the airplane is certified and approved for flight into known icing areas. A climb normally is the best ice avoidance action to take. Alternatives are a course reversal or a descent to warmer air. If icing conditions are encountered inadvertently, immediate corrective action is required.

### **FLIGHT INTO KNOWN ICING**

Flight into known icing is the intentional flight into icing conditions that are known to exist. Icing conditions exist anytime the indicated OAT (outside air temperature) is +10°C or below, or the RAT (ram air temperature) is +10°C or below, and visible moisture in any form is present. Any airplane that is not specifically certified for flight into known icing conditions, is prohibited by regulations from doing so.

Ice accumulations significantly alter the shape of the airfoil and increase the weight of the aircraft. Ice accumulations on the aircraft will increase stall speeds and alter the speeds for optimum performance. Flight at high angles of attack (low airspeed) can result in ice buildup on the underside of wings and the horizontal tail aft of the areas protected by boots or leading edge anti-ice systems. Trace or light amounts of icing on the horizontal tail can significantly alter airfoil characteristics, which will affect stability and control of the aircraft.

Inflight ice protection equipment is not designed to remove ice, snow, or frost accumulations on a parked airplane sufficiently enough to ensure a safe takeoff or subsequent flight. Other means (such as a heated hangar or approved deicing solutions) must be employed to ensure that all wing, tail, control, propeller, windshield, static port surfaces and fuel vents are free of ice, snow, and frost accumulations, and that there are no internal accumulations of ice or debris in the control surfaces, engine intakes, brakes, pitot-static system ports, and fuel vents prior to takeoff.

### **AIRPLANES CERTIFIED FOR FLIGHT INTO KNOWN ICING**

An airplane certified for flight into known icing conditions must have all required FAA approved equipment installed and fully operational. Certain airplanes have a flight into known icing equipment package available which, if installed in its entirety and completely operational, allows intentional penetration of areas of known icing conditions as reported in weather sequences or by PIREPS.

This known icing package is designed specifically for the airplane to provide adequate in-flight protection during normally encountered icing conditions produced by moisture-laden clouds. It will not provide total protection under severe conditions such as those which exist in areas of freezing rain, nor will it necessarily provide complete protection for continuous operation in extremely widespread areas of heavy cloud moisture content. The installed equipment should be used to protect the airplane from ice while seeking a different altitude or routing where ice does not exist. During all operations, the pilot must exercise good judgment and be prepared to alter his flight if conditions exceed the capacity of the ice protection equipment or if any component of this equipment fails.

The airplane's operating handbook will indicate the required equipment for intentional flight into known icing conditions. Such equipment may include: wing leading edge deice/anti-ice system, vertical and horizontal stabilizer leading edge deice/anti-ice system, propeller deice/anti-ice system, windshield anti-ice, heated pitot tube, heated static ports and fuel vents, heated stall warning vane/transducer or optional angle-of-attack lift sensor vane, ice detector light(s), and increased capacity electrical and vacuum systems.

If there is any doubt whether the airplane is certified or has all the required equipment, the pilot should assume that the airplane is not certified for flight into known icing and avoid any encounters with areas of icing.

## **KINDS OF ICING**

Airframe icing is a major hazard. It is at its worst when the supercooled (liquid below freezing temperature) water droplets are large and plentiful. Droplets of this type are usually found in cumulus clouds and are the cause of "clear ice". Clear ice is transparent ice deposited in layers, and may be either smooth or rough. This ice coats more of the wing than "rime ice" because the droplets flow back from the leading edge over the upper and lower wing surface before freezing, and the rate of accumulation is higher.

Rime ice is an opaque, granular, and rough deposit of ice that is usually encountered in stratus clouds. Small supercooled droplets freeze instantly when struck by the leading edges of the airplane. Rime ice can quickly change the drag characteristics of the airplane. Under some conditions, a large "double horn" buildup on the leading edges can occur which drastically alters the airfoil shape. Altitude changes usually work well as an avoidance strategy for rime ice. In colder temperatures, these types of supercooled water droplets quickly convert to ice crystals.

Icing in precipitation comes from freezing rain or drizzle which falls from warmer air aloft to colder air below. This results in a very rapid buildup of clear ice, and must be avoided by all means available to the pilot.

If it is snowing, the problem is not so much the snow sticking to the airplane as the icing caused by the supercooled water droplets in the clouds from which the snow is falling. The amount of ice will depend upon cloud saturation.

Pilots should report all icing conditions to ATC/FSS, and if operating under IFR conditions, request new routing or altitude if icing will be a hazard. Be sure to give type of airplane when reporting icing. The following describe how to report icing conditions:

1. **Trace** - Ice becomes visible. Rate of accumulation is slightly greater than the rate of sublimation. Anti-ice equipment must be on and deice equipment may or may not be required.
2. **Light** - The rate of accumulation may create a problem if flight is prolonged in this environment (over 1 hour). Occasional use of deicing equipment and continuous use of anti-icing equipment removes/prevents accumulation.
3. **Moderate** - The rate of accumulation is such that even short encounters become potentially hazardous and use of deicing/anti-icing equipment and flight diversion is necessary.
4. **Severe** - The rate of accumulation is such that deicing/anti-icing equipment fails to reduce or control the hazard. Immediate flight diversion is necessary.

## RESULTS OF ICING

Airplane performance can be severely reduced by ice accumulation. Accumulation of 1/2 inch of ice on the leading edges of the wings and empennage can cause a large loss in rate of climb, a cruise speed reduction of up to 30 KIAS, as well as a significant buffet and stall speed increase. Even if the airplane is certified for flight into known icing and the equipment is working properly, ice remaining on unprotected areas of the airplane can cause large performance losses. With one inch of residual ice accumulation, these losses can double, or even triple. Ice accumulation also will increase airplane weight.

## INADVERTENT ICING ENCOUNTER

Flight into icing conditions is not recommended. However, an inadvertent encounter with these conditions is possible. The following are things to consider doing if inadvertent icing is experienced. These items are not intended to replace procedures described in any operating handbook. Instead, this list has been generated to familiarize pilots of older model Cessnas with guidelines they can use in the event of an inadvertent icing condition. The best procedure is a change of altitude, or course reversal to escape the icing conditions.

1. Turn pitot heat, stall warning heat, propeller deice/anti-ice, and windshield anti-ice switches ON (if installed).
2. Change altitude (usually climb) or turn back to obtain an outside air temperature that is less conducive to icing.
3. Increase power as necessary to maintain cruise airspeed and to minimize ice accumulation. Maintain a minimum indicated airspeed of  $V_Y + 10$  KIAS until assured that all ice is off the airframe.
4. Turn cabin heat and defroster controls full on and open defrost control to obtain maximum windshield defroster effectiveness.
5. Increase engine speed to minimize ice buildup on propeller blades. If excessive vibration is noted, momentarily reduce engine speed with the propeller control, and then rapidly move the control full forward. Cycling the RPM flexes the propeller blades and high RPM increases centrifugal force, causing ice to shed more readily.
6. Watch for signs of induction air filter ice. Regain manifold pressure by increasing the throttle setting and/or selecting alternate air or carburetor heat. If ice accumulates on the intake filter (requiring alternate air), a decrease of manifold pressure will be experienced, and the mixture should be adjusted as required.
7. If icing conditions are unavoidable, plan a landing at the nearest airport. In the event of an extremely rapid ice buildup, select a suitable "off airport" landing site.
8. Ice accumulation of 1/4 inch or more on the wing leading edges may require significantly higher power and a higher approach and landing speed, and result in a higher stall speed and longer landing roll.
9. If practical, open the window and scrape ice from a portion of the windshield for visibility in the landing approach.
10. Approach with reduced flap extension to ensure adequate elevator effectiveness in the approach and landing.
11. Avoid a slow and high flare-out.
12. Missed approaches should be avoided whenever possible, because of severely reduced climb capability. However, if a go-around is mandatory, make the decision much earlier in the approach than normal. Apply maximum power while retracting the flaps slowly in small increments (if extended). Retract the landing gear after immediate obstacles are cleared.

## **WEATHER**

---

### **ALERTNESS**

Most pilots pay particularly close attention to the business of flying when they are intentionally operating in instrument weather conditions. On the other hand, unlimited visibility tends to encourage a sense of security which may not be justified. The pilot should be alert to the potential of weather hazards, and prepared if these hazards are encountered on every flight.

### **VFR JUDGMENT**

Published distance from clouds and visibility regulations establish the minimums for VFR flight. The pilot who uses even greater margins exercises good judgment. VFR operation in class D airspace, when the official visibility is 3 miles or greater, is not prohibited, but good judgment would dictate that VFR pilots keep out of the approach area under marginal conditions.

Precipitation reduces forward visibility. Although it is perfectly legal to cancel an IFR flight plan whenever the pilot feels he can proceed VFR, it is usually a good practice to continue IFR into a terminal area until the destination airport is in sight.

While conducting simulated instrument flights, pilots should ensure that the weather provides adequate visibility to the safety pilot. Greater visibility is advisable when flying in or near a busy airway or close to an airport.

### **IFR JUDGMENT**

The following tips are not necessarily based on Federal Aviation Regulations, but are offered as recommendations for pilot consideration. They do, however, address those elements of IFR flight that are common causes of accidents.

1. All pilots should have an annual IFR proficiency check, regardless of IFR hours flown.
2. For the first 25 hours of pilot-in-command time in airplane type, increase ILS visibility minimums and raise nonprecision approach minimums.
3. An operating autopilot or wing leveler is strongly recommended for single pilot IFR operations.
4. Do not depart on an IFR flight without an independent power source for attitude and heading systems, and an emergency power source for at least one VHF communications radio, or a hand-held communications radio.

5. Be sure the airplane has enough fuel to fly to the destination with a headwind calculated at 125 percent of the forecast wind, and a tailwind calculated at 75 percent of forecast wind. Also, include enough fuel to miss the approach at the destination airport, climb to cruise altitude and fly an approach at an alternate airport, plus 45 minutes of fuel for low altitude holding.
6. The IFR takeoff runway should meet the criteria of the accelerate-stop/go distances for that particular twin-engine airplane, or 200 percent of the distance to clear a 50-foot obstacle for a single.
7. Do not enter an area of embedded thunderstorms without on-board weather detection equipment (radar and/or Stormscope<sup>TM</sup>) and unless cloud bases are at least 2000 feet above the highest terrain, terrain is essentially level, and VFR can be maintained. Avoid all cells by five miles, and severe storms by 20 miles.
8. Do not enter possible icing conditions unless all deice and anti-ice systems are fully operational, or the weather provides at least a 1000 foot ceiling and three miles visibility for the entire route over level terrain, and the surface temperatures are greater than 5°C.
9. Adhere to weather minimums, missed approach procedures and requirements for visual contact with the runway environment. If an approach is missed, with the runway not in sight at the appropriate time because of weather conditions, do not attempt another approach unless there is a valid reason to believe there has been a substantial improvement in the weather.
10. Observe the minimum runway requirement for an IFR landing. The minimum IFR runway length for propeller driven airplanes should be considered 200 percent of maximum landing distance. Increase these distances 90 percent for a wet runway and 150 percent for ice on the runway.
11. Make a missed approach if speed and configuration are not stable inside the middle marker or on nonprecision final, or if the touchdown aiming point will be missed by more than 1000 feet. If an approach is missed because of pilot technique, evaluate the reasons and options before attempting another approach.
12. Use supplemental oxygen above a cabin altitude of 5000 feet at night, and above 10,000 feet during the day.

## WIND

The keys to successfully counteracting the effects of wind are proficiency, understanding the wind response characteristics of the airplane, and a thoughtful approach to the operation. Some operating handbooks indicate a maximum demonstrated crosswind velocity, but this value is not considered to be limiting. There is an ultimate limit on

wind for safe operation, which varies with the airplane and pilot. The lighter the airplane and the lower the stalling speed, the less wind it will take to exceed this limit. The way an airplane rests on its landing gear affects handling characteristics. If it sits nose down, the wing will be unloaded and the airplane will handle better in wind than an airplane which sits in a nose up attitude, creating a positive angle of attack. For the latter type, the full weight of the airplane cannot be on the wheels as the airplane is facing into the wind. Airplanes with these characteristics cause pilots to work harder to keep the airplane under control.

## **CROSSWIND**

While an airplane is moving on the ground, it is affected by the direction and velocity of the wind. When taxiing into the wind, the control effectiveness is increased by the speed of the wind. The tendency of an airplane to weathervane is the greatest while taxiing directly crosswind, which makes this maneuver difficult. When taxiing in crosswind, speed and use of brakes should be held to a minimum and all controls should be utilized to maintain directional control and balance (see Crosswind Taxi Diagram, Figure 1).

Takeoffs into strong crosswinds are normally performed with the minimum flap setting necessary for the field length. With the ailerons deflected into the wind, the airplane should be accelerated to a speed slightly higher than normal (on multi-engine airplanes, additional power may be carried on the upwind engine until the rudder becomes effective), and then the airplane should be flown off abruptly to prevent possible settling back to the runway while drifting. When clear of the ground and any obstacle, the pilot should execute a coordinated turn into the wind to correct for drift. The pilot's ability to handle a crosswind is more dependent upon pilot proficiency than airplane limitations.

A crosswind approach and landing may be performed using either the wing-low, crab, or combination drift correction technique, depending upon the training, experience, and desires of the pilot. Use of the minimum flap setting required for the field length is recommended. Whichever method is used, the pilot should hold a straight course after touchdown with the steerable nose or tailwheel and occasional differential braking, if necessary.

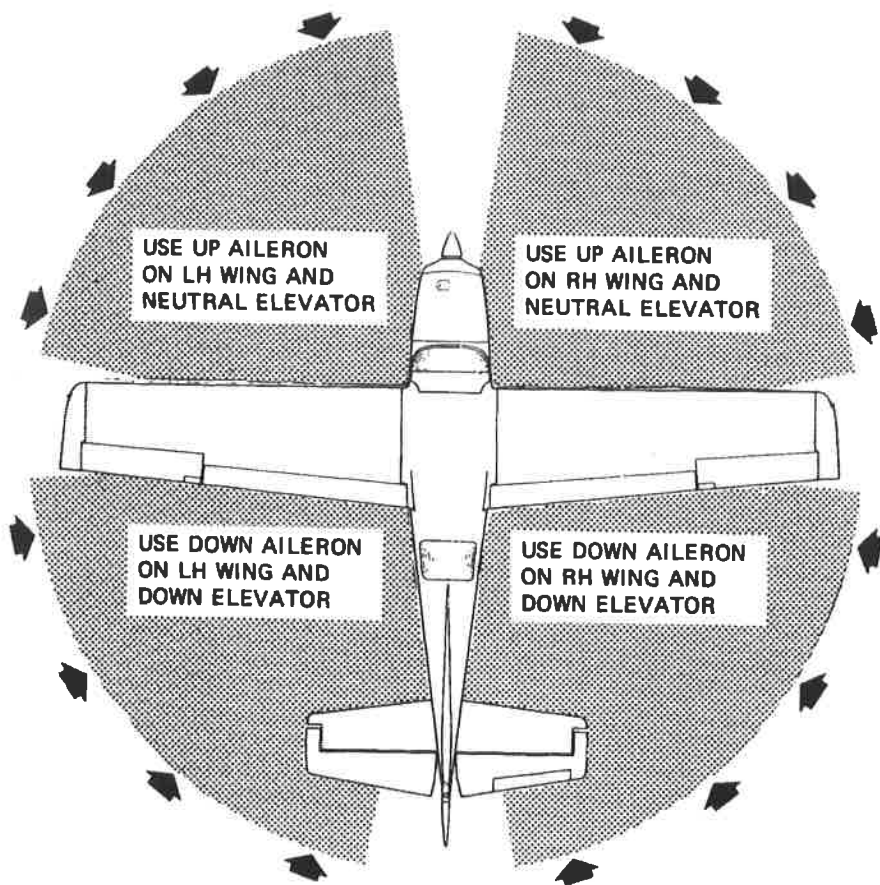

**CODE**

WIND DIRECTION →

**NOTE**

Strong quartering tail winds required caution. Avoid sudden bursts of the throttle and sharp braking when the airplane is in this attitude. Use the steerable nose or tail wheel and rudder to maintain direction.

Figure 1. Crosswind Taxi Diagram

On those airplanes with a steerable tailwheel, landings may be made with the tailwheel lock (if installed) engaged or disengaged. Although the use of the lock is left to the individual pilot's preference, it should be used during strong crosswind landings on rough fields with a heavily loaded airplane. If the lock were disengaged, this condition could lead to a touchdown with a deflected tailwheel and subsequent external forces on the tailwheel that are conducive to shimmy.

## **LOW LEVEL WIND SHEAR**

Low level wind shear is the interflow of air masses near the ground, having different speeds and directions. As an airplane passes through the narrow boundary between the two air masses, large fluctuations in airspeed may be encountered depending on the difference in speed and direction of the air masses. Low level wind shear can be experienced through both the horizontal and vertical plane. One major risk with a wind shear encounter is that a sudden loss of airspeed may render the airplane out of control near the ground. Recovery depends on altitude and the magnitude of the airspeed loss.

A wind shear encounter can be reported as either positive or negative. A positive wind shear is one in which the headwind component suddenly increases. The airplane's inertia makes it tend to maintain the same velocity through space, not through air, so the first thing a pilot is likely to notice is an increase in airspeed. The opposite case, a negative wind shear, is a sudden decrease in headwind component. The airplane will begin to sink immediately, as lift is decreased by the reduced airspeed; and as the natural aerodynamics, and/or the pilot, lowers the nose, the descent rate increases.

The effects of wind shear on smaller airplanes are sometimes less severe than on large jetliners. Smaller airplanes have less mass (and therefore less inertia), and their speed can change more quickly. Thus, a smaller airplane can return to its trimmed speed, after encountering a wind shear, more rapidly than a larger, heavier one.

## **TYPES OF WIND SHEAR CONDITIONS**

Wind shear is encountered in several distinct weather scenarios. Within a frontal zone, as one air mass overtakes another, variations in wind speed and direction can be significant. Fast moving cold fronts, squall lines, and gust fronts pose the highest risk.

A temperature inversion can present a fast moving air mass directly above a very stable calm layer at the surface. Under these conditions an airplane on approach with a headwind aloft will experience a rapid loss of airspeed during descent through the boundary layer to the calm air beneath.

The most violent type of wind shear is that induced by convective activity and thunderstorms. Downdrafts created by local areas of descending air (roughly 5 to 20 miles diameter) can exceed 700 feet per minute. At times, very small areas of descending air (1 mile or so in diameter), called microbursts, can reach vertical speeds of 6000 feet per minute or more. Such downdrafts generate significant turbulence and exceed the climb capability of many airplanes. In addition, as the downdraft/microburst reaches the ground, the air spreads in all directions. The pilot entering the area at relatively low altitude will likely experience an increase in airspeed followed by a dramatic decrease in airspeed and altitude while exiting the area.

## INDICATIONS OF WIND SHEAR

The winds near or around the base of a thunderstorm are largely unpredictable, but there are identifiable signs that may indicate that wind shear conditions exist. Small areas of rainfall, or shafts of heavy rain are clues to possible wind shear conditions. Virga, or rain shafts that evaporate before reaching the ground, may indicate cool, dense air sinking rapidly and may contain microburst winds. On the ground, such signs as trees bending in the wind, ripples on water, or a line of dust clouds should alert the pilot.

With the presence of a strong temperature inversion, if low clouds are moving rapidly but winds are calm or from a different direction on the surface, a narrow wind shear zone might exist and the pilot may elect to use a higher climb speed until crossing the zone. Conversely, while in the landing pattern or on an approach, if the reported surface winds are significantly different than that being experienced in flight, it must be taken as a warning to the potential of wind shear.

A pilot who has been holding a wind correction angle on final approach, and suddenly finds that a change has to be made - i.e., the runway (or CDI needle) starts moving off to the side - most likely encountered wind shear. The usual techniques apply, such as an appropriate heading change, but more importantly, the pilot has been alerted to the presence of a wind shear situation and should be ready to deal with a more serious headwind to tailwind shear at any time.

## COPING WITH WIND SHEAR

A pilot can cope with wind shear by maintaining a somewhat higher airspeed not to exceed  $V_A$  (maneuvering speed), since the conditions conducive to wind shear are also often conducive to turbulence. Pilots should be alert for negative wind shear; if the airspeed is suddenly decreasing, the sink rate increasing, or more than usual approach power is required, a negative wind shear may well have been encountered. Also, the closer the airplane gets to the ground, the smaller the margin for sink recovery.

Be prepared to go around at the first indication of a negative wind shear. A positive wind shear may be followed immediately by a negative shear.

Some larger airports are equipped with a low-level wind shear alerting system (LLWAS). Many have ATIS, and or AWOS wind information. All elements of the weather conditions including pilot reports should be carefully considered and any pilot who experiences wind shear should warn others.

In summary, all pilots should remain alert to the possibility of low level wind shear. If wind shear is encountered on final approach, usually characterized by erratic airspeed and altimeter indications and almost always associated with uncommanded airplane attitude changes, do not hesitate to go around. If the approach profile and airspeed cannot be reestablished, it cannot be emphasized too strongly that a go-around is often the pilot's best course of action, and the earlier the decision to go around, the better the chance of recovery.

## **THUNDERSTORM AVOIDANCE**

Much has been written about thunderstorms. They have been studied for years, and while considerable information has been learned, the studies continue because questions still remain. Knowledge and weather radar have modified our attitudes toward thunderstorms. But any storm recognizable as a thunderstorm should be considered hazardous. Never regard any thunderstorm lightly, even when radar observers report the echoes are of light intensity. Avoiding all thunderstorms is the best policy.

The following are some do's and don'ts of thunderstorm avoidance:

1. Don't land or takeoff in the face of an approaching thunderstorm. A sudden gust front of low level turbulence (wind shear) could cause loss of control.
2. Don't attempt to fly under a thunderstorm, even if you can see through to the other side. Turbulence and wind shear under the storm is likely and hazardous.
3. Don't fly near clouds containing embedded thunderstorms. Scattered thunderstorms that are not embedded usually can be visually circumnavigated.
4. Don't trust the visual appearance to be a reliable indicator of the turbulence inside a thunderstorm.
5. Do avoid, by at least 20 miles, any thunderstorm identified as severe or giving an intense radar echo. This is especially true under the anvil of a large cumulonimbus.
6. Do circumnavigate the entire area if the area has 6/10 thunderstorm coverage.
7. Do remember that vivid and frequent lightning indicates the probability of a severe thunderstorm.

8. Do regard, as extremely hazardous, any thunderstorm with tops 35,000 feet or higher, whether the top is visually sighted or determined by radar.
9. Do check the convective outlook during weather briefings.

The following are some do's and don'ts during inadvertent thunderstorm area penetration:

1. Do keep your eyes on the instruments. Looking outside the cabin can increase the danger of temporary blindness from lightning.
2. Don't change power settings; maintain settings for the recommended turbulent air penetration speed.
3. Do maintain a generally constant attitude.
4. Don't attempt to maintain altitude. Maneuvers made in attempting to maintain an exact altitude increase the stress on the airplane.
5. Exit the storm as soon as possible.

A pilot on an IFR flight plan must not deviate from an approved route or altitude without proper clearance, as this may place him in conflict with other air traffic. Strict adherence to traffic clearance is necessary to assure an adequate level of safety.

Always remember, all thunderstorms are potentially hazardous and the pilot is best advised to avoid them whenever possible.

## **FROM WARM WEATHER TO COLD WEATHER**

Flying from warm weather to cold weather can do unusual things to airplanes. To cope with this problem, pilots must be alerted to a few preparations. If the airplane is serviced with a heavier grade of oil, such as SAE 50, the oil should be changed to a lighter grade such as SAE 30 before flying into very cold weather. If use of a multi-viscosity oil is approved, it is recommended for improved starting in cold weather. Refer to the airplane operating handbook or maintenance manual for approved oils. An engine/airplane winterization kit may be available for the airplane. It usually contains restrictive covers for the cowl nose cap and/or oil cooler and engine crankcase breather for flight in very cold weather. Proper preflight draining of the fuel system from all drains is especially important and will help eliminate any free water accumulation. The use of fuel additives, such as Prist or EGME, may also be desirable. Refer to the airplane operating handbook or maintenance manual for approved fuel additives.

In order to prevent propeller freeze-up when operating in very cold weather, it may be necessary to exercise the constant speed prop every few minutes. This can be accomplished by moving the prop controls forward or aft from their cruise position 300 RPM and back during flight.

## **ICE, SNOW, FROST, Etc.**

For any extended time, it is always best to park an airplane in a hangar, particularly during inclement weather. When this is not possible, all ice, snow, frost, etc., must be removed from the entire airframe and engine(s) prior to starting.

The presence of ice, snow, frost, etc., on the wings, tail, control surfaces (externally and internally), etc., is hazardous. Safe operation depends upon their removal. Too often, their effects on airplane performance are not completely understood or appreciated.

## **WAKE TURBULENCE**

Airplanes are significantly affected by the wake turbulence of any heavier aircraft or helicopter. Wake turbulence dissipation and displacement are functions of elapsed time and prevailing wind speed and direction. During calm conditions, severe turbulence generated by large aircraft can persist as long as 10 minutes. Delay takeoff to ensure dissipation and displacement of wake turbulence. When it is necessary to take off behind a heavier aircraft or helicopter, avoid wake turbulence, particularly wake vortices, by vertical or lateral spacing or an appropriate time delay.

Vertical avoidance is appropriate to longer runways where operations can be completed on portions of the runway not affected by the vortices of preceding aircraft and flying above areas where vortices will be present is possible. Become airborne well before the preceding aircraft rotation point and climb above its flight path, or lift off beyond the touchdown point of a landing aircraft. When it is necessary to land behind another aircraft, remain above its approach path and land beyond its touchdown point. Touchdown prior to the rotation point of a departing aircraft.

Lateral movement of wake vortices is only possible when a significant crosswind exists and is not detectable unless exhaust smoke or dust marks the vortices. Consider offsetting the takeoff path to the upwind side of the runway.



## RESTRAINT SYSTEMS

---

### SEAT RESTRAINTS

Records of general aviation airplane accident injuries reveal a surprising number of instances in which the occupants were not properly using the available restraint system, indicating the presence of a complacent attitude during airplane preflight briefing inspections. An unbuckled restraint system during a critical phase of flight, such as during turbulence, could cause loss of control of the airplane and/or injuries. Although the ultimate responsibility lies with the pilot-in-command, each user of a restraint system should be cognizant of the importance of proper use of the complete restraint system.

Pilots should ensure that all occupants properly use their individual restraint systems. The system should be adjusted snug across the body. A loose restraint belt will allow the wearer excessive movement and could result in serious injuries. The wearer should not allow sharp or hard items in pockets or other clothing to remain between their body and the restraint system to avoid discomfort or injury during adverse flight conditions or accidents. Each occupant must have their own restraint system. Use of a single system by more than one person could result in serious injury.

Occupants of adjustable seats should position and lock their seats before fastening their restraint system. Restraint belts can be lengthened before use by grasping the sides of the link on the link half of the belt and pulling against the belt. Then, after locking the belt link into the belt buckle, the belt can be tightened by pulling the free end. The belt is released by pulling upward on the top of the buckle. Restraint systems must be fastened anytime the airplane is in motion. Before takeoff, the pilot should brief all passengers on the proper use, including the method of unlatching the entire restraint system, in the event that emergency egress from the airplane is necessary.

Small children must be secured in an approved child restraint system as defined in FAR 91.107 "Use of safety belts, shoulder harnesses, and child restraint systems". The pilot should know and follow the instructions for installation and use provided by the seat manufacturer. The child restraint system should be installed in an aircraft seat other than a front seat. If the child restraint system is installed in a front seat, the pilot must ensure that it does not interfere with full control movement or restrict access to any aircraft controls. Also, the pilot should consider whether the child restraint system could interfere with emergency egress. Refer to AC 91-62A, "Use of Child Seats In Aircraft" for more information.

If shoulder restraints are not installed, kits are available from Cessna or from other approved sources. Cessna strongly recommends the installation of shoulder harnesses.

## **SEAT STOPS/LATCHES**

The pilot should visually check the seat for security on the seat tracks and assure that the seat is locked in position. This can be accomplished by visually ascertaining pin engagement and physically attempting to move the seat fore and aft to verify the seat is secured in position. Failure to ensure that the seat is locked in position could result in the seat sliding aft during a critical phase of flight, such as initial climb. Mandatory Service Bulletin SEB89-32 installs secondary seat stops and is available from Cessna.

The pilot's seat should be adjusted and locked in a position to allow full rudder deflection and brake application without having to shift position in the seat. For takeoff and landing, passenger seat backs should be adjusted to the most upright position.

## **SECURITY IN AFT-FACING SEATS**

Some aft-facing seats are adjustable fore and aft, within the limits of the seat stops. Ensure the seat stop pins are engaged with the holes in the seat tracks before takeoff and landing. The restraint system should be worn anytime the seat is occupied. Assure that the seats are installed in the correct positions. Approved seat designs differ between forward-facing and rear-facing seats and proper occupant protection is dependent upon proper seat installation.

## **FUEL SYSTEM CONTAMINATION**

---

### **ADEQUATE PREFLIGHT OF THE FUEL SYSTEM**

A full preflight inspection is recommended before each flight for general aviation airplanes. Inspection procedures for the fuel system must include checking the quantity of fuel with the airplane on level ground, checking the security of fuel filler caps and draining the fuel tank sumps, fuel reservoir(s), fuel line drain(s), fuel selector drains, and fuel strainer(s). To ensure that no unsampled fuel remains in the airplane, an adequate sample of fuel from the fuel strainer must be taken with the fuel selector valve placed in each of its positions (BOTH, LEFT, RIGHT, etc.). Some Cessna airplanes are equipped with a fuel reservoir(s). If so equipped, the pilot should be aware of the location of the fuel reservoir(s) and its drain plug or quick-drain. The fuel reservoir(s) on most single-engine airplanes is located near the fuel system low point where water will accumulate. Therefore, the fuel reservoir(s) must be drained routinely during each preflight inspection. Periodically check the condition of the fuel filler cap seals, pawls, and springs for evidence of wear and/or deterioration which indicates a need for replacement. Check fuel cap adapters and seals to insure that the sealing surfaces are clean and not rusted or pitted. Deformed pawls may affect the sealing capabilities of the seals and/or cause it to be exposed to detrimental weather elements. Precautions should be taken to prevent water entry into fuel tanks, due to damaged filler caps and every effort made to check and remove all water throughout the fuel system. Umbrella caps will assist in preventing water entry into the fuel tank through the fuel filler.

It is the pilot's responsibility to ensure that the airplane is properly serviced before each flight with the correct type of fuel. The pilot must take the time to inspect the airplane thoroughly, making sure all of the fuel filler caps are installed and secured properly after visually checking the fuel quantity with the airplane on level ground. During the check of the fuel tanks, observe the color and odor of the fuel while draining a generous sample from each sump and drain point into a transparent container. Check for the presence of water, dirt, rust, or other contaminants. Never save the fuel sample and risk the possibility of contaminating the system. Also, ensure that each fuel tank vent is clear of restrictions (i.e., dirt, insect nests, ice, snow, bent or pinched tubes, etc.). Refer to the airplanes Maintenance Manual for fuel tank vent removal and inspection if needed.

## **PROPER SAMPLING FROM QUICK DRAINS**

The fuel system sumps and drains should always be drained and checked for contaminants after each refueling and during each preflight inspection. Drain at least a cupful of fuel into a clear container to check for solid and/or liquid contaminants, and proper fuel grade. If contamination is observed, take further samples at all fuel drain points until fuel is clear of contaminants; then, gently rock wings and, if possible, lower the tail to move any additional contaminants to the sampling points. Take repeated samples from all fuel drain points until all contamination has been removed. If excessive sampling is required, completely defuel, drain and clean the airplane fuel system, and attempt to discover where or how the contamination originated before the airplane flies again. Do not fly the airplane with contaminated or unapproved fuel. If an improper fuel type is detected, the mandatory procedure is to completely defuel and drain the fuel system.

Extra effort is needed for a proper preflight of all fuel drains on a float plane. If water is detected after rocking the wings and lowering the tail, the aircraft should not be flown until after the fuel system is completely drained and cleaned.

## **80 versus 100 OCTANE FUEL**

When 80 octane (red) fuel began to be replaced by 100LL (blue) there was concern about the service life expectancy of low compression engines. It was claimed that some engines experienced accelerated exhaust valve erosion and valve guide wear from the use of highly leaded 100/130 (green) avgas in engines that were rated to use a minimum grade of 80 octane fuel. Engine manufacturers have provided amended operating procedures and maintenance schedules to minimize problems resulting from the use of high lead 100/130 avgas. Experience has now proven that low-compression aircraft engines can be operated safely on 100LL avgas providing they are regularly operated and serviced in accordance with the operating handbook or other officially approved document.

## **AVGAS versus JET FUEL**

Occasionally, airplanes are inadvertently serviced with the wrong type of fuel. Piston engines may run briefly on jet fuel, but detonation and overheating will soon cause power failure. All piston-engine airplanes should have fuel filler restrictors installed to prevent jet fuel from being pumped into the fuel tanks. An engine failure caused by running a turbine engine on the wrong fuel may not be as sudden, but prolonged operation on avgas will severely damage the engine because of the lead content and differing combustion temperature of the fuel. Time limitations for use of avgas in turbine engines are listed in the operating handbook.

## **AUTOMOTIVE GASOLINE/FUEL**

Never use automotive gasoline in an airplane unless the engine and airplane fuel system are specifically certified and approved for automotive gasoline use. The additives used in the production of automotive gasoline vary widely throughout the petroleum industry and may have deteriorating effects on airplane fuel system components. The qualities of automotive gasoline can induce vapor lock, increase the probability of carburetor icing, and can cause internal engine problems.

## **FUEL CAP SECURITY**

The consequence of a missing or incorrectly installed fuel filler cap is inflight fuel siphoning. Inflight siphoning may distort the fuel cell on some airplanes with bladder-type fuel cells. This distortion will change the fuel cell capacity, and may interfere with the operation of the fuel quantity indicator sensing mechanism inside the cell. This condition will generally cause an erroneous and misleading fuel quantity reading and may result in incomplete filling for the next flight.

## **CONTAMINATION**

Solid contamination may consist of rust, sand, pebbles, dirt, microbes or bacterial growth. If any solid contaminants are found in any part of the fuel system, drain and clean the airplane fuel system. Do not fly the airplane with fuel contaminated with solid material.

Liquid contamination is usually water, improper fuel type, fuel grade, or additives that are not compatible with the fuel or fuel system components. Liquid contamination should be addressed as set forth in the section entitled "Proper Sampling from Quick Drains", and as prescribed in the airplane's approved flight manual.



## **FUEL PUMP OPERATION**

---

### **AUXILIARY FUEL PUMP OPERATION - GENERAL**

The engine-driven fuel pump is designed to supply an engine with a steady, uninterrupted flow of fuel. Temperature changes, pressure changes, agitation in the fuel lines, fuel quality, and other factors can cause a release of vapor in the fuel system. Some airplanes (single and multi-engine) incorporate an auxiliary fuel pump to reduce excess fuel vapor in the fuel supply for each engine. This pump is also used to ensure that a positive supply of fuel is available in the event the engine driven fuel pump should fail.

### **FUEL VAPOR**

Under hot, high altitude conditions, or in situations during a climb that are conducive to fuel vapor formation, it may be necessary to utilize the auxiliary fuel pump(s) to attain or stabilize the fuel flow required for proper engine operation. Use the auxiliary fuel pump(s) in all conditions where there is any possibility of excessive fuel vapor formation or temporary disruption of fuel flow in accordance with operating handbook procedures.

### **SINGLE ENGINE FUEL PUMP OPERATION (CARBURETED ENGINE)**

On some carbureted, high wing, single engine airplanes, the auxiliary fuel pump should be turned on anytime the indicated fuel pressure falls below the minimum. Typically this would only occur in an extreme climb attitude following failure of the engine driven fuel pump. Consult the operating handbook of the affected model for a detailed description of the procedure.

### **SINGLE ENGINE FUEL PUMP OPERATION (PRECISION/BENDIX FUEL INJECTED ENGINE)**

The auxiliary fuel pump is used primarily for priming the engine before starting. Priming is accomplished through the regular injection system. If the auxiliary fuel pump switch is placed in the ON position for prolonged periods with the master switch turned on, the mixture rich, and the engine stopped, the intake manifolds will become flooded.

The auxiliary fuel pump is also used for vapor suppression in hot weather. Normally, momentary use will be sufficient for vapor suppression. Turning on the auxiliary fuel pump with a normally operating engine pump will result in enrichment of the mixture. The auxiliary fuel pump should not be operated during takeoff and landing, since gravity and the engine driven fuel pump will supply adequate fuel flow to the fuel injector unit. In the event of failure of the engine driven fuel pump, use of the auxiliary fuel pump will provide sufficient fuel to maintain flight at maximum continuous power.

To ensure a prompt engine restart after running a fuel tank dry, switch the fuel selector to the opposite tank at the first indication of fuel flow fluctuation or power loss. Turn on the auxiliary fuel pump and advance the mixture control to full rich. After power and steady fuel flow are restored, turn off the auxiliary fuel pump and lean the mixture as necessary.

### **SINGLE ENGINE FUEL PUMP OPERATION (TCM FUEL INJECTED ENGINE)**

The auxiliary fuel pump on single engine airplanes is controlled by a split rocker type switch labeled AUX PUMP. One side of the switch is red and is labeled HI; the other side is yellow and is labeled LO.

The LO side operates the pump at low speed, and, if desired, can be used for starting or vapor suppression. The HI side operates the pump at high speed, supplying sufficient fuel flow to maintain adequate power in the event of an engine driven fuel pump failure. In addition, the HI side may be used for normal engine starts, vapor elimination in flight, and inflight engine starts.

When the engine driven fuel pump is functioning and the auxiliary fuel pump is placed in the HI position, a fuel/air ratio considerably richer than best power is produced unless the mixture is leaned. Therefore, the auxiliary fuel pump must be turned off during takeoff or landing, and during all other normal flight conditions. With the engine stopped and the battery switch on, the cylinder intake ports can become flooded if the HI or LO side of the auxiliary fuel pump switch is turned on.

In hot, high altitude conditions, or climb conditions that are conducive to fuel vapor formation, it may be necessary to utilize the auxiliary fuel pump to attain or stabilize the fuel flow required for the type of climb being performed. Select either the HI or LO position of the switch as required, and adjust the mixture to the desired fuel flow. If fluctuating fuel flow (greater than 5 lbs/hr) is observed, place the auxiliary fuel pump switch in the HI or LO position as required to clear the fuel system of vapor. The auxiliary fuel pump may be operated continuously in cruise, if necessary, but should be turned off prior to descent. Each time the auxiliary fuel pump switch is turned on or off, the mixture should be readjusted.

## **MULTI-ENGINE FUEL PUMP OPERATION**

Cessna multi-engine, low wing airplanes utilize engine driven fuel pumps to assist the continuous flow of fuel to the engine. As a general rule, the auxiliary fuel pumps should be utilized under the following conditions:

1. Every takeoff.
2. Initial climb after takeoff (unless the operating handbook indicates that it is not necessary).
3. When switching the fuel selector(s) from one tank to another.
4. Every approach and landing.
5. Anytime the fuel pressure is fluctuating and the engine is affected by the fluctuation.
6. During hot weather, such as hot engine ground operation where fuel vapor problems cause erratic engine operation.
7. High altitude. (For auxiliary fuel pump operation at high altitude consult the operating handbook.)
8. If the engine driven fuel pump should fail.
9. On some twins when using the auxiliary fuel tanks.

If the auxiliary fuel pump is used during ground operations, such as hot day engine starts or purging fuel vapor, pilots should check the condition of the engine driven fuel pump before takeoff by turning the auxiliary fuel pump OFF briefly, and then back ON for takeoff. If the engine driven fuel pump has failed, the engine will not continue to operate.

If the battery or master switch is on while an engine is stopped on the ground or in flight, the cylinder intake ports can become flooded if the auxiliary fuel pump is turned on. If this situation occurs in excess of 60 seconds, the cylinders must be purged as follows:

1. With the auxiliary fuel pump OFF, allow the induction manifold to drain at least five minutes or until fuel ceases to flow from the drains on the bottom of the engine.
2. If natural draining has occurred, ensure that the auxiliary fuel pump is OFF, the magnetos or ignition switch is OFF, the mixture is in IDLE CUT-OFF, and the throttle is FULL OPEN, then turn the engine with the starter.
3. If natural draining has not occurred, perform maintenance as required.

A mandatory service bulletin (MEB88-3) was issued to replace the automatic fuel pressure sensing and the cockpit auxiliary fuel pump switches for each engine with three-position lever lock type toggle switches. These modifications provide direct pilot activation of the auxiliary fuel pumps.

On low wing multi-engine airplanes (except model 310, 310A, and 310B, which are not affected by this change), the switches are labeled AUX PUMP, L (left engine) and R (right engine) and switch positions are labeled LOW, OFF, and HIGH. The LOW position operates the auxiliary fuel pumps at low pressure and can be used, when required, to provide supplementary fuel pressure for all normal operations. The switches are OFF in the middle position. The HIGH position is reserved for emergency operation, and operates the pumps at high pressure. The switches are locked out of the HIGH position and the switch toggle must be pulled to clear the lock before it can be moved to the HIGH setting. The toggle need not be pulled to return the switch to OFF.

The LOW position of the auxiliary fuel pump switches should be used whenever an original manual/handbook or checklist procedure specifies either LOW (PRIME, in 310C, 310D 310F, 310G, 310H, 320, and 320A.) or ON. The LOW position is also used anytime there are indications of vapor, as evidenced by fluctuating fuel flow. Auxiliary fuel pumps, if needed, are to be operated on LOW in all conditions except when an engine driven fuel pump fails.

The HIGH position supplies sufficient fuel flow to sustain partial engine power and should be used solely to sustain the operation of an engine in the event its engine driven fuel pump fails. Failure of an engine driven fuel pump will be evidenced by a sudden reduction in the fuel flow indication immediately prior to a loss of power while operating from a fuel tank containing adequate fuel. In an emergency, where loss of an engine driven fuel pump is involved, pull the applicable auxiliary fuel pump switch to clear the lock and select the HIGH position. Then adjust the throttle and mixture controls to obtain satisfactory operation. At high manifold pressure and RPM, auxiliary fuel pump output may not be sufficient for normal engine operation. In this case, reduce manifold pressure to a level compatible with the indicated fuel flow. At low power settings, the mixture may have to be leaned for smooth engine operation. If HIGH auxiliary pump output does not restore adequate fuel flow, a fuel leak may exist. The auxiliary pump should be shut off and the engine secured.

If the auxiliary fuel pump switches are placed in the HIGH position with the engine-driven fuel pump(s) operating normally, total loss of engine power may occur due to flooding.

When performing single engine operations, the auxiliary fuel pump of the engine to be shutdown should be turned OFF prior to any intentional engine shutdown, to preclude fuel accumulation in the engine intake system.

In models 310, 310A, and 310B, which are equipped with pressure type carburetors, the electric fuel boost pumps in the tanks provide a positive fuel flow as emergency pumps in the event of failure of the engine driven fuel pumps. They also provide fuel pressure for priming and starting. The boost pumps are operated by two electric switches, and the up position is ON. Always take off and land with these pumps turned ON. Anytime the boost pumps are turned on without the engines running, mixture controls must be in the idle cut-off position to prevent flooding the intake manifolds.

### **CENTERLINE THRUST TWINS (FUEL PUMP OPERATION)**

The auxiliary fuel pumps on the centerline thrust models (336 and 337 Skymaster) are controlled by two split rocker type switches. The switches are labeled AUX PUMPS and F ENGINE R. One side of each switch is red and is labeled HI. The other side is yellow and is labeled LO. The LO side operates the pumps at low speed, and if desired, can be used for starting or vapor suppression. The HI side operates the pumps at high speed, supplying sufficient fuel flow to maintain adequate power in the event of an engine driven fuel pump failure. In addition, the HI side may be used for normal engine starts, vapor elimination in flight, and inflight engine starts.

When the engine driven fuel pump is functioning and the auxiliary fuel pump is placed in the HI position, a fuel/air ratio considerably richer than best power is produced unless the mixture is leaned. Therefore, these switches must be turned OFF during takeoff or landing, and during all other normal flight conditions. With the engine stopped and the battery switch ON, the cylinder intake ports can become flooded if the HI or LO side of the auxiliary fuel pump switch is turned on.

In hot, high altitude conditions, or climb conditions that are conducive to fuel vapor formation, it may be necessary to utilize the auxiliary fuel pumps to attain or stabilize the fuel flow required for the type of climb being performed. Select either the HI or LO position of the switches as required, and adjust the mixtures to the desired fuel flow. If fluctuating fuel flow (greater than 5 lbs/hr) is observed, place the appropriate auxiliary fuel pump switch in the HI or LO position as required to clear the fuel system of vapor. The auxiliary fuel pump may be operated continuously in cruise, if necessary, but should be turned off prior to descent. Each time the auxiliary fuel pump switches are turned on or off, the mixtures should be readjusted.



## AUXILIARY FUEL TANKS

---

Many twin engine Cessna airplanes incorporate auxiliary fuel tanks to increase range and endurance. These tanks are usually bladder type cells located symmetrically in the outboard wing areas and contain no internal fuel pumps. When selected, the fuel from these tanks is routed to the engine driven fuel pump.

If the auxiliary fuel tanks are to be used, the pilot must first select main tank (tip tank) fuel for at least 60 minutes of flight (with use of 40-gallon auxiliary fuel tanks) or 90 minutes of flight (with use of 63-gallon auxiliary fuel tanks). This is necessary to provide space in the main fuel tanks for vapor and fuel returned from the engine driven fuel pumps when operating on the auxiliary fuel tanks. If sufficient space is not available in the main tanks for this returned fuel, the tanks can overflow through the overboard fuel vents. Since part of the fuel from the auxiliary fuel tanks is diverted back to the main tanks instead of being consumed by the engines, the auxiliary tanks will empty sooner than may be anticipated. However, the main tank volume or quantity will be increased by the returned fuel.

The fuel supply in the auxiliary fuel tanks is intended for use during cruise flight only. The shape of the auxiliary fuel tanks is such that during certain flight maneuvers, the fuel will move away from the fuel tank outlet. If the outlet is uncovered while feeding the engine, fuel flow to the engine will be interrupted and a temporary loss of power may result. Because of this, operation from the auxiliary fuel tanks is not recommended below 1000 feet AGL.

An optional auxiliary fuel tank may be installed on some centerline thrust twins (336 and 337 Skymaster). The system consists of two tanks, each containing 18 gallons (108 pounds) usable, one located in each inboard wing panel. The tanks feed directly to the fuel selector valves. The left auxiliary tank provides fuel to the front engine only and the right auxiliary tank provides fuel to the rear engine only. Fuel quantity for the auxiliary tanks is read on the same fuel quantity indicators used for the main fuel tanks. This is accomplished when the fuel selector valve handles are turned to the AUXILIARY position. As each selector valve handle is turned to this position, it depresses a gaging button, labeled PUSH TO GAGE, located in the AUXILIARY quadrant of the fuel selector valve placard. The depressed button actuates a microswitch and electrically senses auxiliary fuel rather than main fuel quantity. Auxiliary fuel quantity can be checked without changing the selector valve handle, by depressing the PUSH TO GAGE button manually. Depressing the gaging button, either manually or by rotating the selector valve handle to the AUXILIARY position, will illuminate the amber AUX FUEL ON indicator lights mounted above the

engine instrument cluster. When fuel is being used from the auxiliary fuel tanks, any excess fuel and vapor from the engine driven pumps is returned to fuel line manifolds. The returned vapor passes through the fuel line manifolds to the vent lines and is routed overboard. The excess fuel passes into the fuel line manifold and is returned to the engine driven pumps.

On some early model Skymasters, fuel vapor from the engine driven fuel pumps is returned to the main fuel tanks. When the selector valve handles are in the AUXILIARY position, the left auxiliary tank feeds only the front engine and the right auxiliary tank feeds only the rear engine. If the auxiliary tanks are to be used, select fuel from the main tanks for 60 minutes prior to switching to auxiliary tanks. This is necessary to provide space in the main tanks for vapor and fuel returned from the engine driven fuel pumps when operating on auxiliary tanks. On some models, auxiliary fuel boost pumps are not provided for the auxiliary fuel tank. Therefore it is recommended to use the auxiliary fuel tanks only in straight and level flight. When unsure of the type of auxiliary tank installation, consult the operating handbook for the respective airplane.

A few single-engine airplanes contain an auxiliary fuel tank. The system's main components include a fuel tank installed on the baggage compartment floor and an electric fuel transfer pump. The auxiliary fuel system is plumbed into the right main fuel tank.

To use the auxiliary fuel system, select the right wing fuel tank in cruise and operate on that tank until the fuel tank has adequate room for the transfer of auxiliary fuel. After selecting the left main tank, turn on the auxiliary fuel transfer pump to refill the right main fuel tank from the auxiliary tank. Transfer will take from 45 minutes to 1 hour. Prior to transfer, ensure that adequate fuel is available in the left tank to allow time for the auxiliary tank to transfer.

Do not operate the transfer pump with the fuel selector valve turned to either the BOTH or RIGHT positions. Total or partial engine stoppage will result from air being pumped into fuel lines after fuel transfer has been completed. If this should occur the engine will restart in 3 to 5 seconds after turning off the transfer pump, as the air in the fuel line will be evacuated rapidly.

After transfer is complete and the pump has been turned off, the selector may be returned to BOTH or RIGHT. Takeoff, climb, and landing should always be conducted with the selector in the BOTH position for maximum safety.

## **WING LOCKER FUEL TANK USAGE**

Some twins may have wing locker fuel tanks installed in the forward portion of each wing locker baggage area. These tanks are bladder type cells for storage of extra fuel to supplement the main tank fuel

quantity. The fuel in these tanks cannot be fed directly to the engines. Instead, it has to be transferred to the main tanks by wing locker fuel transfer pumps. Fuel transfer should begin as soon as adequate volume is available in the main fuel tanks to hold the wing locker fuel. Waiting until the main tanks are low before transferring wing locker fuel does not allow early recognition of possible failure to transfer.

If wing locker fuel is to be used, consult the operating handbook for the quantity of main tank fuel which must first be used in the respective main tank for the transferred wing locker fuel. This will prevent overflowing of the main tank(s) when transferring the wing locker fuel.

Wing locker fuel transfer pump switches are provided to manually control the transfer of the wing locker fuel to the main tanks. These switches should be turned ON only to transfer fuel and turned OFF when indicator lights illuminate to show that fuel has been transferred. The transfer pumps use the fuel in the wing locker tank for lubrication and cooling. Therefore, transfer pump operation after fuel transfer is complete will shorten the life of the pump, Fuel should be cross fed, as required, to maintain fuel balance.



## INSTRUMENT POWER

---

### VACUUM POWER FAILURES

Many airplanes may be equipped with some type of back-up vacuum system for operation in the event the primary vacuum system becomes inoperative in flight. The backup system may be in the form of another engine-driven vacuum pump, in parallel with the primary pump, or an electric standby vacuum pump, also in parallel with the primary pump, or both. If a back-up system is not available and the attitude and directional indicators are disabled, the pilot must rely on partial instrument panel operation. This may include using the electrically-powered turn coordinator or turn and bank indicator and the magnetic compass, altimeter, airspeed indicator, and rate of climb indicator.

A suction gage, and in some airplanes a low-vacuum warning light, provides a means of monitoring the vacuum system for proper operation in flight. Operating handbooks reflect a desired suction range during normal operation of the airplane. A suction reading outside of this range may indicate a system malfunction, and in this case, the vacuum driven instruments should not be considered reliable. Whenever operation of the airplane's vacuum system is in doubt, land when practical for repairs.

In the event of a directional indicator and attitude indicator failure due to vacuum failure, the pilot must rely on partial instrument panel operation using the remaining instruments. VFR operations can generally be conducted satisfactorily without the vacuum instruments. However, instrument meteorological conditions (IMC) can be considerably more challenging. An instrument rated pilot should stay current on partial panel flying skills but both VFR and IFR pilots should maintain VFR conditions if a vacuum failure occurs while clear of clouds. All pilots should become familiar with the following procedure for executing a 180° turn in clouds with the aid of either the turn coordinator or the turn and bank indicator.

Upon inadvertently entering clouds, maintain control of the aircraft. If it is desired to turn back out of the clouds, the following action should be employed:

1. Note the compass heading.
2. Note the time in both minutes and seconds.
3. When the seconds indicate the nearest half minute, initiate a standard rate left turn, holding the turn coordinator or turn and bank indicator (if installed) symbolic airplane wing opposite the lower left index mark for 60 seconds. Then roll back to level flight by leveling the miniature airplane.
4. Check accuracy of turn by observing the compass heading which should be the reciprocal of the original heading.

5. If necessary, adjust heading primarily with skidding motions rather than rolling motions so that the compass will read more accurately.
6. Maintain altitude and airspeed by cautious application of elevator control. Avoid over controlling by keeping the hands off the control wheel as much as possible and steering only with the rudder.

If conditions dictate, a descent through a cloud deck to VFR conditions may be appropriate. To guard against a spiral dive, choose an easterly or westerly heading to minimize compass card swings due to changing bank angles. In addition, keep hands off the control wheel and steer a straight course with rudder control by monitoring the turn coordinator. Occasionally check the compass heading and make minor corrections to hold an approximate course. Before descending into the clouds, set up a stabilized let-down conditions as follows:

1. Extend landing gear (if applicable).
2. Enrichen the fuel mixture.
3. Use full carburetor heat (if applicable).
4. Reduce power to set up a 500 to 800 ft/min rate of descent.
5. Adjust the elevator trim and rudder trim (if installed) for a stabilized descent at 5 to 20 knots above the best glide speed for the airplane.
6. Keep hands off the control wheel.
7. Monitor turn coordinator and make corrections by rudder alone.
8. Check trend of compass card movement and make cautious corrections with rudder to stop the turn.
9. Upon breaking out of clouds, resume normal cruise flight.

## **ELECTRICAL POWER FAILURES**

Many operating handbooks have emergency procedures for partial or total loss of electrical power in flight. These procedures should be reviewed periodically to remain knowledgeable of what to do in the event of an electrical problem. The pilot should maintain control of the airplane and land when practical if an electrical power loss is evident.

Early detection of an electrical power supply system malfunction can be accomplished by periodically monitoring the ammeter and, if equipped, low voltage warning light. The cause of these malfunctions is difficult to determine in flight. Common causes of alternator or generator failure are a broken drive belt, alternator or generator drive, a defective alternator control unit or voltage regulator or wiring. Problems of this nature constitute an electrical emergency and should be addressed immediately.

If alternator power cannot be restored, and a second or back up alternator is not available, the pilot must rely on the limited power of the

battery only. Every effort should be made to conserve electrical power for use with the most essential equipment, such as communication and navigation radios, by turning off or not using any non-essential equipment. Electric or electro-hydraulic landing gear systems should be extended manually and flaps (if electrically operated) should remain retracted during approach and landing to conserve battery power, especially in instrument conditions.

If an electrical power loss is experienced, continued flight is possible but should be terminated as soon as practical. Such things as fuel quantity and engine temperature indicators and panel lights may no longer work. Hand-held nav/comm radios and other such products are widely available and marketed for just such a scenario; otherwise navigation by pilotage and appropriate loss of communication procedures for the airspace involved should be conducted. The pilot should always have a flashlight available for night flights.

## **LOSS OF PITOT/STATIC SOURCES**

A thorough preflight inspection should reveal any blockage of the pitot tube, drain hole, or static port on the ground to allow corrective action to be taken prior to flight. Pilots should understand the various conditions and remedies associated with a loss of pitot-static sources.

Pitot heat should be used whenever flying in visible moisture and the temperature is near freezing. If airspeed is suspected to be in error while flying in possible icing conditions with the pitot heat on, the pitot heat switch should be cycled and the circuit breaker should be checked. If proper operation cannot be restored, the airspeed indicator must be considered unreliable.

If the pitot tube ram air inlet becomes blocked, the airspeed will drop to zero. If this blockage cannot be removed in flight, the pilot must rely on pitch attitude and power settings to maintain a safe airspeed. A slightly higher than normal power setting should be used to maintain a reasonable margin of extra airspeed on final.

When flying in clear ice conditions and pitot heat is unavailable, both the ram air inlet and the pitot drain hole could become blocked. This will cause the airspeed indicator to react like an altimeter, indicating a higher airspeed at higher altitudes and a lower airspeed at lower altitudes. The airspeed indicator must be ignored. A higher power setting appropriate to the overall icing problem should be used during the landing phase.

Many light single engine airplanes equipped with pitot heat may not be equipped with static source heat. If the static source becomes blocked, the airspeed indicator will still function, but will give erroneous indications. If the airplane climbs after the blockage occurs, the airspeed indicator will indicate lower than normal. If the airplane descends after the blockage occurs, the airspeed will indicate higher

than actual. During the landing phase, this condition could deceive the pilot into thinking the airspeed is too high. The altimeter and vertical speed indicator will also be affected by a static source blockage. The altimeter will not indicate a change of altitude and the vertical speed indicator will indicate zero during climbs and descents. Neither instrument will reflect any altitude changes.

Many airplanes are equipped with an alternate static air source vented within the cabin area. If static port blockage is suspected, the alternate static source should be selected. The cabin pressure will be slightly lower than ambient air, but will provide a reasonable level of accuracy to the pitot static system. With slightly less dense air in the cabin, the airspeed indicator and altimeter will both show slightly higher than normal indications.

If the airplane is not equipped with an alternate static source, and pitot/static instruments are essential for continued flight, the glass on the vertical speed indicator may be broken to provide cabin air to the static system lines. The vertical speed indicator will no longer be reliable, but the airspeed indicator and altimeter will be functional again, with slightly higher than normal indications.

## **GYRO SPIN UP AND SPIN DOWN**

Gyro instruments, such as attitude and directional indicators, contain a high-speed rotor assembly driven by either electric or vacuum power. These instruments normally operate at very high RPM and can take up to 10 minutes or more to spin down after power is removed. Although some gyro instruments have a "quick erect" mechanism to permit manual erection of the rotor, which effectively minimizes time required before use, some gyro instruments still require up to 5 minutes or more to spin up and stabilize after power is applied. During this spin up or spin down time, the gyro instruments should not be considered reliable. A failed gyro can be detected by first checking the suction gage and, if available, low-voltage or low-vacuum lights as applicable and, second, checking for slow or erratic indications of the gyro instruments by cross-referencing with other flight instruments for contradictory indications.

## **FAILED GYRO EFFECT ON AUTOPILOT**

Some autopilot systems receive roll and/or yaw rate inputs from the electrically-driven turn coordinator or turn and bank indicator. Other autopilot systems depend on vacuum-driven attitude and directional indicators for horizontal and azimuth reference. If a failure should occur in any of these instruments, the autopilot should be turned off. Random signals generated by a malfunctioning gyro could cause the autopilot to position the airplane in an unusual attitude. Use of the autopilot after a gyro failure may result in an out of trim condition. Be prepared to correct for this when turning off the autopilot.

## **ALTERNATE AIR SYSTEM**

---

An alternate source of air is provided to ensure satisfactory engine operation in the event the normal induction air filter or air inlet becomes obstructed. Although alternate air controls vary from one airplane to another, the types are: carburetor heat, direct manual control, automatic control, or a combination of automatic and manual controls. In most cases, the alternate air is extracted from inside the engine cowling and is, therefore, unfiltered and hotter than normal induction air. A loss of power will be caused by the hotter air. The richer mixture may require adjustment of the mixture control. Consult the applicable airplane operating handbook for details concerning the use of the alternate air system.

### **CARBURETOR HEAT AND INDUCTION ICING**

Carburetor heat and manually operated alternate air valve(s) are controlled by the pilot. The carburetor heat system uses unfiltered air from inside the engine cowling. This air is drawn into a shroud around an exhaust riser or muffler and then ducted to the carburetor heat valve in the induction air manifold. The carburetor heat valve is controlled by the pilot and should be used during suspected or known carburetor icing conditions. Carburetor heat may also be used as an alternate air source should the induction air inlet or induction air filter become blocked for any reason.

The use of full carburetor heat at full throttle usually results in a 1 to 2 inch loss of manifold pressure or a loss of approximately 150 RPM, depending upon the airplane model. Application or removal of carburetor heat at higher power settings may require adjustment of the fuel mixture. It may be impractical to lean the mixture under low engine power conditions.

When a go-around or balked landing is initiated after use of carburetor heat during the landing approach, the pilot should usually advance the throttle first, then move the carburetor heat to off or cold. The throttle application must be smooth and positive. Rapid throttle advancement in some icing conditions could result in the engine failing to respond and the loss of power could become critical because of the low altitude and low airspeed.

When the relative humidity is more than 50 percent and the ambient air temperature is between 20°F to 90°F, it is possible for ice to form inside the carburetor, since the temperature of the air passing through the venturi may drop as much as 60°F below the ambient air temperature. If not corrected, ice accumulation may cause complete engine stoppage.

A drop in engine RPM on fixed pitch propeller airplanes and a drop in engine manifold pressure on constant speed propeller airplanes are indications of carburetor ice. If the airplane is equipped with a carburetor air temperature gage, the possibility of carburetor ice may be anticipated and prevented by maintaining the recommended amount of heat during cruise and letdown. Without the indications of a carburetor air temperature gage for reference, a pilot should use only the full heat or full cold position. An unknown amount of partial heat can cause carburetor ice. This can occur when ice that would ordinarily pass through the induction system is melted by partial carburetor heat and the water droplets then refreeze upon contact with the cold metal of the throttle plate. A carburetor air temperature gage may allow partial carburetor heat use, resulting in less power loss.

### **ALTERNATE AIR FOR FUEL INJECTED ENGINE ICING**

Either an automatic alternate air system, a manually controlled alternate air system, or a combination automatic and manual system are incorporated on most fuel injected engines to address the potential of a blocked air induction system.

On engines equipped with automatic alternate air, ram air from the engine cowling inlet enters an air filter, which removes dust and other foreign matter that would be harmful to the engine. If the air inlet or the induction air filter should become blocked, suction created by the engine will open an alternate air door, allowing air to be admitted from either inside or outside the cowling, depending upon the airplane model. This air bypasses the filter and will result in a slight decrease in full throttle manifold pressure on non-turbocharged engines, and a notable decrease in manifold pressure from the selected cruise power setting on turbocharged engines. This manifold pressure, may be recoverable, up to a particular altitude, with throttle and/or RPM adjustment. The alternate air doors should be kept closed on the ground to prevent engine damage caused by ingesting debris through the unfiltered air ducts. For details concerning a specific model, consult the airplane operating handbook.

Most twin engine airplanes have a manually controlled alternate air door in each engine induction air system. If a decrease in manifold pressure is experienced when flying in icing conditions, the alternate air doors should be manually opened. On most twins, this manual control has two positions. When fully in, normal filtered ram air is provided; when fully out, warm unfiltered air from inside the cowling is provided. Other twins have alternate air controls with an additional intermediate or center detent to provide cool, unfiltered ram air to the induction system in the event the induction air filter is blocked by matter other than ice.

Since the higher intake air temperature of the alternate air results in a decrease in engine power and turbocharger capability, it is recommended that the alternate induction air not be utilized until indications of induction air blockage (decreased manifold pressure) are actually observed.

If additional power is required, the pilot should increase RPM as required, move the throttles forward to maintain desired manifold pressure and readjust the fuel mixture controls as required. These recommendations do not replace the procedure in the airplane operating handbook.

Although most pilots are aware of the potential of carburetor icing, many may think that a fuel injected engine is not subject to induction icing. Although a fuel injected engine will not form carburetor ice, other parts of the induction system such as bends in the system or the air filter can gather ice. Slush and/or snow can block the induction air filter. Induction air blockage can cause loss of manifold pressure or engine stoppage.



## **CARBON MONOXIDE**

---

Carbon monoxide is a colorless, odorless, tasteless product of an internal combustion engine and is always present in exhaust fumes. Even minute quantities of carbon monoxide breathed over a long period of time may lead to dire consequences. Carbon monoxide has a greater ability to combine with the blood than oxygen. Once carbon monoxide is absorbed in the blood, it prevents the oxygen from being absorbed.

The symptoms of carbon monoxide poisoning are difficult to detect by the person afflicted and may include blurred thinking, a feeling of uneasiness, dizziness, headache, and loss of consciousness. If any of these symptoms occur, immediately open all cabin vents and turn the cabin heater off. Land as soon as possible at the nearest airport and seek medical attention if needed.

### **HEATER OPERATION**

Many cabin heaters in general aviation airplanes operate by allowing ambient air to flow through an exhaust shroud where it is heated before being ducted into the cabin. Therefore, if anyone in the cabin smells exhaust fumes when using the cabin heater, immediately turn off the cabin heater and open all cabin vents. Land as soon as possible at the nearest airport and seek medical attention if needed.

### **WINDOW VENTILATION**

If carbon monoxide is suspected in the cabin at any time, it is imperative that immediate ventilation be initiated, including the opening of cabin windows. Observe the maximum speed for window opening in flight. Opening a cabin window is probably the best means of ventilating the cabin while on the ground. However, care should be taken when parked with engine(s) operating or when in the vicinity of other airplanes that have their engines running. The exhaust gases from your airplane or the other airplane could enter the cabin through the open window. Also, engine exhaust could be forced into the cabin area during taxi operations or when taxiing downwind.

### **PRESSURIZED AIRPLANES**

Refer to the operating handbook and/or approved flight manual for appropriate ventilation procedures.



## **TURBOCHARGER**

---

When operating turbocharged engines, any power increases should be accomplished by increasing the propeller RPM first, then increasing the manifold pressure. Power reductions should be accomplished by reducing the manifold pressure first, then the RPM.

During cold weather operation, care should be exercised to insure that overboost does not occur during takeoff as a result of congealed oil in the waste gate actuating system. Before takeoff engine checks should not be accomplished until oil temperature is at least 75°F (minimum approved operating limit). Takeoff should not be started until oil temperature is above 100°F and oil pressure below 100 psi to assure proper oil flow to the turbocharger and its actuating system. Monitor manifold pressure during takeoff so as not to exceed specified takeoff limits. Advance the throttle slowly, pausing momentarily at approximately 30" MP to permit turbine speed to stabilize, then gradually open the throttle to obtain takeoff manifold pressure.

Prior to engine shut down, operate the engine at idle RPM for approximately 5 minutes to allow the turbocharger to cool and slow down. This reduces the possibility of turbine bearing coking caused by oil breakdown. This 5 minutes may be calculated from landing touchdown.

During pilot training, simulated engine out operation requiring the engine be shut down by closing the mixture should be held to an absolute minimum.

### **TURBOCHARGER FAILURE**

The turbocharger system's purpose is to elevate manifold pressure and thus engine power to a level higher than can be obtained without it. A failure of the system will cause either an overboost condition or some degree of power loss. An overboost can be determined on the manifold pressure instrument and can be controlled by a throttle reduction.

If turbocharger failure results in power loss, it may be further complicated by an overly rich mixture. This rich mixture condition may be so severe as to cause a total power failure. Leaning the mixture may restore partial power. Partial or total power loss may also be caused by an exhaust system leak. A landing should be made as soon as practical for either an overboost or partial/total power loss.



## IN-FLIGHT FIRES

---

### FIRES IN FLIGHT

A preflight checklist is provided to aid the pilot in detecting conditions which could contribute to an airplane fire. Flight should not be attempted with known fuel, oil, or exhaust leaks, since they can lead to a fire. The presence of fuel or unusual oil or exhaust stains may be an indication of system leaks and should be corrected prior to flight.

Fires in flight must be controlled as quickly as possible by identifying and shutting down the affected system(s), then extinguishing the fire. Until this process is complete, the pilot should assume the worst and initiate action for an immediate landing. A pilot must not become distracted by the fire to the point that control of the airplane is lost. The pilot must be able to complete a deductive analysis of the situation to determine the source of the fire. Complete familiarity with the airplane and its systems will prove invaluable should a fire occur.

### ENGINE COMPARTMENT FIRES

An engine compartment fire is usually caused by fuel contacting a hot surface, an electrical short, bleed air leak, or exhaust leak. If an engine compartment fire occurs on a single engine airplane, the first step should be to shut off the fuel supply to the engine by placing the mixture to idle cut off and the fuel selector/shutoff valve to the OFF position. The ignition switch should be left ON in order for the engine to use up the fuel which remains in the fuel lines and components between the fuel selector/shutoff valve and the engine. The airplane should be put into a sideslip, which will tend to keep the flames away from the occupants and the fuel tanks. If this procedure is ineffective, the pilot must make the most rapid emergency descent possible and an immediate landing.

In multi-engine airplanes, **both** auxiliary fuel pumps should be turned off to reduce pressure in the total fuel system (each auxiliary fuel pump pressurizes a crossfeed line to the opposite fuel selector). If equipped, the emergency crossfeed shutoff should also be activated. The engine on the wing in which the fire exists should be shut down and its fuel selector positioned to OFF even though the fire may not have originated in the fuel system. The cabin heater draws fuel from the crossfeed system on some airplanes, and should be turned off as well. The engine compartment fire extinguisher should be discharged if the airplane is so equipped.

An open foul weather window or emergency exit may produce a low pressure in the cabin. To avoid drawing the fire into the cabin area, the foul weather window, emergency exits, or any openable windows should be kept closed. This condition is aggravated on some models, with the landing gear and wing flaps extended. Therefore, it is

recommended to lower the landing gear as late in the landing approach as possible. A no flap landing should also be attempted, if practical.

## **ELECTRICAL FIRES**

The initial indication of an electrical fire is usually the distinct odor of burning insulation. Once an electrical fire is detected, the pilot should attempt to identify the effected circuit by checking circuit breakers, instruments, avionics, etc. If the affected circuit cannot be readily detected and flight conditions permit, the battery/master switch and alternator switch(es) should be turned OFF to remove the possible sources of the fire. If at night, ensure the availability of a flashlight before turning off electrical power. Then, close off ventilating air as much as practical to reduce the chances of a sustained fire. If an oxygen system is available in the airplane and no visible signs of flame are evident, occupants should use oxygen until smoke clears.

If electrical power is essential for the flight, an attempt may be made to identify and isolate the effected circuit by turning the Master Switch and other electrical (except magneto) switches off and checking the condition of the circuit breakers to identify the affected circuit. If the circuit can be readily identified, leave it deactivated and restore power to the other circuits. If the circuit cannot be readily identified, turn the Master Switch on, and select switches that were on before the fire indication, one at a time, permitting some time to elapse after each switch is turned on, until the short circuit is identified. Make sure the fire is completely extinguished before opening vents. Land as soon as possible for repairs.

## **CABIN FIRES**

Fire or smoke in the cabin should be controlled by identifying and shutting down the affected system, which is most likely to be electrical in nature, and landing as soon as possible. Smoke may be removed by opening the cabin air controls. However, if the smoke increases in intensity when the air controls are opened, they should be closed as this indicates a possible fire in the heating system, nose compartment baggage area, or that the increase in airflow is aggravating this condition.

In pressurized airplanes, the pressurization air system will remove smoke from the cabin. However, if the smoke is intense, it may be necessary to either depressurize at altitude, if oxygen is available for all occupants, or execute an emergency descent to 10,000 feet, terrain permitting. "Ram Air Dump" handle may be pulled to aid the clearing of smoke from the cabin.

The pilot may choose to expel the smoke through the foul weather window(s). The foul weather window(s) should be closed immediately if the fire becomes more intense when the window(s) are opened. If smoke is severe, and there are no visible signs of flame, use oxygen masks (if installed) and begin an immediate descent.

If a fire extinguisher is used, ventilate the cabin promptly after extinguishing the fire to reduce the gases produced by thermal decomposition. If the fire cannot be extinguished immediately, land as soon as possible.



## **IN-FLIGHT OPENING OF DOORS**

---

The occurrence of an inadvertent door opening is not as great of a concern to the safety of the flight, as the pilot's reaction to the opening. If the pilot is overly distracted, loss of airplane control may result even though disruption of airflow by the door is minimal. While the shock of a sudden loud noise and increase in sustained noise level may be surprising, mental preparation for this event and a plan of action can eliminate inappropriate pilot reaction.

### **INADVERTENT OPENING OF BAGGAGE/CARGO DOORS**

The flight characteristics of an airplane will not normally be affected by an open baggage or cargo door. The aerodynamic effects on an open door can vary, depending on the location of the door on the airplane and the method used to hinge the door in relation to the slipstream. Baggage/cargo doors mounted on the side of the aft fuselage and hinged at the front will tend to stay in a nearly closed position at most airspeeds and pose no special problems as long as the airplane is not in uncoordinated flight in a direction which would permit unsecured baggage to fall out of the airplane. Because of the door location and the presence of baggage in the immediate area, the door may not be accessible for closing in flight. Passengers, especially children, should never be allowed to occupy the baggage portion of the cabin for the purpose of closing the door in flight. The pilot should slow the airplane to minimize buffeting of the door and land as soon as practical.

Top hinged baggage/cargo doors will react differently than front hinged doors if improperly latched before takeoff. Doors of this type, may pop open at rotation because of the increase in angle of attack and the slipstream pushing underneath the edge of the unsecured door. After the initial opening, a baggage door will generally tend to stay open and then may gently close as speed is reduced and the aircraft is configured for landing (the doors will probably tend to open again during flair). A top hinged door on the side of the aft fuselage of a high wing airplane can sometimes be moved to a nearly closed position by lowering the wing flaps full down (within approved airspeed limitations) so that wing downwash will act upon the door. Unlatched nose baggage doors and large cargo doors on the side of the aft fuselage cannot be closed in flight and a landing should be made as soon as practical. The pilot should avoid any abrupt airplane maneuvers in multi-engine airplanes with an open nose baggage door, as this could throw loose objects out of the baggage compartment and into the propeller.

Front hinged wing locker doors in the aft part of the engine nacelle of multi-engine airplanes will likely trail open a few inches if they become unlatched. Near stall speed just prior to landing, an unlatched door may momentarily float to a full open position.

If a door comes open on takeoff and sufficient runway remains for a safe abort, the airplane should be stopped. If the decision is made to continue the takeoff, maintain required airspeed and return for landing as soon as practical.

### **INADVERTENT OPENING OF CABIN/EMERGENCY EXIT DOORS (UNPRESSURIZED)**

If a cabin or emergency exit door should inadvertently open during unpressurized flight, the primary concern should be directed toward maintaining control of the airplane. Then, if a determination is made to close the door in flight, establish a safe altitude, trim the airplane at a reduced airspeed, and attempt to close the door. To facilitate closing the door, slide the adjacent seat aft slightly to obtain a better grasp of the door handle. The door handle must be in the close position prior to pulling the door closed, followed by rotating the handle to the locked position. Under no circumstances should the pilot leave his/her seat, or unfasten the restraint system to secure a door.

If a cabin door reopens when latched closed, the flight should be terminated as soon as practical and repairs made.

### **INADVERTENT OPENING OF CABIN/EMERGENCY EXIT DOORS (PRESSURIZED)**

An inadvertent opening of a cabin/emergency exit door while the cabin is pressurized and the aircraft is above 12,500 feet, will require the use of supplemental oxygen or an emergency descent to an altitude below 12,500 feet. The pilot may attempt to close the door after ensuring that all occupants are using supplemental oxygen or the cabin altitude is below 10,000 feet. However, the primary concern should be maintaining control of the airplane. The flight should be terminated as soon as practical and the cause of the door opening determined before pressurized flight is continued. Under no circumstances should the pilot leave his/her seat, or unfasten the restraint system to secure a door.

## **AUTOPILOTS AND ELECTRIC TRIM SYSTEMS**

---

Because there are several different models of autopilots and electric trim systems installed in airplanes and different installations and switch positions are possible from airplane to airplane, it is essential that every pilot review the airplane operating handbook and/or the Garmin Integrated Flight Deck Cockpit Reference Guide (CRG) and Pilot's Guide (PG) if equipped with a Garmin Automatic Flight Control System (AFCS) for the specific autopilot and trim systems installed in their airplane. Each pilot prior to flight, must be fully aware of the proper procedures for operation, and particularly disengagement, for the system as installed.

In addition to ensuring compliance with the autopilot manufacturer's maintenance requirements, all pilots should thoroughly familiarize themselves with the operation, function and procedures described in the airplane operating handbook and/or the Garmin Integrated Flight Deck Cockpit Reference Guide (CRG) and Pilot's Guide. Ensure a full understanding of the methods of engagement and disengagement of the autopilot and trim systems. Compare the descriptions and procedures to the actual installation in the airplane to ensure it accurately describes the system installed. Test that all buttons, switches and circuit breakers function properly as described. If they do not function as described, have them repaired by a qualified service facility prior to using them in flight.

A preflight check as stated in all airplane operating handbooks for the autopilot and trim systems must be conducted before every flight. The preflight check assures not only that the systems and all the features are operating properly, but also that the pilot, before flight, is familiar with the proper means of engagement and disengagement of the autopilot and trim system.

Autopilot airplane operating handbooks caution against trying to override the autopilot system during flight without disengaging the autopilot because the autopilot will continue to trim the airplane and oppose the pilot's actions. This could result in a severely out of trim condition. This is a basic feature of all autopilots with electric trim follow-up.

Do not try to manually override the autopilot during flight.

### **WARNING**

**OVERRIDING AN ENGAGED AUTOPILOT SYSTEM DURING FLIGHT CAUSES THE TRIM SYSTEM TO TRIM THE AIRPLANE AND OPPOSE THE PILOT'S INPUT, RESULTING IN A SEVERELY OUT OF TRIM CONDITION.**

### **CAUTION**

IN CASE OF EMERGENCY, YOU CAN OVERPOWER THE AUTOPILOT TO CORRECT THE ATTITUDE, BUT THE AUTOPILOT AND ELECTRIC TRIM MUST THEN IMMEDIATELY BE DISENGAGED. DO NOT RE-ENGAGE THE AUTOPILOT OR USE THE ELECTRIC TRIM SYSTEM FOR THE REMAINDER OF THE FLIGHT OR ANY FUTURE FLIGHTS UNTIL THE SYSTEMS HAVE BEEN REPAIRED.

It is often difficult to distinguish an autopilot malfunction from an electric trim system malfunction. The safest course is to deactivate both. Do not re-engage either system until after you have safely landed. Then have the systems checked by a qualified service facility prior to further flight.

Depending upon the installation on your airplane, the following additional methods may be available to disengage the autopilot or electric trim in the event the autopilot or electric trim does not disengage utilizing the disengage methods specified in the Supplements and/or the Garmin CRG and PG.

### **CAUTION**

**TRANSIENT CONTROL FORCES MAY OCCUR WHEN THE AUTOPILOT IS DISENGAGED.**

1. Push the autopilot or autopilot trim disconnect switch on the yoke, if installed.
2. Operate the electric trim switch on the yoke, if installed.
3. Push the autopilot (AP) switch or button on the autopilot controller (this switch or button when pushed alternately engages and disengages the autopilot), if installed.
4. Turn off the autopilot master switch, if installed.
5. Pull the autopilot and trim circuit breaker(s) or turn off the autopilot switch breaker, if installed.
6. Push the go around (GA) switch or button on throttle grip or located on the instrument panel by the throttle control.

The above ways may or may not be available on your autopilot. It is essential that you the pilot, read your airplane's AFM supplement and/

or the Garmin CRG and PG, for your autopilot system and check each function and operation on your system.

The engagement of the autopilot must be done in accordance with the instructions and procedures contained in the airplane operating handbook and/or the Garmin CRG and PG.

Particular attention must be paid to the autopilot settings prior to engagement. If the autopilot is engaged when the airplane is out of trim, a large attitude change may occur.

### **CAUTION**

IT IS ESSENTIAL THAT THE PROCEDURES SET FORTH IN THE APPROVED AFM SUPPLEMENTS AND/OR THE GARMIN CRG AND PG, FOR YOUR SPECIFIC INSTALLATION BE FOLLOWED BEFORE ENGAGING THE AUTOPILOT.



## **MAINTENANCE**

---

Airplanes require inspection and maintenance on a regular basis as outlined in the operating handbook, service/maintenance manuals, other servicing publications, and in Federal Aviation Regulations. A good visual inspection is a continuing maintenance procedure and should be performed by anyone who is involved with an airplane. This includes pilots, line personnel, and the maintenance department. When worn or damaged parts are discovered, it is essential that the defective parts be repaired or replaced to assure all systems remain operational. The source of information for proper maintenance is the airplane Service/Maintenance Manual and Service Letters or Service Bulletins. Cessna's Service/Maintenance Manuals are occasionally revised. Maintenance personnel should follow the recommendations in the latest revision. The owner/operator must ensure that all unacceptable conditions are corrected and the airplane receives repetitive and required inspections.

### **UNAUTHORISED REPAIRS/MODIFICATIONS**

All repair facilities and personnel should follow established repair procedures. Cessna does not support modifications to Cessna airplanes, whether by Supplemental Type Certificate or otherwise, unless those modifications are approved by Cessna. Such modifications may void any and all warranties on the airplane, since Cessna may not know the full effects on the overall airplane. Cessna has not tested and approved all such modifications by other companies. Operating procedures and performance data specified in the operating handbook and maintenance procedures specified in the Service/Maintenance Manual may no longer be accurate for the modified airplane. Operating procedures, maintenance procedures and performance data that are effected by modifications not approved by Cessna should be obtained from the STC owner.

### **AIRWORTHINESS OF OLDER AIRPLANES**

For an airplane to remain airworthy and safe to operate, it should be operated in accordance with Cessna recommendations and cared for with sound inspection and maintenance practices.

An aging airplane needs more care and attention during maintenance processes and may require more frequent inspection of structural components for damage due to the effects of wear, deterioration, fatigue, environmental exposure, and accidental damage. Typical areas requiring more frequent inspection are:

1. Wing attach points and fuselage carry-through structure.
2. Wing spar capstrips, especially the lower ones.
3. Horizontal and vertical stabilizer attach points and spar structure.
4. Control surface structure and attach points.
5. Engine mounts, beams, and cowlings.
6. Landing gear structure and attach points.
7. Structural and flooring integrity of seat and equipment attachments.
8. Pressurized structures, especially around all doors, windows, windshields and other cutouts on pressurized airplanes.
9. Exhaust and cabin heater systems.

The final responsibility for airplane care rests with the owner/operator. All airplane owners/operators should use the following steps as a minimum guideline to ensure continued airworthiness of their airplanes:

1. Always follow recommended maintenance and inspection procedures.
2. Recognize that corrosion, overloading, or damage to structure can drastically shorten fatigue life.
3. Comply with all applicable Service Bulletins, Service Letters, and FAA Airworthiness Directives.
4. Use one of Cessna's Progressive Care Inspection and maintenance programs to get the maximum utilization of your airplane at a minimum cost and downtime.

## **CORROSION**

Corrosion can cause structural failure if left unchecked. The appearance of the corrosion varies with the metal. On aluminum and magnesium, it appears as surface pitting and etching, often combined with a grey or white powdery deposit. On copper and copper alloys the corrosion forms a greenish oxide and on steel, a reddish rust. When grey, white, green or red deposits are removed, each of the surfaces may appear etched and pitted, depending upon the length of exposure and severity of the attack. If the damage is not too deep, it may not significantly alter the strength of the metal. However, the pits may become sites for crack development. Some types of corrosion can travel beneath surface coatings and spread until the part fails.

Remove corrosion as soon as possible because it attacks and holds moisture in contact with the metal, which causes more corrosion to form. Every visible trace must be removed by some mechanical or chemical means. The surface must then be chemically treated to form a film which prevents oxygen or moisture from contacting the surface. Then, the protective surface (paint) must be restored.

There are several different types of corrosion and different ways of detecting it in its early stages. Uniform surface corrosion is the most common type of corrosion. When an area of unprotected metal is exposed to the atmosphere, there will be a uniform attack over the entire unprotected area. On a polished surface, this type of corrosion is first seen as a general dulling of the surface. If the corrosion is allowed to continue, the surface becomes rough and possibly frosted in appearance.

If surface corrosion is allowed to go untreated, it can progress into the next type of corrosion, called pitting. Pits form in localized areas and appear as white or grey powdery deposits. Metal is converted to salts, and when deposits are cleaned away, tiny pits or holes can be seen on the surface. If allowed to continue, pitting can progress completely through the metal in extreme cases.

Stress corrosion cracking is caused by the simultaneous effects of tensile stress and corrosion. Stress may be either internal or applied. Residual stress from the processes of heat treatment and forming, or sustained operating or static loads, can lead to stress corrosion.

Fretting corrosion is corrosion damage between close fitting parts which are allowed to rub together. It is the corrosive attack on one or both metals because of chafing under a load. The results of fretting are removal or pitting of the metal in the area of contact, galling, seizing, cracking or fatigue of the metal, loss of tolerance in accurately fitted parts, and loosening of bolted or clamped surfaces.

Corrosion is a universal problem that costs considerable amounts of time and money. It is essential that each airplane owner maintain his or her airplane based on the operating conditions, environment, and service experience. Corrosion can be effectively prevented and/or controlled if appropriate action is taken early.



## SEAT AND RESTRAINT SYSTEMS

---

### ADJUSTABLE SEAT ASSEMBLIES

Most Cessna manually-adjustable seats are suspended on two parallel, cabin floor mounted seat tracks by roller assemblies which allow the seat to move forward and rearward along the tracks. A series of holes are provided, usually in the forward end of either or both seat tracks, to accommodate a mechanical locking pin(s) which allows intermediate positioning and locking of the seat. To prevent the seat from disengaging from the seat tracks when reaching the ends, a mechanical seat stop is installed near both ends of the track(s).

Incidents of manually-adjustable seats slipping rearward or forward during acceleration or deceleration of the airplane have been reported. The investigations following these incidents have revealed discrepancies such as gouged lockpin holes, bent lockpins, excessive clearance between seat rollers and tracks, and missing seat stops, to name a few. Also, dust, dirt, and debris accumulations on seat tracks and in the intermediate adjustment holes have been found to contribute to the problem. A close check of each seat during daily preflight, improved cabin cleanliness, and replacement of parts when necessary will help prevent accidents involving seats. Visual checks of the airplane should always include the cabin interior.

When inspections are made, examination of the following items is recommended:

1. Check the seat assembly for structural integrity.
2. Inspect the roller assemblies for separation and wear.
3. Check the locking mechanism (actuating arm, linkage, locking pin or pins) for wear.
4. Check all seat track stops for security and proper installation.
5. Inspect seat tracks for condition and security, and the locking pin holes for wear, and dirt or debris accumulation.
6. Determine that the floor structure in the vicinity of the seat tracks is not cracked or distorted.
7. Ensure that the secondary seat stop addressed in mandatory Service Bulletin SEB89-32 is installed.

Damaged or worn parts are a potential hazard which should be immediately repaired or replaced. Cessna recommends repair and/or replacement of damaged components in accordance with the airplane's service or maintenance publications and Service Bulletins.

## **RESTRAINT SYSTEMS**

While performing the cabin portion of the daily preflight, it is recommended that pilots check each restraint system installed in the airplane. This should include a functional check of the restraint belt locking and releasing mechanism. If new passengers or students are to be carried, it is a good practice to insist that they operate the restraint system to become familiar with the procedures.

During inspections, maintenance personnel should check each restraint system installation for serviceability in accordance with current publications applicable to the airplane. Special attention should be given to restraint attachment points and to the nylon bushing on the belt at the point where the shoulder restraint harness attaches. Undetected cracks or broken connections could cause a serious situation to develop when it is least expected. The restraint system webbing should be inspected for degradation. Repair or replace the restraint system per Cessna instructions if damage is detected.

## **EXHAUST AND FUEL SYSTEMS**

---

### **THE ENGINE EXHAUST SYSTEM**

The primary function of an engine exhaust system is to route exhaust gases safely overboard. Other functions of the exhaust system may include use as the driving source for a turbocharger turbine and/or use as a heat source for carburetor and/or cabin heat requirements.

Heat and carbon monoxide are the unavoidable byproducts of all reciprocating engine operations. The temperatures within the exhaust system of an engine can exceed 1750°F. Consequently, if an exhaust leak should occur, heat damage can occur to the engine mounting structure, and accessories such as hoses, belts, wire bundles, etc. In some cases, the position of the leak could lead to engine stoppage and/or an engine compartment fire.

An exhaust system leak can also lead to carbon monoxide poisoning. This colorless, odorless, tasteless combustion byproduct is always present in exhaust fumes. For this reason, special seals are provided wherever cables, hoses, wire bundles, etc. pass through the engine firewall. For even greater protection from carbon monoxide, special window, door, and fuselage seals are installed. No leakage of exhaust into the cabin should be tolerated.

Exhaust systems should be checked for stains indicative of exhaust leaks at cylinder heads or cracks in the exhaust or tailpipe. The condition and security of the exhaust system in the area of the exhaust muffler shroud should be checked. Any cracks or leaks in this area could be a source for exhaust to enter the cabin.

### **ENGINE COMPARTMENT TEMPERATURES**

High engine compartment temperatures can degrade the operational efficiency of the engine and also accelerate the deterioration of engine components. Several conditions could cause or contribute to a higher than normal engine compartment temperature; however, improper operating techniques are found to be the most common cause. Avoid excessive operation of an engine on the ground. Prolonged ground operations should be done into the wind at rich mixture settings. If the cowling has been removed for maintenance, cooling airflow is poor and cylinder head temperature and oil temperature gages must be monitored during engine runups.

On virtually all air-cooled reciprocating engines, the engine and engine compartment are cooled by utilizing a pressure cooling baffle system with airflow as the cooling medium. The condition of these baffles and their seals is important.

Baffles should be secure and baffle seals should be positioned in a direction which would seal airflow around the engine baffles. Even a slight reduction in cooling efficiency can cause the engine to operate hotter than normal, thus increasing the potential for heat damaged components.

An inspection of the engine compartment, plus careful observation of the engine temperatures during normal flight, can be of great assistance in verifying the condition of the engine. If the pilot takes the time to record engine temperatures on a regular basis, trends within the engine can be detected early and corrected before a serious condition occurs.

## **HOSE AND WIRE HARNESS INTEGRITY**

All fuel, oil, and hydraulic components should be checked for condition, security and any evidence of leakage. All leaks should be repaired before starting the engine.

As airplanes and engines age, there is a need to re-emphasize the inspection or replacement requirements of engine hoses or lines that carry fuel, oil, or hydraulic fluid. For newer Cessnas, a replacement requirement for hoses in the engine compartment (except teflon lined) has been established at each 5 years or at engine overhaul, whichever occurs first. This is considered to include "shelf" life. All hose manufactured for airplane use is marked indicating the quarter-year in which they were manufactured. For instance, a listing of "4Q85" means the hose was manufactured in the fourth quarter of 1985. Maintenance personnel should not use hoses with a high "shelf" life age.

Like time, heat is always a detriment to hoses. The prudent pilot realizes during the daily preflight, that an engine hose might look good, but if it is wiggled, a telltale "crackle" may be heard. This means that the hose is brittle and should be replaced. Also if he slides his hand over the back side of the hose, he may find an abrasion or wear not visible from the front side.

Ignition leads/wire harnesses and spark plugs are also affected by excessive heating in the engine compartment. Overheating of the spark plug barrels, sometimes caused by damaged cylinder baffles or missing cooling air blast tubes, may seriously deteriorate the ignition leads. Any overheating of a spark plug by a defective baffle or exhaust gas leak at the exhaust pipe mounting flange can generate temperatures sufficient to cause pre-ignition and piston distress.

## **RETRACTABLE LANDING GEAR**

---

The adjustment and rigging of a retractable landing gear system should be done by trained maintenance personnel. Continued reliability of the landing gear system is only possible if it is properly maintained in the prescribed published manner. The rigging process must be performed exactly as published in the Cessna Service/Maintenance Manual and Service Bulletins. For complete emergency procedures concerning landing gear extension, refer to the airplane operating handbook.



## **PRESSURIZED AIRPLANES**

---

### **DOOR SECURITY**

The conventional and air-stair doors on pressurized airplanes have a series of pins, actuated by an overcenter locking handle, to maintain the door seal during the pressurization cycle. Some air-stair doors are sealed by pressurization air pressing against the cabin door windlace which covers the door gap. Door security can be verified by visually checking the locking indicator for the door handle safety lock, in the case of single-engine airplanes, and checking for correct locking indications provided in the door of multi-engine airplanes. It is recommended that pilots check the locking pins and door seals for cracks or damage during each preflight. Any damaged parts should be repaired prior to pressurized flight.

### **WINDOWS AND WINDSHIELDS**

The windows in pressurized airplanes are exposed to a fatigue cycle each time the airplane is pressurized. These cycles could lead to fatigue cracks in and around the windows. Windows should be inspected frequently for condition and serviceability. Windows or windshields having replacement life limits should be replaced prior to intervals defined in applicable service/maintenance manuals.

The windows and windshields on pressurized airplanes are particularly sensitive to crazing and scratches. Any crazing, cracks, or deep scratches cannot be tolerated for pressurized flight. Consult the airplane's operating manual when in doubt about the severity of the damage. Repairs should be completed prior to pressurized flight.

### **THE PRESSURE VESSEL**

There are significant structural differences between the fuselage of a non-pressurized airplane and one which is pressurized. The pressure vessel is the portion of the cabin area to be pressurized. Pressure differential is the difference between the atmospheric pressure at the altitude at which the airplane is flying and the pressure inside the cabin.

Any seam, joint, or hole where wire bundles or tubing pass through the pressure vessel must be sealed to maintain the selected pressurization. If any of these seals are deteriorated or missing, the normal cabin pressure differential may be impossible to attain. Maintenance personnel should inspect the pressure seals for serviceability. Any cracks in the skin of the pressure vessel could lead to sudden depressurization. Maintenance personnel should carefully inspect the pressure vessel for cracks, corrosion, and deterioration. Any damage should be corrected before pressurized flight.

If the airplane cabin is pressurized and it becomes necessary to use the heated alternate induction air on both engines, the pressurization controls must be selected OFF to preventing nacelle fumes from entering the cabin. The cabin should be depressurized and maximum ventilation provided. Therefore, if the flight altitude is above 10,000 feet, all occupants should use oxygen, if available, or descent should be initiated.

## POTENTIAL HAZARDS

---

### PROPELLERS

#### WARNING

**ALWAYS STAND CLEAR OF PROPELLER BLADE PATHS, ESPECIALLY WHEN MOVING THE PROPELLER. PARTICULAR CAUTION SHOULD BE PRACTICED AROUND WARM ENGINES.**

Review of propeller accidents indicates that most were preventable. A propeller under power, even at slow idling speed, has sufficient force to inflict fatal injuries. Pilots can be most effective in ensuring that passengers arrive and depart the vicinity of the airplane safely by stopping the engine(s) during loading and unloading.

Cessna airplanes are delivered with propellers using paint schemes to increase visibility of the blades. Owners should maintain the original paint scheme.

Pilots and Service personnel should develop the following safety habits:

1. Before moving a propeller or connecting an external power source to an airplane, be sure that the airplane is chocked, ignition switches are in the OFF position, throttle is closed, mixture is in IDLE CUT-OFF position, and all equipment and personnel are clear of the propeller. Failed diodes in airplane electrical systems have caused starters to engage when external power was applied regardless of the switch position.
2. When removing an external power source from an airplane, keep the equipment and yourself clear of the propeller.
3. Pilots should make certain that all personnel are clear of the propeller, prior to engine start.
4. Attach pull ropes to wheel chocks located close to a rotating propeller(s).
5. Before removing the wheel chocks, the pilot should hold brakes or apply the parking brake.
6. Be absolutely sure that all equipment and personnel are clear of the airplane before releasing the brakes.
7. Ground personnel should be given recurrent propeller safety training to keep them alert to the dangers of working around airplanes.

The pilot should carefully inspect the propeller during each preflight inspection. Some constant speed propellers manufactured by McCauley are subject to a requirement that they be filled with a red-dyed oil. This oil helps lubricate and prevent corrosion of internal

propeller parts and may assist in detection of cracks. If a crack is detected, the airplane should not be flown until the propeller is replaced.

## **AIR CONDITIONING FREON**

The refrigerant R-12 (Freon) is relatively safe to handle when using proper protective safety equipment. Since at sea level the boiling point of R-12 is -21.6°F, any contact with bare skin will immediately burn (freeze) the area. If R-12 should contact your eye, it will burn and can cause permanent blindness. Treat spills or splashes on your body by washing with clean, cool, water, and seek immediate medical attention. R-12, when heated to a high temperature such as with an open flame or spillage on a hot manifold, generates phosgene gas (a colorless gas with an unpleasant odor). This gas is a severe respiratory irritant and should be considered as a **deadly poison**.

## **USED ENGINE OIL**

Pilots and maintenance personnel who handle engine oil are advised to minimize skin contact with used oil, and promptly remove any used engine oil from their skin.

The following are some do's and don'ts concerning used engine oil:

1. Do follow work practices that minimize the amount of skin exposed, and the length of time used oil stays on the skin.
2. Do thoroughly wash used oil off skin as soon as possible.
3. Do wash oil-soaked clothing before wearing them again. Discard oil soaked shoes.
4. Do use gloves made from material that oil cannot penetrate.
5. Don't use kerosene, gasoline, thinners, or solvents to remove used engine oil. These products can cause serious toxic effects.
6. Don't put oily rags in pockets, or tuck them under a belt. This can cause continuous skin contact.
7. Don't pour used engine oil on the ground or down drains and sewers. This is a violation of Federal Law. The Environmental Protection Agency (EPA) encourages collection of used engine oil at collection point in compliance with appropriate state and local ordinances.

## **AVIATION FUEL ADDITIVE**

Ethylene glycol monomethyl ether (EGME), which is a primary ingredient in aviation fuel additives, is toxic. It creates a dangerous health hazard when breathed or absorbed into the skin. When inhaled, EGME is primarily a central nervous system depressant, and acute inhalation overexposure may cause kidney injury. The primary symptoms of inhalation overexposure include headache, drowsiness,

blurred vision, weakness, lack of coordination, tremor, unconsciousness, and even death. EGME is irritating to the eyes and skin and can be readily absorbed through the skin in toxic amounts. Symptoms of overexposure due to skin absorption are essentially the same as those outlined for inhalation.

When servicing fuel with an anti-ice additive containing EGME, follow the manufacturers instructions and use appropriate personal protective equipment. These items would include chemical safety goggles or shield, respirator with organic vapor cartridges, nonabsorbing neoprene rubber gloves and an apron and long-sleeved shirt as additional skin protection from spraying or splashing anti-ice additive.

In the event EGME contact is experienced, the following emergency and first aid procedures should be used.

1. If EGME is inhaled, remove person to fresh air. If breathing is difficult, administer oxygen. If the person is not breathing give artificial respiration. Always call a physician.
2. If eye or skin contact is experienced, flush with plenty of water (use soap and water for skin) for at least 15 minutes while removing contaminated clothing and shoes. Call a physician. Thoroughly wash contaminated clothing and shoes before reuse.
3. If ingested, drink large quantities of water and induce vomiting by placing a finger far back in throat. Contact a physician immediately. If vomiting cannot be induced, or if victim is unconscious or in convulsions, take immediately to a hospital or physician. Do not induce vomiting or give anything by mouth to an unconscious person.

Diethylene glycol monomethyl ether (DIEGME), a fuel anti-icing additive approved for use in some airplanes, is slightly toxic if swallowed and may cause eye redness, swelling and irritation. DIEGME also is combustible. Before using DIEGME, refer to all safety information on the container.

## **BIRDS, INSECTS, AND RODENTS**

Bird, insect, and mouse nests in airplanes are both hazardous and costly. They seem to find even the smallest opening on an airplane to make their nests. Evidence of nest building activities may include the following:

1. Any mud smears or droplets at pitot/static masts, fuel tank vents, crankcase breathers, stall warning vanes, cabin air vents, and any fluid drain holes are indications of mud dauber wasp activities.
2. Straw, string, or blades of grass extending from cowling openings, carburetor air intakes, blast tubes, or exhaust stacks are signs of birds at work.

3. Cotton batting, shreds of fabric, and/or paper at wheel wells and empennage openings are frequently indicators that rodents such as mice have been or may still be on board. They may gnaw any material in the airplane including wire bundles and rubber or plastic tubing.

If nests or building materials are found on the airplane, they must be removed before flight. It is strongly recommended that a qualified mechanic thoroughly inspect components such as pitot/static systems for remains of any nesting material after its removal and before flight to ensure complete removal. Even small amounts of foreign material can result in significant problems in flight.

Some precautions can be taken to prevent problems. Always use the pitot tube cover and any other external covers when the airplane is being stored. If the airplane is hangared, make sure the hangar is kept clean and neat to prevent insects and mice from lodging in the hangar in the first place. If need be, set traps for rodents and/or spray the area for insects. Models of predators that appear life-like such as owls or snakes may also be effective at preventing some birds from lodging in a hangar.

Removal of the nest of an insect, bird, or rodent does not prevent reconstruction elsewhere on the airplane or even in the same location again. Some creatures are not easily discouraged and may return to cause problems within a very short time period. Regardless of precautions used to prevent such problems, the pilot should be alert to the evidence of small animal activities during every preflight inspection.

## **FIRE EXTINGUISHER AGENTS**

Halon, Bromochloromethane (CB), Carbon Dioxide (CO<sub>2</sub>), and dry chemical extinguishing agents are four of the most common types of fire extinguishing agents found in and around airplanes. Prolonged exposure (5 minutes or more) to any of these agents in a confined area could cause serious injury or even death. Pilots and ground personnel should become familiar with the precautions associated with each particular agent. Adequate respiratory and eye protection from excessive exposure, including the use of oxygen when available, should be sought as soon as the primary fire emergency will permit.

The discharge of large amounts of carbon dioxide to extinguish a fire may create hazards to personnel such as oxygen deficiency and reduced visibility. The dilution of the oxygen in the air, by the carbon dioxide concentrations that will extinguish a fire, may create an atmosphere that will not sustain life. Personnel rendered unconscious under these conditions can usually be revived without any permanent ill effects when promptly removed from the adverse condition.

The discharge of large amounts of dry chemical agents may create hazards to personnel such as reduced visibility and temporary

breathing difficulty. Where there is a possibility that personnel may be exposed to dry chemical agents, suitable safeguards should be provided to ensure prompt evacuation.

## **OXYGEN**

Before servicing any airplane with oxygen, consult the specific airplane service/maintenance manual to determine the proper type of servicing equipment to be used. Airplanes should not be serviced with oxygen during refueling, defueling, or other maintenance work which could provide fuel and a source of ignition. Also, oxygen servicing of an airplane should be accomplished outside, not in hangars.

Oxygen is a very reactive material, combining with most of the chemical elements. The union of oxygen with another substance is known as oxidation. Extremely rapid or spontaneous oxidation is known as combustion. While oxygen is non-combustible in itself, it strongly and rapidly accelerates the combustion of all flammable materials; some to an explosive degree.

The following are some do's and don'ts when handling or using oxygen:

1. Do check that only "aviators breathing oxygen" is going into the airplane system.
2. Don't confuse aviators breathing oxygen with "hospital/medical" oxygen. (The latter is pure enough for breathing, but the moisture content is usually higher which could freeze and plug the lines and valves of an airplane oxygen system).
3. Do reject any oxygen that has an abnormal odor (good oxygen is odorless).
4. Do follow the published applicable instructions regarding charging, purging, and maintenance of airplane oxygen systems.
5. Don't use oil or grease (including certain lipsticks and lip balms) around oxygen systems.
6. Don't expose oxygen containers to high temperatures.

## **COMPRESSED AIR**

Compressed air is a mechanic's tool as versatile as electricity, and can be as deadly. The use of compressed air to blow dust or dirt from parts of the body or clothing is a dangerous practice. As little as 12 psi can dislocate an eyeball. Air can enter the navel through a layer of clothing and inflate and rupture the intestines. Compressed air has been known to strike a small wound on a person's hand and inflate the arm.

Never look into or point any compressed air apparatus toward any part of the body. Always wear prescribed personal protective equipment. Also, continuously check the condition of air tools and air hoses to

make sure they do not show signs of damage or looseness. A loose hose carrying pressure is like a bullwhip and can cause serious injury to personnel and/or cause damage to surrounding equipment. If a situation such as this should occur, do not attempt to catch the hose end; shut off the air source first.

## **STATIC ELECTRICITY**

Static electricity, by definition, is a negative or positive charge of electricity that an object accumulates, and creates a spark when the object comes near another object. Static electricity may accumulate on an airplane during flight or while it is on the ground, as long as air is flowing over its surfaces. Unless static electricity is carried away by ground wires, an explosion may be caused during any fueling operations.

Grounding an airplane is a good safety precaution because static electricity cannot be seen until it's too late. To properly ground an airplane, attach one end of a static ground wire to an unpainted point on the airplane and the other end to an approved grounding stake. Attaching the ground wire to the airplane first will ensure that any spark of static electricity will occur at the grounding stake and not at the airplane. Do not attach a ground wire to any antenna. Antennas are poor grounding attachment points because they are insulated from the airplane structure.

On some airplanes, wick-type static dischargers are installed to improve radio communications during flight through dust or various forms of precipitation (rain, snow or ice crystals). Under these conditions, the build-up and discharge of static electricity from the trailing edges of wings, rudder, elevator, and propeller tips can result in loss of usable radio signals on all communications and navigation radio equipment. Usually the ADF is first to be affected and VHF communication equipment is the last to be affected. Installation of static dischargers reduces interference from precipitation static, but it is possible to encounter severe precipitation static conditions which might cause the loss of radio signals, even with static dischargers installed.

Static dischargers lose their effectiveness with age, and therefore should be checked at every scheduled inspection by a qualified technician. If testing equipment is not available, it is recommended that the wicks be replaced every two years, especially if the airplane is operated frequently in IFR conditions.

## ELT BATTERY AND GAS SPRING/DAMPER DISPOSAL

To prevent bodily injury, do not compact (compress) or incinerate an ELT battery-pack or gas spring/damper. The ELT battery pack should be discarded in accordance with local EPA standards.

A gas spring or gas damper contains an inert gas and oil under pressure, and reacts much like an aerosol can when compressed or heated; it may explode. Therefore, all unserviceable gas springs or dampers should be depressurized, using the maintenance manual instructions.

## HEARING LOSS

Hearing loss due to overexposure to loud noise levels is a real possibility while working near operating airplane engines. Continuous exposure to excessive noise diminishes hearing acuity, with high frequency response failing first. If the overexposure continues, the middle frequencies, most important in conversation, are also lost. Earmuffs, some headset types, and earplugs are very useful to avoid hearing loss. By far, the earplug has proven to be the best protection overall. Limits have been established which relate sound level (dB) to exposure time. These limits are based on daily exposures for long intervals.

Sound Level (dB)	115	110	105	100
Maximum Time (min.)	15	30	60	120

## WEATHER RADAR EXPOSURE

The dangers of exposure to airborne weather radar operated on the ground include the possibility of damage to low tolerance parts of the human body and ignition of combustible materials by radiated energy. Low tolerance parts of the body include the eyes and testes. Airborne weather radar should be operated on the ground only by qualified personnel. The radar should not be operated while the airplane is in a hangar or other enclosure unless the radar transmitter is disconnected, or the energy is directed toward an absorption shield which dissipates the radio frequency (RF) energy.

Personnel should never stand near or directly in front of a radar antenna which is transmitting. When the antenna is transmitting and scanning, personnel should not be allowed within 15 feet of the area being scanned by the antenna.

Personnel should not be allowed at the end of an open waveguide (hollow duct work through which electromagnetic waves are conducted to and from the antenna) unless the radar is off and will remain off. Radar should not be operated with an open waveguide unless a "dummy load" is connected to the portion which is connected to the transmitter. Personnel should not look into a waveguide, or the open end of a coaxial connector or line connected to a radar transmitter.

Weather radar installed on any airplane should not be operated while that airplane, or an adjacent airplane is being refueled or defueled.

# NOTES

# NOTES

# NOTES

# NOTES

